

SIPHON CLEANING GUN

Model 939

FOR USE WITH SOLVENTS OR DETERGENT SOLUTIONS
 COMPATIBLE WITH VINYL, ALUMINUM AND CARBON STEEL
 MAXIMUM AIR PRESSURE - 200 PSI

Series "C"

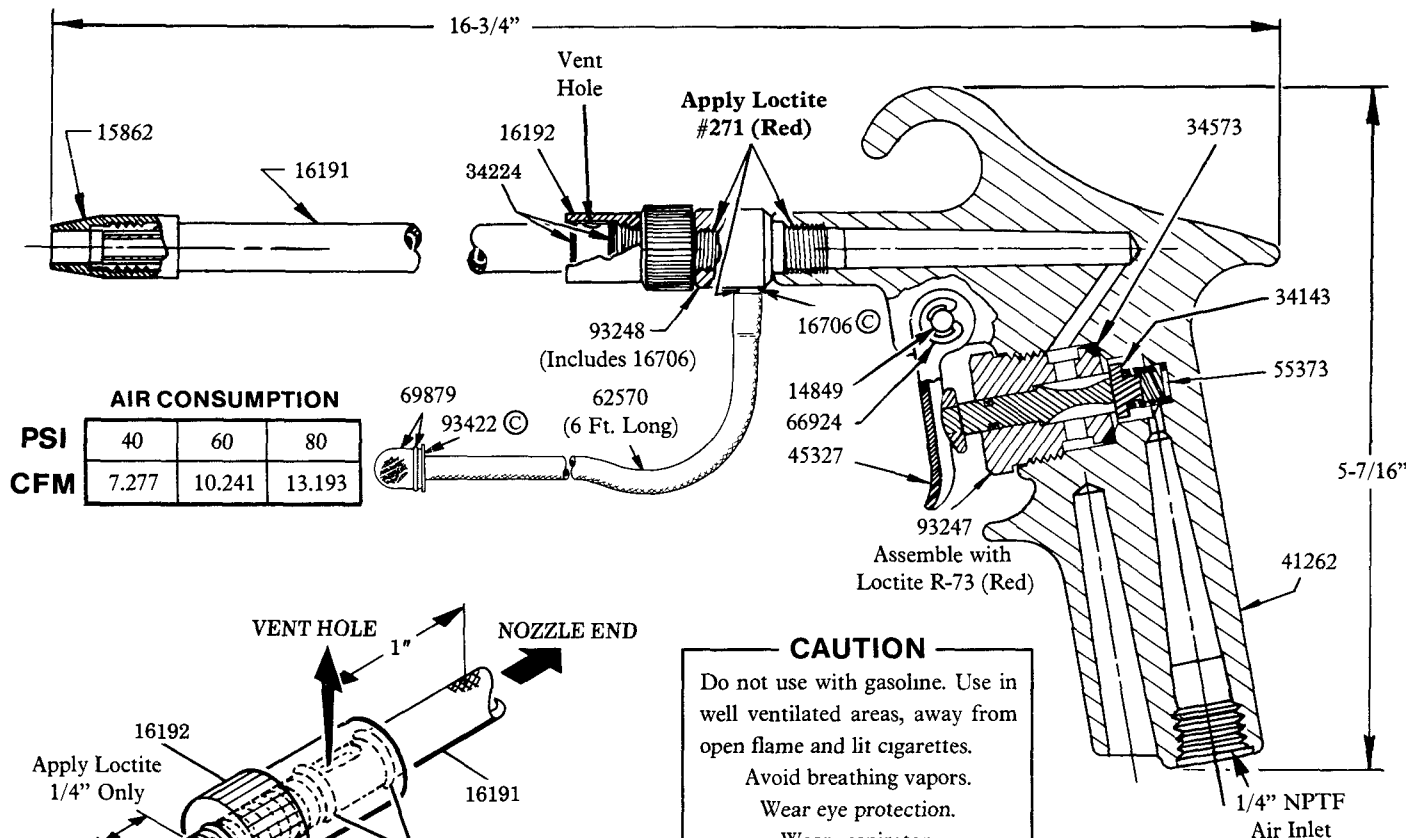

| | | AIR CONSUMPTION | | |
|-----|-------|-----------------|--------|--|
| PSI | 40 | 60 | 80 | |
| CFM | 7.277 | 10.241 | 13.193 | |

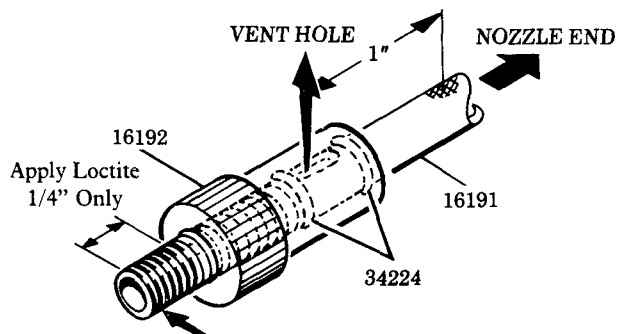

CAUTION
 Do not use with gasoline. Use in well ventilated areas, away from open flame and lit cigarettes. Avoid breathing vapors. Wear eye protection. Wear respirator.

© Indicates Change

SERVICE PARTS

| PART | QUAN. | DESCRIPTION |
|-------|-------|------------------------|
| 14849 | 1 | Pin |
| 15862 | 1 | Nozzle |
| 16191 | 1 | Tube |
| 16192 | 1 | Sleeve nut |
| 16706 | 1 | Tube adapter |
| 34143 | 1 | Valve disc |
| 34224 | 2 | O-ring |
| 34573 | 1 | O-ring |
| 41262 | 1 | Air gun body |
| 45327 | 1 | Trigger |
| 55373 | 1 | Check spring |
| 62570 | 1 | Vinyl tubing |
| 66924 | 1 | Retaining ring |
| 69879 | 1 | Strainer assembly |
| 93247 | 1 | Actuator assembly |
| 93248 | 1 | Body & tube assembly |
| 93422 | 1 | Strainer tube assembly |

ASSEMBLY

Before beginning assembly, place a mark with a suitable marker at least 1 inch from vent hole on 16191 Tube (as illustrated) to assure proper placement of vent hole.

Screw 16192 Sleeve Nut as far as possible onto 16191 Tube. Apply Loctite #271 (Red) to first 1/4" of 16191 threads; screw into 93248 Body & Tube Assembly as far as possible, then back out until vent hole mark on tube and 16706 Tube Adapter are 180° apart. Excess loctite must be wiped from threads.

IMPORTANT: 16192 Sleeve Nut must move freely on 16191 Tube.

Apply Loctite to 93248 Body & Tube Assembly and screw into 41262 Air Gun Body, then back out until tubing connection is pointing downward, then check to be sure vent hole is pointing up. Screw 15862 Nozzle onto tube.

OPERATION

Submerge end of 62570 Tubing with strainer into cleaning solution. Adjust air pressure as desired. Regulate flow by rotating 16192 Sleeve Nut.

A DIVISION OF
LINCOLN McNEIL
 CORPORATION
 One Lincoln Way, St Louis, MO 63120 (314) 679-4200

SECTION - **F53**
 PAGE - **6C**