

FOR BEARINGS WITH MAX. 3-1/4" O.D. X 5/8" TO 1-1/2" I.D. **MODEL 222**

NOTE: Replace 68645 Pipe Plug with 91108 Filler Nipple (must be ordered separately) to fill container with filler pump. See reverse page for instructions.

237138 ©

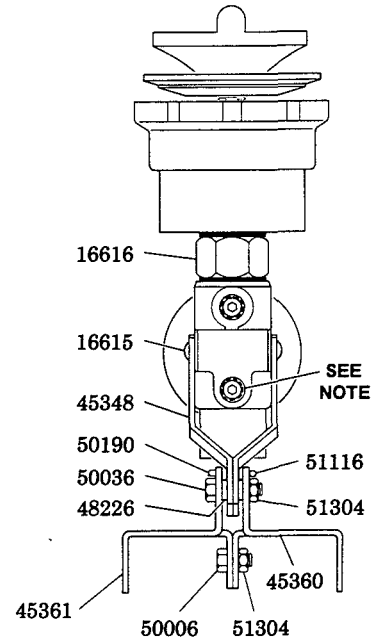
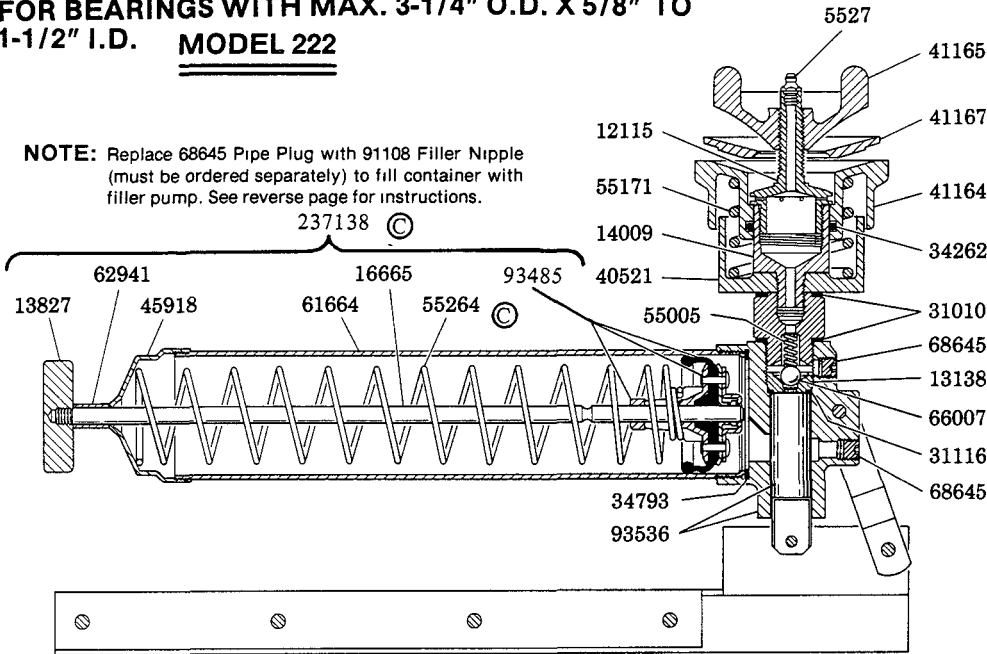

MODEL 816

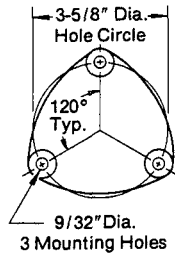
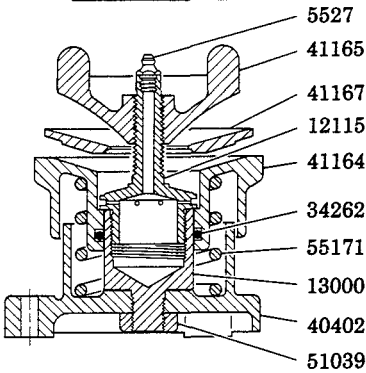

Model 816

MOUNTING HOLE DIMENSIONS

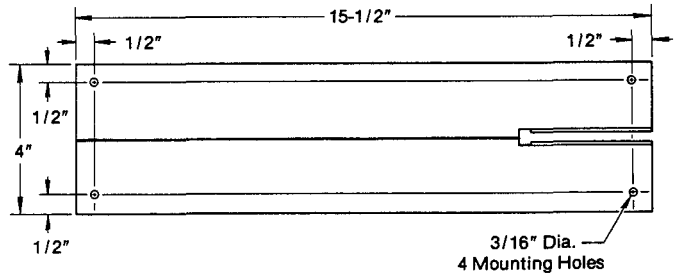

Model 222

SERVICE PARTS

© Indicates Change

PART	QUAN.	DESCRIPTION	PART	QUAN.	DESCRIPTION	PART	QUAN.	DESCRIPTION
5527	1	Fitting	40402	1	Body casting	51039	1	Jam nut
12115	1	Locating stud	40521	1	Body casting	51116	1	Nut
13000	1	Sleeve	41164	1	Head casting	51304	5	Nut
13138	1	Check seat	41165	1	Wing knob	55005	1	Spring
13827	1	Follower handle	41167	1	Adapter ring	55171	1	Spring
14009	1	Sleeve	45348	2	Toggle	55264	1	Spring
16615	1	Toggle pin	45360	1	Mounting base (left)	61664	1	Container tube
16616	1	Adapter	45361	1	Mounting base (right)	62941	1	Spacer
16665	1	Follower rod	45918	1	Tube cap	66007	1	Ball
31010	2	Gasket	48226	2	Spacer	68645	2	Pipe plug
31116	1	Gasket	50006	4	Screw	93485	1	Follower
34262	1	O-ring	50036	1	Screw	93536	1	Body and plunger
34793	1	Packing	50190	1	Screw	237138	1	Tube Assy.

ROLLER BEARINGS

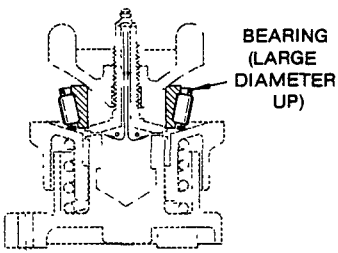

BEARING
(LARGE
DIAMETER
UP)

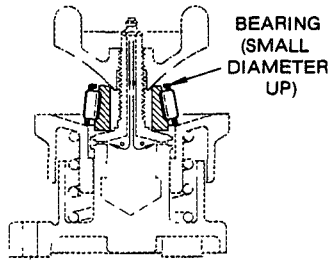

BEARING
(SMALL
DIAMETER
UP)

Position of bearings having inside diameters larger than 7/8" and up to 1-1/2" diameter.

Position of bearings having inside diameters larger than 5/8" and up to 7/8" diameter.

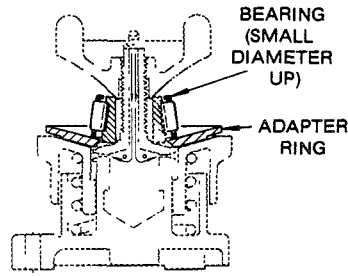

BEARING
(SMALL
DIAMETER
UP)

ADAPTER
RING

Use 41167 Adapter Ring with 5/8" inside diameter bearing.

BALL BEARINGS

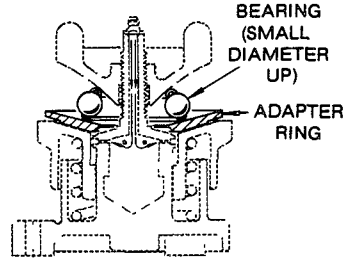

BEARING
(SMALL
DIAMETER
UP)

ADAPTER
RING

Use 41167 Adapter Ring as shown with ball type bearing.

OPERATION

Remove 41165 Wing Knob and place bearing over 12115 Locating Stud in the proper position (as shown in above illustrations). Replace wing knob and turn until 41164 Head Casting is completely depressed. Bearing should be held securely against head casting.

Model 222: Using the 61664 Container Tube as a lever, pump the wheel bearing packer to flush and pack the bearing. Refer to instructions below for filling container tube.

Model 816: Bearings can be flushed and packed by using either a power operated lubrigun or hand operated lever gun, high or low pressure. Contact fitting with hydraulic coupler. Force lubricant through until it is visible at top of bearing.

Multi-purpose grease used for chassis lubrication can also be used for wheel bearing packing.

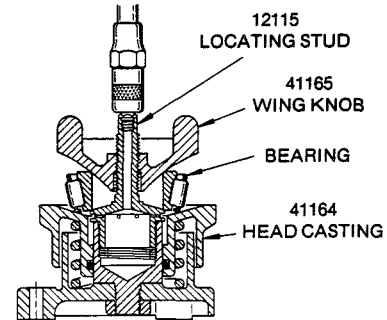

12115
LOCATING STUD

41165
WING KNOB

BEARING

41164
HEAD CASTING

TO INSTALL A LUBRICANT CARTRIDGE

- 1) Remove container tube from body and plunger assembly.
- 2) To remove an empty cartridge, pull back on the follower handle until the follower rod is fully extended. Then, carefully release the follower handle to eject the empty cartridge from the container tube. Pull back on the follower handle. When the follower rod is fully extended, pull it sideways to latch the rod groove into the keyhole slot in the container cap.

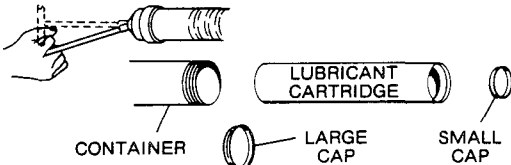

- 3) Remove the caps from both ends of the cartridge and insert the large open end of the cartridge into the container tube.
- 4) Loosely assemble the container tube to the body and plunger assembly. Extend the container tube away from the mounting base and disengage the follower rod from the container cap.

Engage the follower rod with the follower by rotating the follower handle. Exert force on the follower handle until lubricant oozes from the tube and body interface. Tighten container tube into the body and plunger assembly.

- 5) Disengage the follower rod from the follower by rotating the follower handle. Push the follower rod into the container.

TO EXPEL AIR POCKETS

- 1) Unscrew the container tube 1-1/2 turns from the body and plunger assembly.
- 2) Withdraw the follower rod from the container cap and engage it with the follower by rotating the follower handle. Exert force on the follower handle until lubricant oozes from the tube and body interface.
- 3) Tighten container tube into the body and plunger assembly. Disengage the follower rod from the follower by rotating the follower handle. Push the follower rod into the container.

IMPORTANT: Air pockets in the cartridge lubricant will cause the wheel bearing packer to lose its prime.

TO CONVERT FROM CARTRIDGE LUBRICANT TO BULK FILL

- 1) Unscrew the container cap from the container tube. Pull on the follower handle to extract the follower and spring from the container tube.
- 2) Grasp follower between thumb and forefinger and flip the follower lip from the rear to the front side.
- 3) Reassemble follower into container tube and position with the follower handle so that the container cap can be tightened onto the container tube.

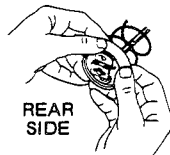

REAR
SIDE

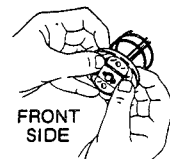

FRONT
SIDE

deeper into the lubricant to prevent air pockets from being pulled into the container tube.

- 4) When the follower rod is fully extended, pull it sideways to latch the rod groove into the keyhole slot in the container cap.
- 5) Loosely assemble the filled container tube to the body and plunger assembly. Release the follower rod from the container cap and disengage the follower rod from the follower by rotating the follower handle. Push the follower rod into the container. Slowly unscrew the container tube from the body and plunger assembly until lubricant oozes from the interface. Tighten container tube into the body and plunger assembly.

TO FILL CONTAINER TUBE WITH A FILLER PUMP

Replace 68645 Pipe Plug with 91108 Filler Nipple (must be ordered separately). Engage the follower rod with the follower by rotating the follower handle. Insert the filler nipple into the filler pump socket and extend the container tube away from the mounting base. Operate the filler pump to fill the container. When the follower rod groove is exposed, the container is filled (follower rod will be extended approximately 8 inches). Disengage the follower rod from the follower by rotating the follower handle. Push the follower rod into the container.

TO FILL CONTAINER TUBE FROM BULK LUBRICANT CONTAINER

- 1) Remove container tube from body and plunger assembly.
- 2) Pack lubricant into cavity of body and plunger assembly.
- 3) Insert the open end of the container tube into lubricant. Slowly pull the follower handle back while pushing the container tube