

- 247782 - BASIC 1/4" CLAMP
- 247783 - BASIC 1/2" CLAMP
- 247792 - BASIC 1/4" WALL BRACKET
- 247793 - BASIC 1/2" WALL BRACKET

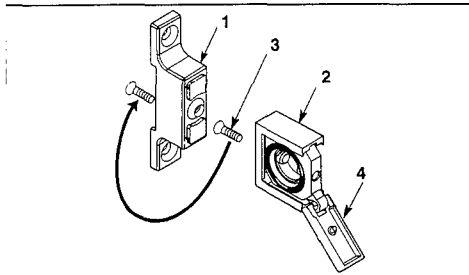

Figure 1. Basic 1/4" Clamp and Wall Bracket

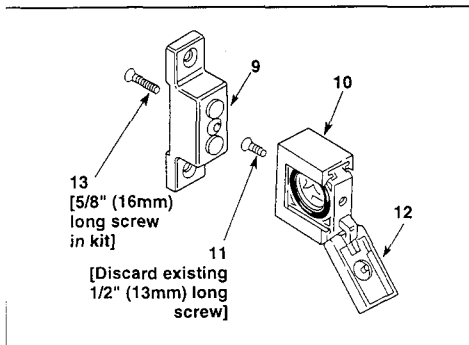

Figure 2. Basic 1/2" Clamp and Wall Bracket

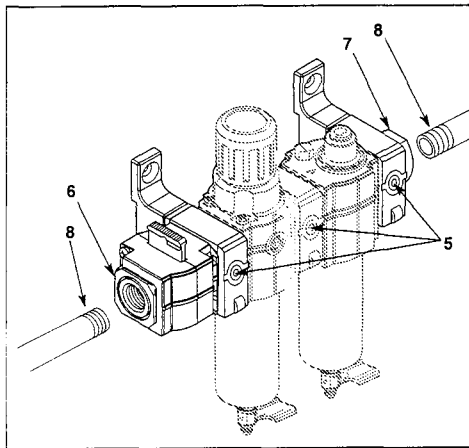
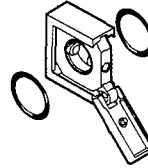

Figure 3. FRL Installation

BASIC 1/4" CLAMP IDENTIFICATION AND SPECIFICATIONS

The Basic 1/4" clamp does not have o-ring grooves that retain the face-sealing o-rings. O-rings are retained by grooves in the Basic 1/4" FRL Units.



Technical Data

Fluid: Compressed air
Maximum pressure: 250 psig (17.2 bar)
Maximum temperature: 150°F (65°C)
Body: Zinc
Elastomers: Nitrile

BASIC 1/2" CLAMP IDENTIFICATION AND SPECIFICATIONS

The Basic 1/2" clamp has o-ring grooves that retain the face-sealing o-rings.

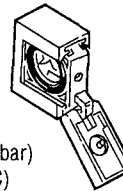

Technical Data

Fluid: Compressed air
Maximum pressure: 250 psig (17.2 bar)
Maximum temperature: 175°F (79°C)
Body: Zinc
Elastomers: Nitrile

SERVICE KIT - Contains 2 o-rings

Basic 1/4" Clamp	247885
Basic 1/2" Clamp	247887

TOOLS REQUIRED

Basic 1/4" Clamp: 3mm hex or T15 Torx wrench for screw (3, 5).
Basic 1/2" Clamp: 5/32" (4mm) hex or a T25 Torx wrench for screw (5, 11, 13).

BASIC 1/4" SERIES OPTIONAL WALL BRACKET (FIG. 1)

If optional wall bracket (1) is not assembled to clamp (2):

1. Remove screw (3) from clamp.
2. Attach wall bracket to clamp using screw (3).
Tighten screw (3) as shown in the Torque Table.

BASIC 1/2" SERIES OPTIONAL WALL BRACKET (FIG. 2)

If optional wall bracket (9) is not assembled to clamp (10):

1. Remove and discard screw (11).
2. Attach wall bracket to clamp using screw (13).
Tighten screw (13) as shown in the Torque Table.

ATTACH UNITS TO CLAMP

1. Loosen captive screw (5), then open clamp (4 or 12).
2. **Basic 1/4" Clamp** - Make sure o-rings are securely in place in the o-ring grooves in the units.
Basic 1/2" Clamp - Make sure o-rings are securely in place in the o-ring grooves in the clamp.
3. Engage the port flanges on the units with the V-grooves in the clamp, then slide the units into clamp.

NOTE

Clamps can be installed in any of four orientations over the port flanges on the FRL Units.

4. Close the clamp and tighten the captive screw (5) as shown in the Torque Table. **Do not tighten or adjust clamps when clamp is under pressure.**

INSTALL IN AIR LINE

1. Connect system pipe to proper ports using pipe thread sealant on male threads only. Do not allow sealant to enter interior of unit.
2. Hold unit with a pipe wrench on the body, the port flange (6), or the pipe adapter (7), then tighten pipe (8) into ports.

CAUTION

Failure to hold unit in place with a wrench when turning pipe (8) into ports may result in damage to the clamp and the clamp wall bracket.

REMOVE FRL UNITS FROM CLAMP

1. Shut off inlet pressure. Reduce pressure in inlet and outlet lines to zero.
2. Loosen captive screw (5), open clamp, and remove unit.

TORQUE TABLE

Clamp	Item	Torque
		Inch-Pounds(N-m)
Basic 1/4"	3, 5 (Screw)	15 to 25 (1.7 to 2.8)
Basic 1/2"	5, 13 (Screw)	30 (3.4)

WARNING

These products are intended for use in industrial compressed air systems only. Do not use these products where pressures and temperatures can exceed those listed under **Technical Data**.

Do not loosen or tighten captive screw (5) when the clamp is pressurized. If screw is loosened when clamp is pressurized, an audible air leak warns of air pressure. If screw is over-torqued when the clamp is pressurized, the threads can be damaged and system pressure may rapidly open the clamp (4 and 12).

Do not use these products with fluids other than air, for nonindustrial applications, or for life-support systems.