

602138 - 1/2" PORTS
602142 - 3/4" PORTS

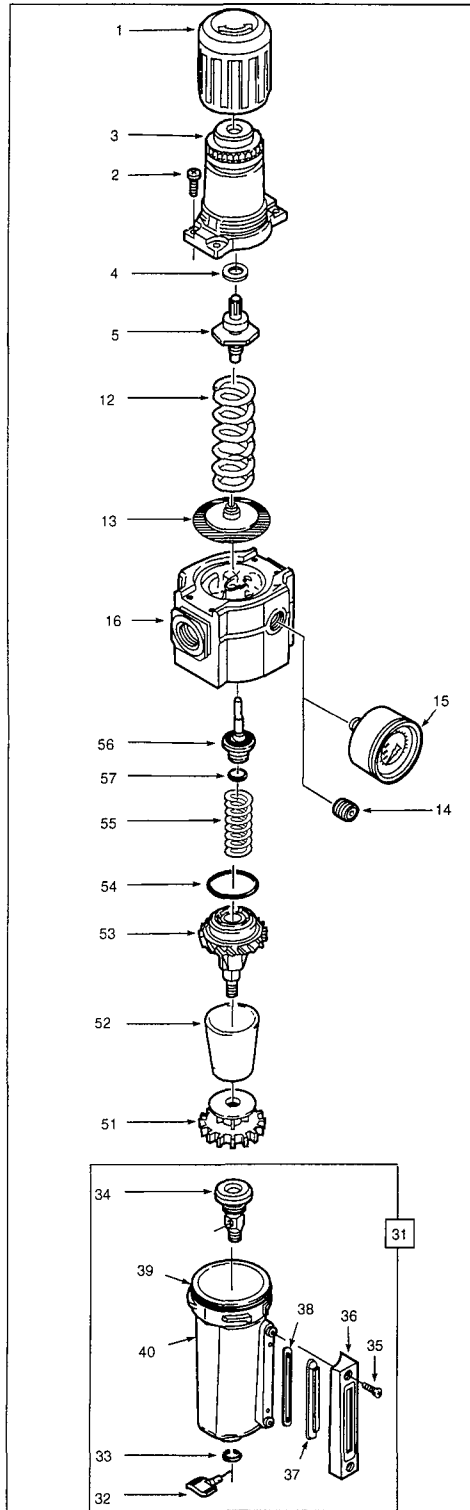

TECHNICAL DATA

Fluid: Compressed air
Maximum Pressure: 250 psig (17 bar)
Operating Temperature: 0° to +175°F (-20° to +79°C)*

* Air supply must be dry enough to avoid ice formation at temperatures below +35°F (+2°C)

Main ports: 1/2" PTF or 3/4" PTF
Gauge ports: 1/4" PTF
Outlet pressure adjustment range: 5 to 150 psig (0.3 to 10 bar)**

**Outlet pressure can be adjusted to pressures in excess of, and less than, those specified Do not use these units to control pressures outside of the specified ranges

Filter element rating: 40µm

Materials:

- Body: Aluminum
- Bonnet: Aluminum
- Valve: Brass
- Bowl: Aluminum
- Liquid level indicator lens: Transparent nylon
- Element: Sintered polypropylene plastic
- Elastomers: Neoprene and Nitrile

REPLACEMENT ITEMS AND ACCESSORIES

Service Kit (13, 39, 54, 55, 56, 57)	247883
Liquid level lens kit (35, 37, 38, 39)	247876
Filter element, 40µm (52)	247874
Manual drain (32, 33, 34)	247893
Tamper resistant cover	247778

PANEL MOUNTING DIMENSIONS

Panel mounting hole diameter: 2.06" (52 mm)
Panel thickness: 0.06" to 0.25" (2 to 6 mm)

INSTALLATION

1. Install unit vertically in air line -
 - upstream of lubricators and cycling valves,
 - with air flow in direction of arrow on body,
 - as close as possible to the device being serviced.
2. Connect piping to proper ports using pipe thread sealant on male threads only. Do not allow sealant to enter interior of unit
3. Turn bowl fully clockwise into body before pressurizing.
4. Install a pressure gauge or plug the gauge ports. Gauge ports can also be used as additional outlets for regulated air.
5. Manual drain is ported 7/16-24 UNS male for 1/4" tube nut and ferrule.

ADJUSTMENT

1. Turn adjustment clockwise to increase pressure setting. Turn adjustment counterclockwise to decrease pressure setting.
2. Always approach the desired pressure from a lower pressure. When reducing from a higher to a lower setting, first reduce to some pressure less than that desired, then bring up to the desired pressure.
3. Push knob down to lock pressure setting. Pull knob up to release. Install tamper resistant cover (see **Replacement Items and Accessories**) to make setting tamper resistant.

SERVICING

1. Open manual drain to expel accumulated liquids. Keep liquids below baffle (51)
2. Clean or replace filter element (52) when dirty

DISASSEMBLY

1. Shut off inlet pressure. Reduce pressure in inlet and outlet lines to zero. Turn adjustment (1) fully counterclockwise.
2. Remove bowl - push into body and turn counterclockwise.
3. Disassemble in general accordance with the item numbers on exploded view. Disassemble and replace drain (32, 33, 34) only if it malfunctions

CLEANING

1. Clean lens (37) with warm water only. Clean other parts with warm water and soap
2. Rinse and dry parts. Blow out internal passages in body with clean, dry compressed air. Blow air through filter element (52) from inside to outside to remove surface contaminants
3. Inspect parts. Replace parts found to be damaged.

ASSEMBLY

1. Lubricate o-rings, valve stem (56), outer circumference and both sides of the thrust washer (4), and stem of drain valve (32) with o-ring grease.
2. Assemble the unit as shown on the exploded view. Turn bowl (40) fully clockwise into body
3. Torque Table

	Inch-Pounds (Nm)
2 (screw)	25 to 35 (2.8 to 3.9)
35 (screw)	13 to 16 (1.5 to 1.8)
53 (center-post)	18 to 24 (2.0 to 2.7)

CAUTION

Water vapor will pass through these units and could condense into liquid form downstream as air temperature drops. Install an air dryer if water condensation could have a detrimental effect on the application.

WARNING

These products are intended for use in industrial compressed air systems only. Do not use these products where pressures and temperatures can exceed those listed under **Technical Data**.

If outlet pressure in excess of the filter/regulator pressure setting could cause downstream equipment to rupture or malfunction, install a pressure relief device downstream of the filter/regulator. The relief pressure and flow capacity of the relief device must satisfy system requirements.

The accuracy of the indication of pressure gauges can change, both during shipment (despite care in packaging) and during the service life. If a pressure gauge is to be used with these products and if inaccurate indications may be hazardous to personnel or property, the gauge should be calibrated before initial installation and at regular intervals during use.

Do not use these products with fluids other than air, for non industrial applications, or for life-support systems.