

### OPERATING PRESSURES

PRIMARY— 300 PSI FOR ALL MODELS

SECONDARY— 0-125 PSI for Models 600002, 600003, 600005, 600007, 600009, 600013, 600017

SECONDARY— 0-250 PSI for Models 600004, 600006, 600008, 600012, 600016

MAXIMUM TEMPERATURE — 120° F for all Models

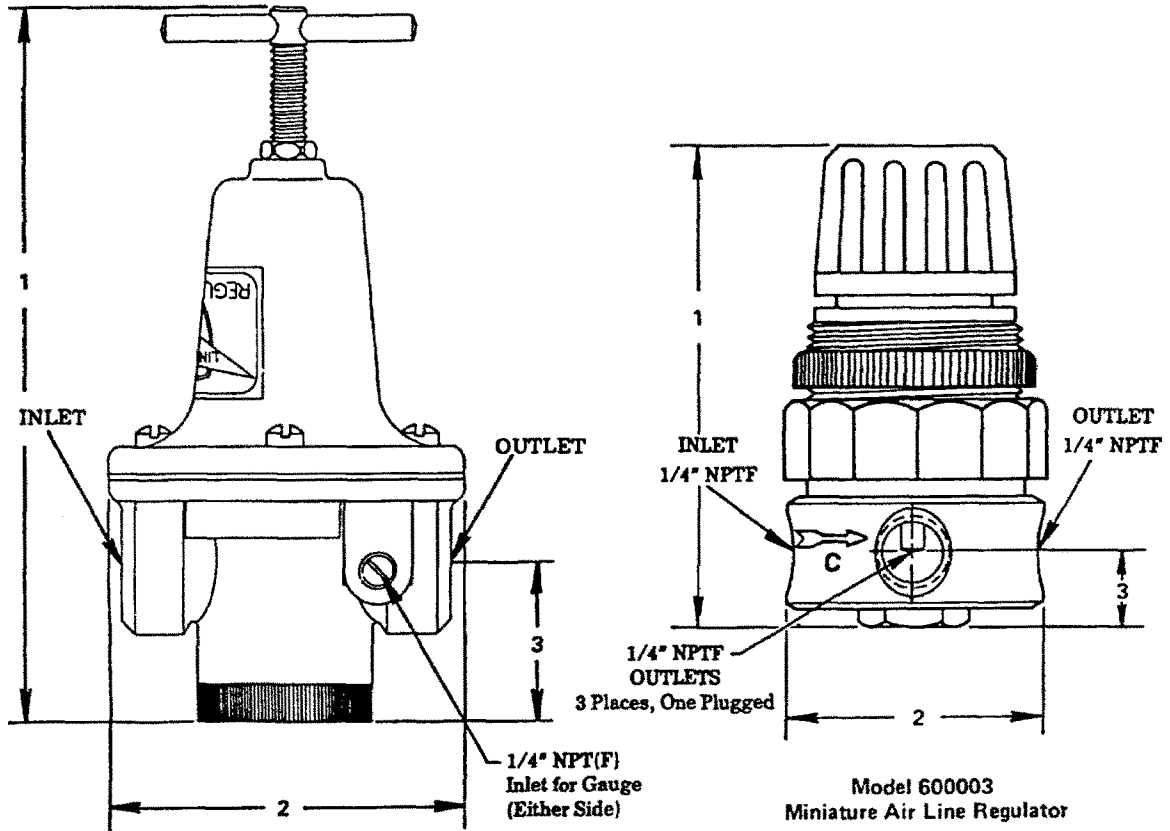

### DIMENSIONS

Model	Thread Size	1	2	3
600002	1/4" 1.3.7.	6-1/8"	3" D.I.D.	1-3/8"
600003	1/4" 1.3.7.)	2-13/16"	1-9/16" D.I.D.	1/2"
600004	1/4" 1.3.7.	6"	3" D.I.D.	1-3/8"
600005	1/4" 1.3.7.	6"	3" D.I.D.	1-3/8"
600006	3/8" 1.3.7.	6"	3" D.I.D.	1-3/8"
600007	3/8" 1.3.7.	6"	3" D.I.D.	1-3/8"
600008	1/2" 1.3.7.	7"	3-9/16" D.I.D.	1-1/2"
600009	1/2" 1.3.7.	7"	3-9/16" D.I.D.	1-1/2"
600012	3/4" 1.3.7.	10"	4-11/16" D.I.D.	1-7/8"
600013	3/4" 1.3.7.	10"	4-11/16" D.I.D.	1-7/8"
600016	1" 1.3.7.	10"	4-11/16" D.I.D.	1-7/8"
600017	1" 1.3.7.	10"	4-11/16" D.I.D.	1-7/8"

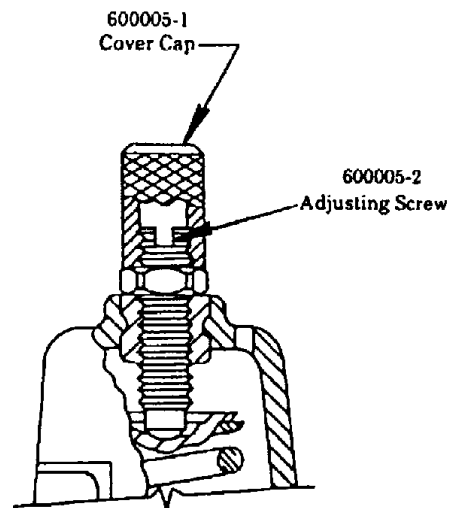

**MODEL 600002  
Tamper-Proof  
Air Regulator**

Same as Model 600005 except for design changes shown above. Regulator set at 40 psi by the manufacturer.

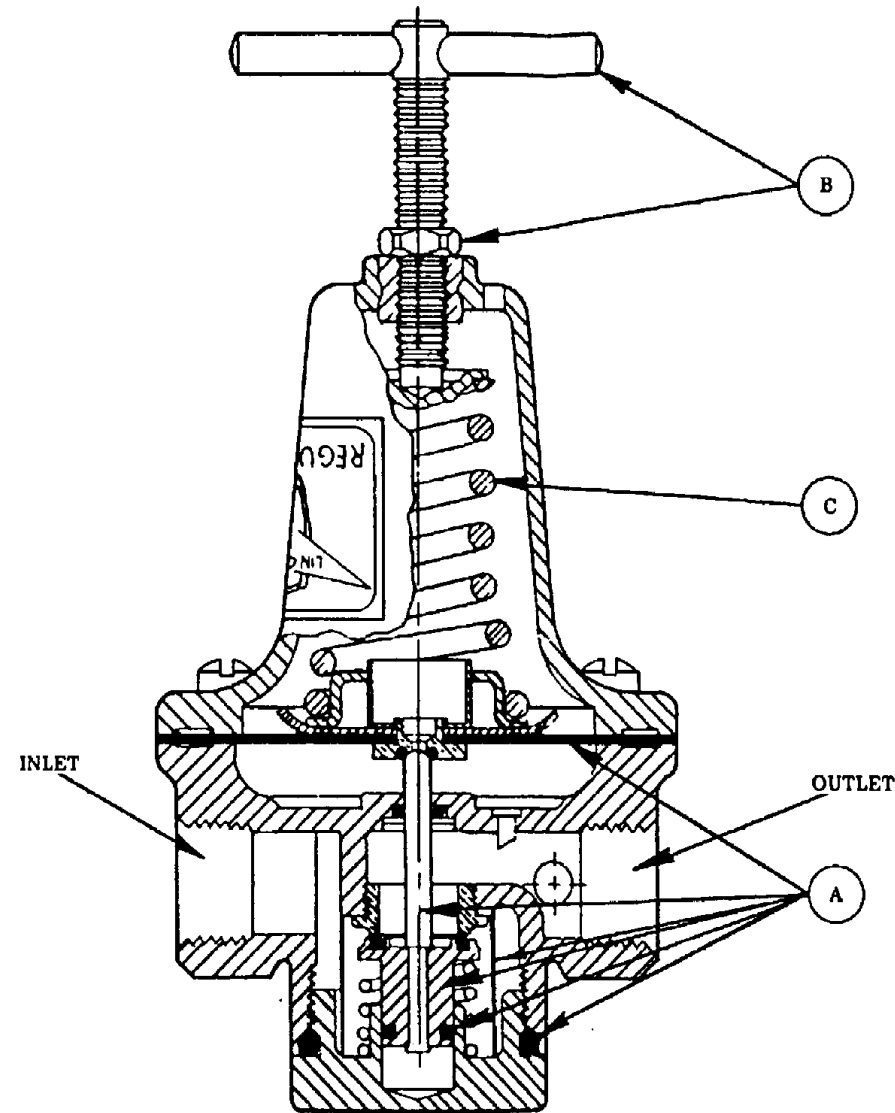

Air Regulators can be adjusted to shut off air completely when desired.

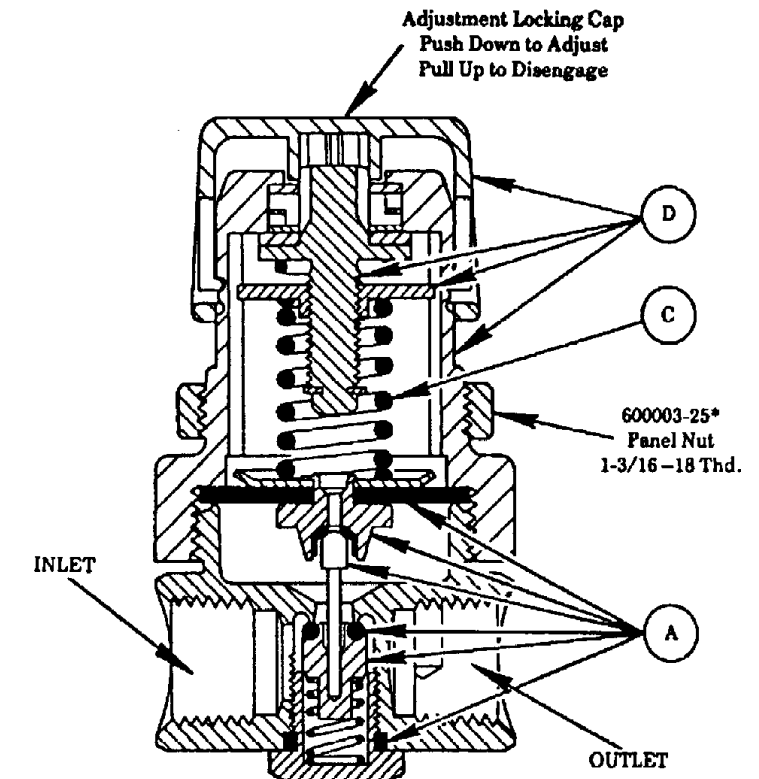

**MODEL 600003  
Miniature Air Regulator  
(Relieving Type)**

\*Must be ordered separately

CODE	DESCRIPTION	600002	600003	600004 600006	600005 600007	600008	600009	600012 600016	600013 600017
A	Diaphragm Kit	600004-150	600003-150	600004-150	600004-150	600008-150	600008-150	600012-150	600012-150
B	Tee Handle Kit			600004-151	600004-151	600008-151	600008-151	600012-151	600012-151
C	Spring	600005-3	©600003-154	600004-31	600005-3	600004-31	600009-1	600012-32	600013-1
D	Knob Assembly Kit		©600003-153						

© Indicates Change

# **INSTALLATION AND OPERATING INSTRUCTIONS** **FOR 60000 SERIES REGULATORS**

## **INSTALLATION**

In piping up, always be sure pipe ends are reamed to assure a smooth flow.

Before installing regulator:

- a. Always blow out line to remove scale or other foreign matter.
  - b. Apply pipe compound sparingly to male threads only.
1. The piping connections are marked on each port on the underside of the regulator body (except for Model 600003). The regulator should be installed in the line so that air flow is from IN to OUT. 1/4" NPTF holes on sides are normally for gauge use but may be used for outlet or service purposes.
  2. Install a shut-off valve ahead of all equipment. It is recommended that a filter be installed directly ahead of the regulator. On air lines, if excessive condensation exists, a condensate trap (automatic type preferred) should be installed.
  3. It is recommended that the regulator be installed as near as possible to the point of use or the equipment it is supplying.

## **ADJUSTMENT**

With relieving type regulators, the regulated pressure may be increased or decreased without venting the regulated pressure system. To increase pressure turn adjusting screw clockwise, to decrease pressure turn screw counterclockwise.

## **MAINTENANCE**

To obtain best efficiency and longest periods of trouble-free service, the air supply must be kept clean through the use of a filter ahead of the regulator (Figure 1). Clean filter periodically.

1. INSPECTION: The condition of the regulator may be indicated by the regulated pressure.

Regulated pressure—Unsteady regulated pressure or deviation from normal setting usually indicates:

- a. Diaphragm swollen or stiffened—replace diaphragm. (Kit A)
  - b. Inner valve disc dirty or worn, or seat is scored. Clean or replace. (Kit A)
  - c. Air line filter may require cleaning or supply valve may be partially closed.
  - d. Air leakage through vent in cage.—If constant relief is noted, it may be caused by a dirty or worn inner valve requiring cleaning or replacement. (Kit A) Intermittent relief of excess regulated air pressure is normal.
2. REPLACEMENT OF PARTS:

Diaphragm—Release spring tension by turning adjusting tee handle counterclockwise. Remove 6 flange screws and spring cage.

Reassemble new diaphragm assembly (Kit A) to body. NOTE: Make sure diaphragm gasket is in place before replacing spring cage.

Tighten cage firmly to body and reset valve as instructed under adjustment.

Inner Valve—Remove bottom plug, strainer, bottom spring and inner valve assembly. Wipe seat clean, insert new inner valve assembly and replace bottom spring, bottom plug and strainer. (Kit A)

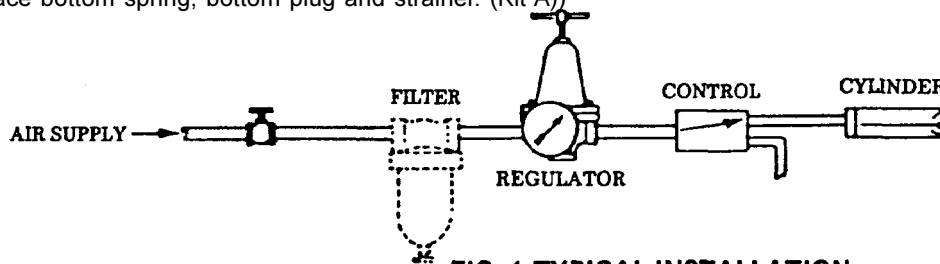

**FIG. 1 TYPICAL INSTALLATION**

### **RETAIN THIS INFORMATION FOR FUTURE REFERENCE**

When ordering replacement parts, last Part Number, Description, Model Number, and Series Letter.

LINCOLN ST. LOUIS provides a Distributor Network that stocks equipment and replacement parts.

A list of Authorized Service Departments will be furnished upon request.