

**602008 - 1/2" PORTS, T-BAR ADJUSTMENT**  
**602009 - 1/2" PORTS, KNOB ADJUSTMENT**

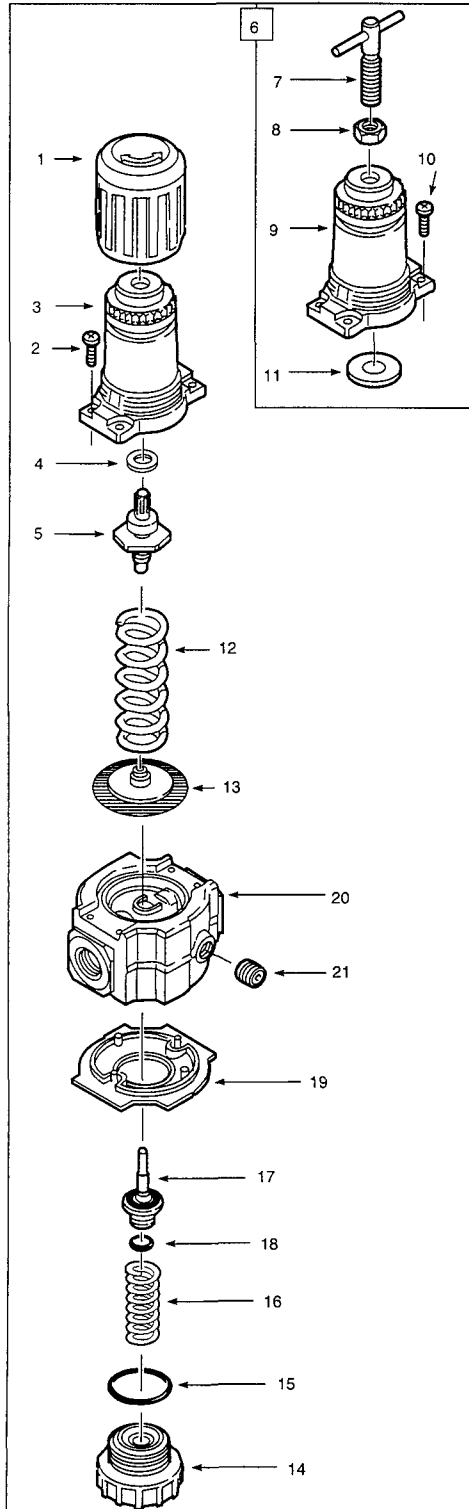

**TECHNICAL DATA**

Fluid: Compressed air  
Maximum pressure: 300 psig (20 bar)  
Operating temperature: 0° to 175°F (-20° to 79°C)\*

\* Air supply must be dry enough to avoid ice formation at temperatures below 35°F (2°C).

Main ports: 1/2" PTF

Gauge ports: 1/4" PTF

Outlet pressure adjustment ranges:

Model 602009: 5 to 150 psig (0.3 to 10 bar)\*\*

Model 602008: 10 to 250 psig (0.7 to 17 bar)\*\*

\*\* Outlet pressure can be adjusted to pressures in excess of, and less than, those specified. Do not use these units to control pressures outside of the specified ranges.

**Materials:**

- Body: Aluminum
- Bonnet: Aluminum
- Valve: Brass
- Elastomers: Nitrile
- Bottom Plug: Acetal

**REPLACEMENT ITEMS AND ACCESSORIES**

- Service Kit (13, 15, 16, 17, 18) ..... 247879
- Tamper resistant cover (knob adjustment only) ..... 247778

**PANEL MOUNTING DIMENSIONS**

Panel mounting hole diameter: 2.06" (52 mm)  
Panel thickness: 0.06" to 0.25" (2 to 6 mm)

**INSTALLATION**

1. Install regulator in air line at any angle -
  - upstream of cycling valves,
  - with air flow in direction of arrow on body,
  - as close as possible to the device being serviced.
2. Connect piping to proper ports using pipe thread sealant on male threads only. Do not allow sealant to enter interior of regulator.
3. Install a pressure gauge or plug the gauge ports. Gauge ports can also be used as additional outlets for regulated air.
4. Install a general purpose filter upstream of the regulator.

**ADJUSTMENT**

1. Turn adjustment clockwise to increase pressure setting. Turn adjustment counterclockwise to decrease pressure setting.
2. Always approach the desired pressure from a lower pressure. When reducing from a higher to a lower setting, first reduce to some pressure less than that desired, then bring up to the desired pressure.
3. **KNOB ADJUSTMENT.** Push knob down to lock pressure setting. Pull knob up to release. Install tamper resistant cover (see **Replacement Items and Accessories**) to make setting tamper resistant.

4. **T-BAR ADJUSTMENT.** Tighten lock nut (8) to lock pressure setting.

**DISASSEMBLY**

1. Shut off inlet pressure. Reduce pressure in inlet and outlet lines to zero.
2. Turn adjustment (1 or 7) fully counterclockwise.
3. Unit can be disassembled without removal from air line.
4. Disassemble in general accordance with the item numbers on exploded view.

**CLEANING**

1. Clean parts with warm water and soap.
2. Rinse and dry parts. Blow out internal passages in body with clean, dry compressed air.
3. Inspect parts. Replace parts found to be damaged.

**ASSEMBLY**

1. Lubricate o-rings, valve stem (17), tip of adjusting screw (7), and the outer circumference and both sides of the thrust washer (4) with a light coat of good quality o-ring grease.
2. Assemble the unit as shown on the exploded view.
3. Torque Table
 

	Inch-Pounds (N-m)
2, 10 (screw)	25 to 35 (2.8 to 3.9)
14 (bottom plug)	20 to 30 (2.3 to 3.4)

**WARNING**

These products are intended for use in industrial compressed air systems only. Do not use these products where pressures and temperatures can exceed those listed under **Technical Data**.

If outlet pressure in excess of the regulator pressure setting could cause downstream equipment to rupture or malfunction, install a pressure relief device downstream of the regulator. The relief pressure and flow capacity of the relief device must satisfy system requirements.

The accuracy of the indication of pressure gauges can change, both during shipment (despite care in packaging) and during the service life. If a pressure gauge is to be used with these products and if inaccurate indications may be hazardous to personnel or property, the gauge should be calibrated before initial installation and at regular intervals during use.

Do not use these products with fluids other than air, for non industrial applications, or for life-support systems.