

# HIGH PRESSURE PUMP

25 OR 35 LB. ORIGINAL CONTAINER

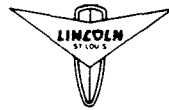

# Model 1292

# Series "D"

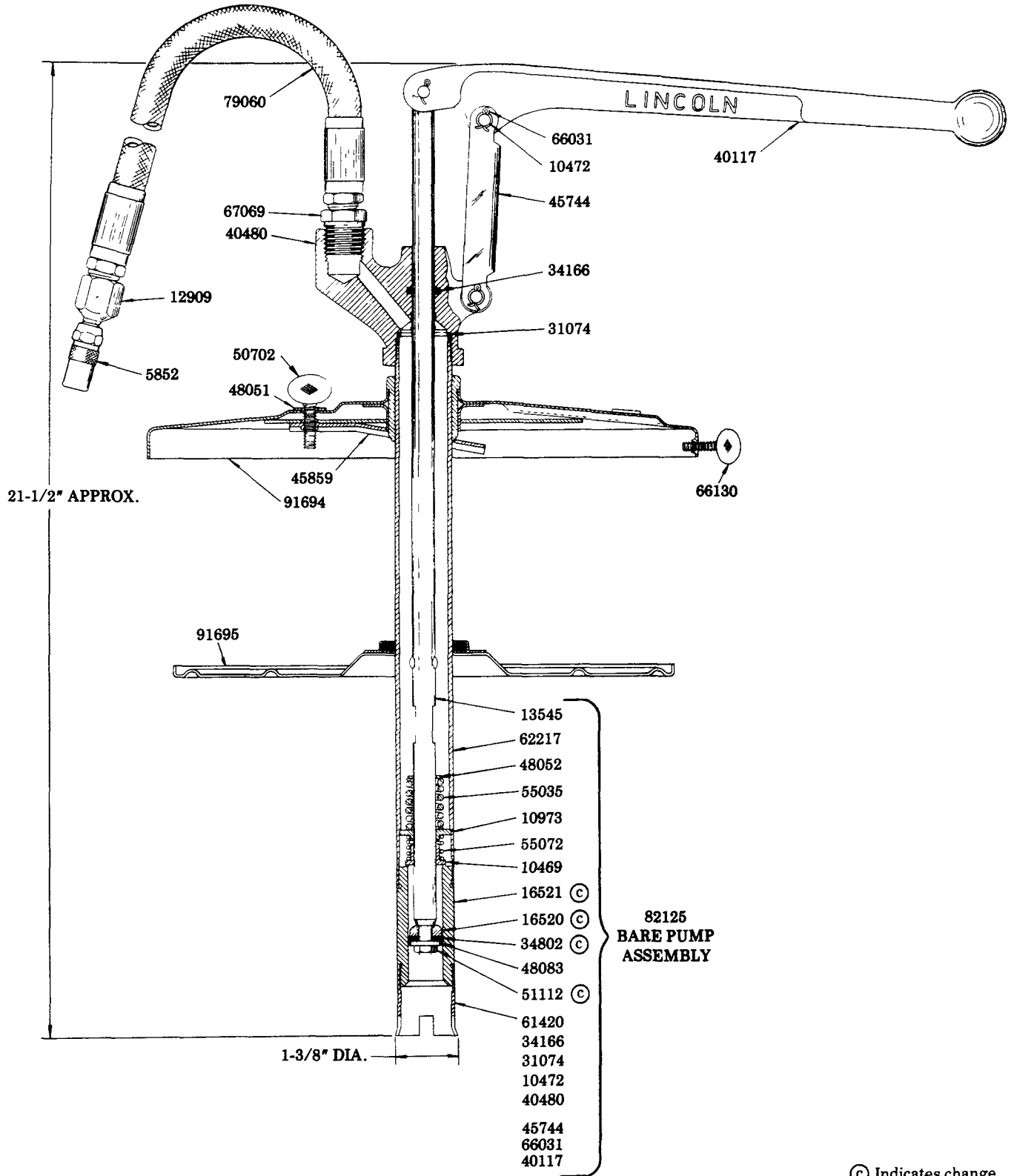

**LINCOLN ST. LOUIS**  
4010 GOODFELLOW BLVD · ST. LOUIS, MO 63120 · (314) 383 5900

A DIVISION OF  
**McNEIL**  
CORPORATION

SECTION - **J24**  
PAGE - **16C**

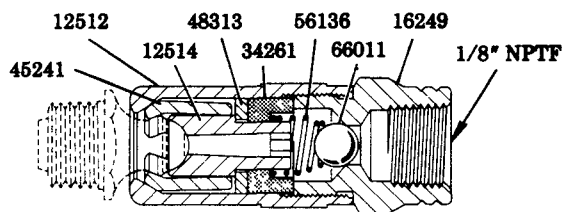

## 5852 HYDRAULIC COUPLER

### WIPE FITTING CLEAN BEFORE LUBRICATING

Push COUPLER on to FITTING at a slight angle, then center COUPLER on FITTING. COUPLER JAWS grip FITTING HEAD forming a tight seal when LUBRICANT pressure is developed by the LEVER GUN. To remove COUPLER turn at slight angle to release grip of COUPLER JAWS. For replacement JAWS order No. 82154 KIT which contains 6 No. 45241 JAWS.

The Model 1292 PUMP is manually operated to dispense grease from a 25 or 35 pound ORIGINAL CONTAINER.

The DRUM COVER is adjustable for various height CONTAINERS. A CLAMP, 45859, is provided to secure PUMP to DRUM COVER by tightening the THUMB SCREW, 50702.

Three THUMB SCREWS, 66130, hold the DRUM COVER to the CONTAINER.

## OPERATING INSTRUCTIONS

Raise PUMP HANDLE until a slight resistance to the upward movement of the HANDLE can be felt. (Position "B"). To insure maximum lubricant delivery, the full pumping range from position "B" to the bottom stop, (position "C") should be used.

## AUTOMATIC PRESSURE RELEASE

The slight resistance felt when the PUMP HANDLE is raised to position "B" indicates the venting range. Venting range is between positions "A" and "B."

Before removing COUPLER from FITTING, after lubrication is completed, raise PUMP HANDLE to position "A". This opens a CHECK VALVE which allows the lubricant to drain from HOSE, through the PUMP TUBE and back into the CONTAINER.

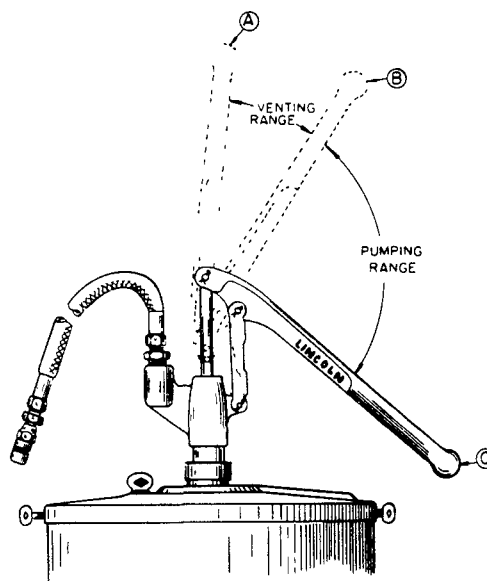

## SERVICE PARTS

PART	QUAN.	DESCRIPTION	PART	QUAN.	DESCRIPTION	PART	QUAN.	DESCRIPTION
5852	1	Hydraulic coupler	34261	1	Coupler packing	55035	1	Spring
10469	1	Pump check	34802	1	Piston packing	55072	1	Check spring
10472	3	Toggle pin	40117	1	Handle	56136	1	Spring
10973	1	Stop washer	40480	1	Outlet body	61420	1	Cylinder tube
12512	1	Coupler cap	45241	3	Coupler jaw	62217	1	Pump tube
12514	1	Nozzle body	45744	1	Toggle	66011	1	Ball
12909	1	Adapter	45859	1	Clamp	66031	3	Cotter pin
13545	1	Connecting rod	48051	1	Washer	66130	3	Thumb screw
16249	1	Coupler body	48052	1	Washer	67069	1	Adapter
16520	1	Piston washer (upper)	48083	1	Piston washer (lower)	79060	1	Hose
16521	1	Pump cylinder	48313	1	Packing washer	82125	1	Bare pump assembly
31074	1	Gasket	50702	1	Thumb screw	91694	1	Drum cover
34166	1	O-ring	51112	1	Connecting rod nut	91695	1	Follower

### RETAIN THIS INFORMATION FOR FUTURE REFERENCE

When ordering replacement parts, list: Part Number, Description, Model Number, and Series Letter.

LINCOLN ST. LOUIS provides a Distributor Network that stocks equipment and replacement parts.

A list of Authorized Service Departments will be furnished upon request.