

FOR MODELS 83271, 83398, 84995 & 84996 PUMP TUBES

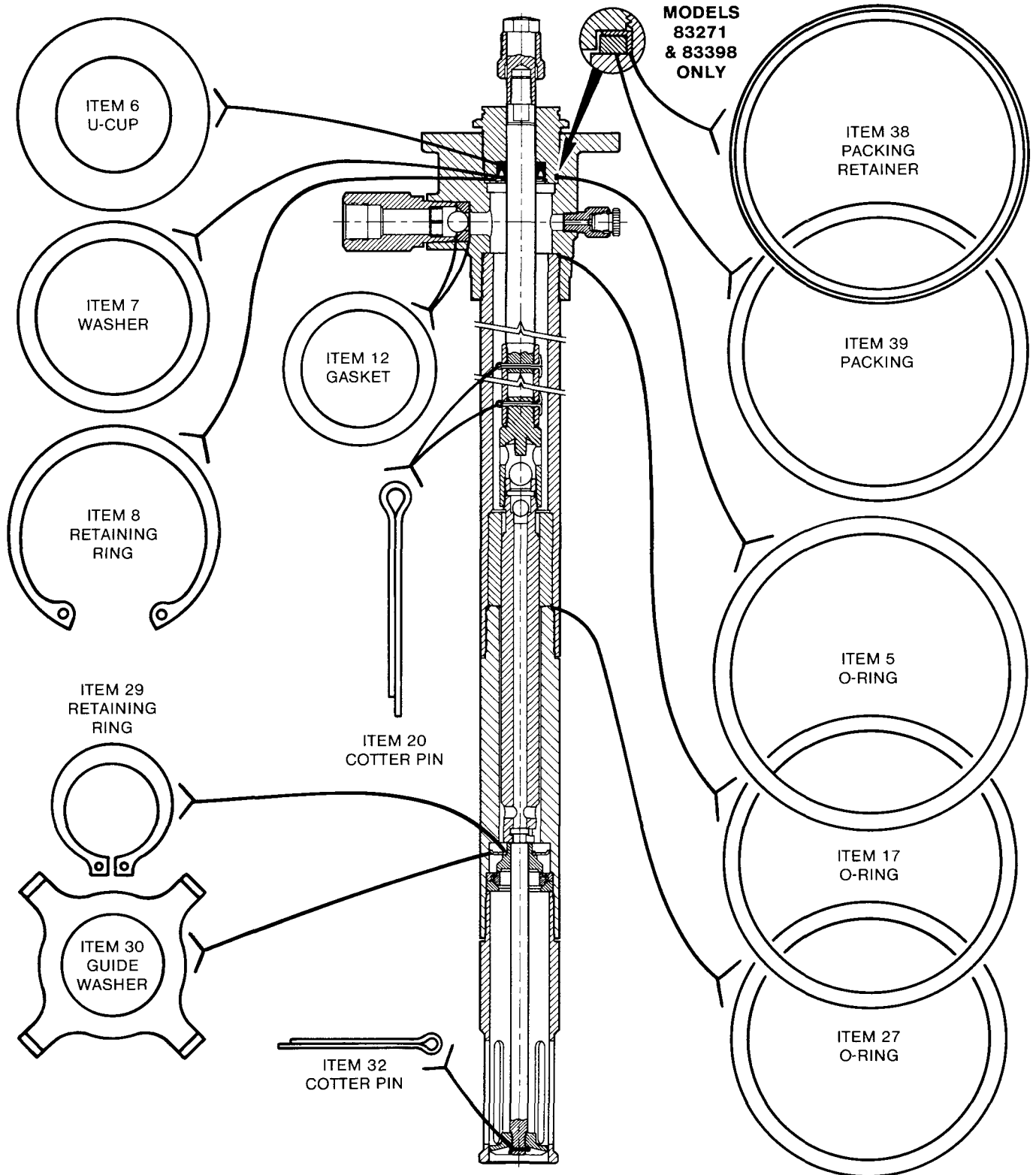

ALL COMPONENTS SHOWN ACTUAL SIZE

DISASSEMBLY

Tools Required

- 2-1/8" Dia. Strap Wrench
- Retaining Ring Pliers (External)
- Retaining Ring Pliers (Internal)
- 19/32" Hex Wrench
- 5/8" Hex Wrench
- 11/16" Hex Wrench
- 7/8" Hex Wrench
- 13/16" Hex Wrench
- 1-3/8" Hex Wrench
- 2-1/4" Hex Wrench
- Pliers

Procedure

1. Unscrew Adapter Tube (Item 28) from Pump Tube (Item 18).
2. Pull on Adapter Tube (Item 28) until connection between Bushing & Plunger (Item 26) and Bushing & Plunger (Item 31) is exposed and can be disconnected.
3. Remove Priming Tube (Item 37) from Adapter Tube (Item 28).
4. Remove Lower Check Assembly (Items 29, 30, 31, 33, 34 & 35) from Adapter Tube (Item 28).
5. Remove Cotter Pin (Item 32) from Bushing & Plunger (Item 31).
6. Remove Priming Shovel (Item 36) from Bushing & Plunger (Item 31).
7. Remove Retaining Ring (Item 29) and Guide Washer (Item 30) from Bushing & Plunger (Item 31).
8. Remove O-ring (Item 27) from Pump Tube (Item 18).
9. On Models 83271 and 83398 remove Coupling Nut (Item 2) from Plunger (Item 3).
- On Models 84995 and 84996 remove Bolt Connector (Item 1) and Coupling Nut (Item 2) from Plunger (Item 3).
10. Pull Bushing & Plunger (Item 26) to remove Plunger (Item 3), Connecting Rod (Item 21), Adapter (Item 22) and Bushing & Plunger from Pump Tube (Item 18).
11. Remove Pump Tube (Item 18) from Outlet Body (Item 9).
12. Remove O-ring (Item 17) from Outlet Body (Item 9).
13. Remove Gland Nut (Item 4) from Outlet Body (Item 9).
14. Remove Priming Plug (Item 10) and Adapter (Item 11) from Outlet Body (Item 9).
15. Remove Outlet Body (Item 16) from Outlet Body (Item 9).
16. Remove Ball (Item 14), Check Seat (Item 13), and Gaskets (Item 12) from Outlet Body (Item 9).
17. Remove Retaining Ring (Item 8), Packing Washer (Item 7) and U-cup Packing (Item 6) from Gland Nut (Item 4).
18. On Models 83271 and 83398 remove Packing Retainer (Item 38) and Packing (Item 39) from Outlet Body (Item 9).

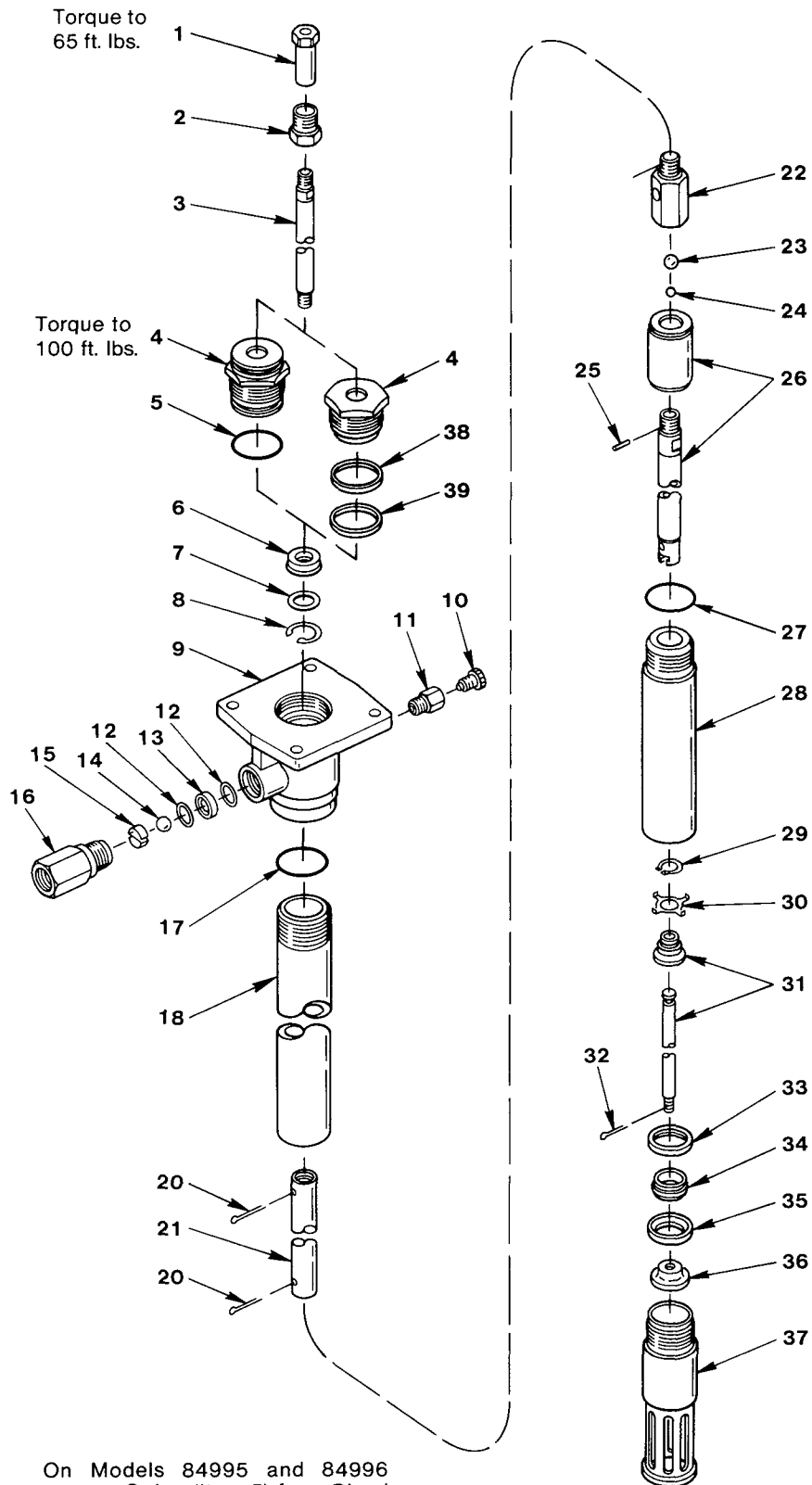

- On Models 84995 and 84996 remove O-ring (Item 5) from Gland Nut (Item 4).
19. Remove Bushing & Plunger (Item 26) from Adapter (Item 22).
20. Remove Ball (Item 23) from Adapter (Item 22).
21. Remove Pin (Item 25) and Ball (Item 24) from Bushing & Plunger (Item 26).

22. Remove Cotter Pins (Item 20) from Connecting Rod (Item 21).
23. Remove Adapter (Item 22) and Plunger (Item 3) from Connecting Rod (Item 21).
24. To re-assemble pump, reverse disassembly procedure. (Refer to illustration for torque specifications.)

RETAIN THIS INFORMATION FOR FUTURE REFERENCE

When ordering replacement parts, list: Part Number, Description, Model Number and Series Letter.

LINCOLN provides a Distributor Network that stocks equipment and replacement parts.