

### MODEL 83671

Used on:  
1849, 82653, 82655, 83551  
(From Series D)  
83167, 83599, 83668, 83834,  
83800 (From Series A)

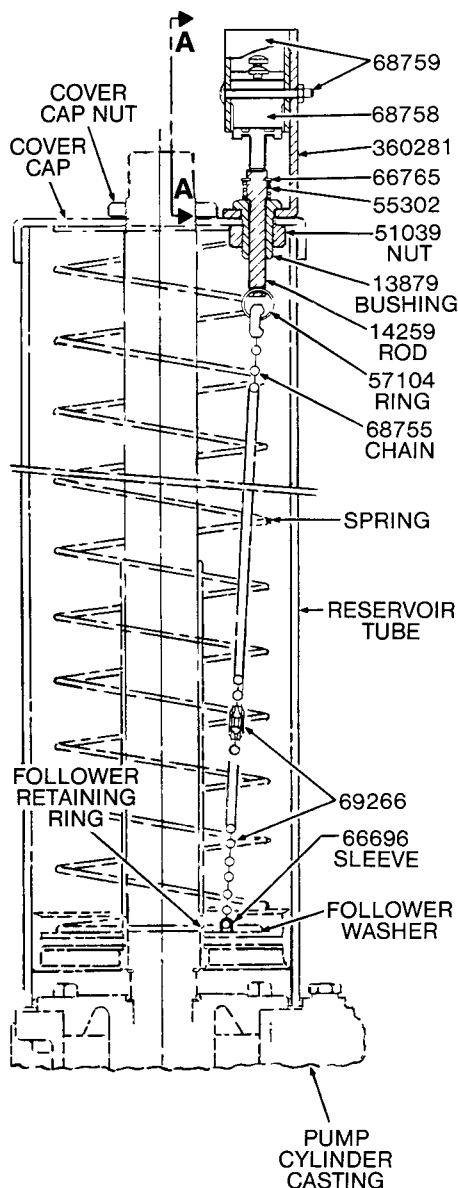

### TO ADAPT PUMPS FOR AN AUDIBLE OR VISUAL ALARM SYSTEM

\* When kit is used on 82653, 82655, 83551, 83834, 83800 Pumps, the 69266 Bead Chain Extension should be discarded.

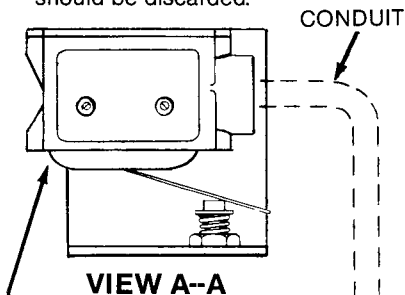

68758 Switch is a single pole double throw type Micro-Switch which permits wiring it into the circuit of the timer and solenoid valve or switch can be wired to sound an alarm or light a lamp.

### OPERATION

When grease in reservoir drops below a set level the Chain actuates the Micro-Switch which shuts off the electrical current to the timer and solenoid valve thereby shutting off the pump or the alarm will sound or alarm lamp will light.

### INSTALLATION

Remove the following parts from the pump:

Cover Cap Nut, Plug Button (to be discarded), Cover Cap, Reservoir Tube and Follower Retaining Ring.

Install parts contained in the 83671 Kit.

1. Remove the 57104 Ring and Chain from the 14259 Rod.
2. Remove the 66696 Sleeve from the end of Chain.\* Slide Follower Washer up so that end of Chain can be inserted through hole that is in Washer. Reassemble 66696 Sleeve on end of Chain and pull up on Chain until Sleeve fits snugly in hole in Washer.
3. Push, Follower Washer against Packing and replace the Retaining Ring to hold Follower Washer in place.
4. Remove the 51039 Nut from 13879 Bushing on switch bracket. Insert Rod and Bushing through hole in Cover Cap (from which Plug Button was removed).\*\* Replace 51039 Nut on Bushing and tighten to hold switch assembly securely to Cover Cap.

5. Replace Reservoir Tube onto the pump cylinder casting. Pull Chain up so that the 57104 Ring can be attached to the 14259 Rod.

6. Place Cover Cap with switch assembly onto Reservoir Tube and hold in place with the Cover Cap Nut. Tighten to specified foot pounds of torque. (See service manual sheets for pumps).

**Note:** For pumps kit is used on, refer to the following Service Manual Sheets:

1849 - Sec. C8, Page 67 Series  
82653 - Sec. C8, Page 52 Series  
82655 - Sec. C8, Page 53 Series  
83167 - Sec. C8, Page 85 Series  
83668 - Sec. C8, Page 127 Series  
83834 - Sec. C8, Page 130 Series  
83800 - Sec. C8, Page 131 Series

\*\* When Kit is installed on 83599 Pump, the Pump Indicator Rod parts will have to be removed. Kit is then installed in the usual manner.

### REPAIR PARTS LIST

Part No.	Description
13879	Bushing
14259	Rod
51039	Hex. Nut
55302	Spring
57104	Ring
66696	Sleeve
66765	Retaining Ring
68755	Chain
68758	Micro-Switch
68759	Terminal Enclosure
69266	Bead Chain Extension
360281	Bracket

## Model 83696 (Oil)

Use on the following pumps:  
82570, 82571 (From Series D)  
1848, 82573, 83550 (From Series E)  
83667, 283167 (From Series A)

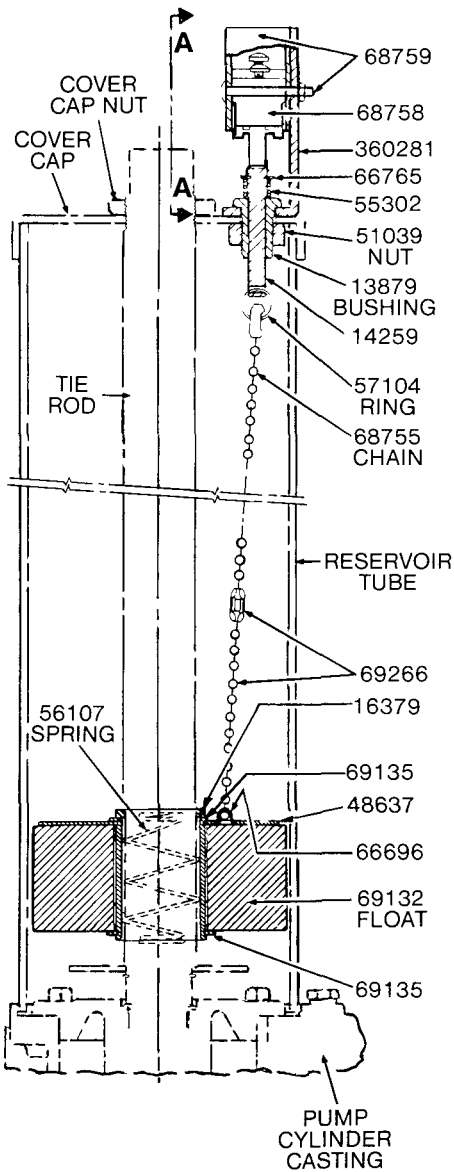

\* When kit is used on 82570, 82571, 82573, 83550 and 83667 Pumps, the 69266 Bead Chain Extension should be discarded.

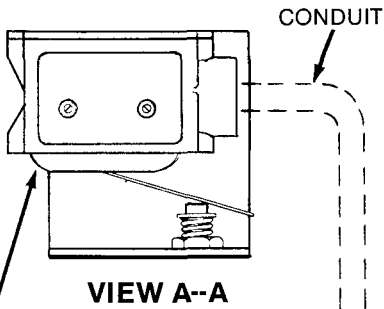

68758 Switch is a single pole double throw type Micro-Switch which permits wiring it into the circuit of the timer and solenoid valve or switch can be wired to sound an alarm or light a lamp.

### OPERATION

When oil in reservoir drops below a set level the Float Chain actuates the Micro-Switch which shuts off the electrical current to the timer and solenoid valve thereby shutting off the pump or the alarm will sound or alarm lamp will light.

### INSTALLATION

Remove the following parts from the pump:

Cover Cap Nut, Plug Button (to be discarded) and Cover Cap.

Install parts contained in the 83696 kit.

1. Remove the 57104 Ring and Chain from the 14259 Rod.
2. Remove the 51039 Nut from 13879 Bushing on switch bracket. Insert Rod and Bushing through hole in Cover Cap (from which Plug Button was removed). Replace 51039 Nut on Bushing and tighten to hold switch assembly securely to Cover Cap. Replace 57104 Ring and Chain on the 14259 Rod.\*
3. Insert Float Assembly into Reservoir Tube. The 56107 Spring is not used when kit is installed on Model 83667 Pump. Spring is used when kit is installed on Models 1848, 82570, 82571, 82573, 83550 and 283167 Pumps. Spring is slipped over the Tie Rod and into the center of the Float.
4. Place Cover Cap with switch assembly onto Reservoir Tube and hold in place with the Cover Cap Nut. Tighten to specified foot pounds of torque. (See service manual sheets for pumps).

**Note:** For pumps kit is used on, refer to the following Service Manual Sheets:

1848 - Sec. C8, Page 66 Series  
82570 - Sec. C8, Page 43 Series  
82571 - Sec. C8, Page 46 Series  
82573 - Sec. C8, Page 47 Series  
83667 - Sec. C8, Page 126 Series  
283167 - Sec. C8, Page 101 Series

### REPAIR PARTS LIST

Part No.	Description	Part No.	Description	Part No.	Description
13879	Bushing	56107	Barrel Spring	68759	Terminal Enclosure
16379	Guide Sleeve	57104	Ring	69132	Float
14259	Rod	66696	Sleeve	69135	Retaining Ring
48637	Washer	66765	Retaining Ring	69266	Bead Chain Extension
51039	Nut	68755	Chain	360281	Bracket
55302	Spring	68758	Micro-Switch		

### RETAIN THIS INFORMATION FOR FUTURE REFERENCE

When ordering replacement parts, list: Part Number, Description, Model Number, and Series Letter.

LINCOLN provides a Distributor Network that stocks equipment and replacement parts.