

TEFLON KIT

FOR 83614 PUMP TUBE ASSEMBLY
SERIES "A" & "B"

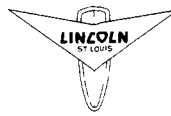

Model 83961

The Teflon Gland and Piston Packing Kit should be used when dispensing materials which are not compatible with the standard Polyurethane and Buna-N Packings.

STANDARD PUMP GLAND

Remove the following parts; 31114,
34401, 34415, 34424, 69277, 92288.

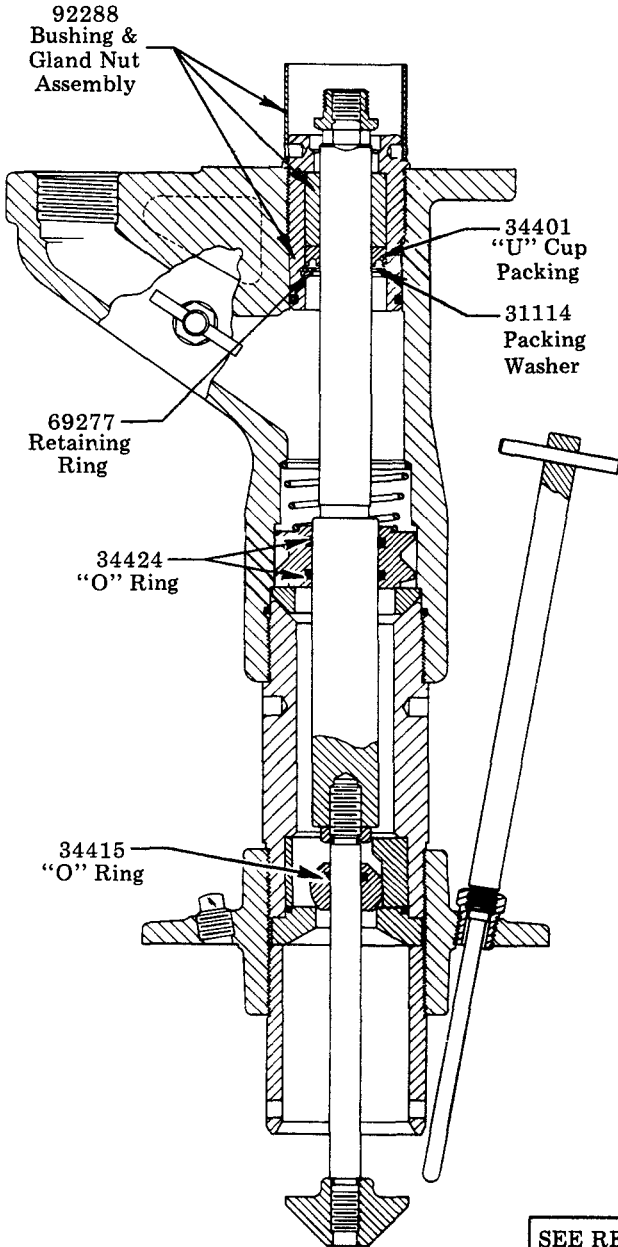

STANDARD PUMP GLAND

Remove the following parts; 31114,
34401, 34415, 34424, 34529, 69277, 92288.

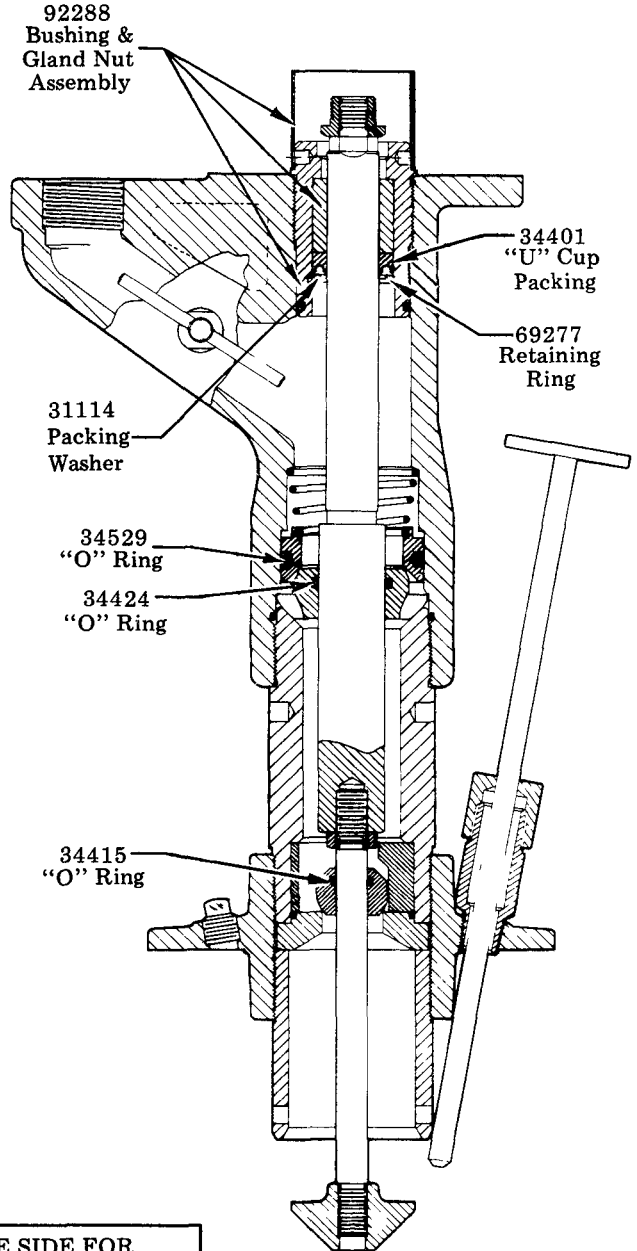

SEE REVERSE SIDE FOR
TEFLON PACKING KIT
INSTALLATION PROCEDURE

Series "A"
83614 Pump Tube Assembly

Series "B"
83614 Pump Tube Assembly

LINCOLN ST. LOUIS
4010 GOODFELLOW BLVD • ST LOUIS, MO 63120 • (314) 383 5900



A DIVISION OF
McNEIL
CORPORATION

SECTION - **K4**
PAGE - **20**

INSTALLATION PROCEDURE

Invert 38130 U-Cup Packing and force over Piston Rod. (This is done to "size" the packing bore.)

Remove 38130 U-Cup Packing from Piston Rod.

Assemble all parts in the Gland Assembly. Do not tighten the 14747 Spreader Nut at this time.

Insert Piston Rod up through Gland Assembly and tighten the 14747 Spreader Nut.

Screw Gland Assembly with Piston Rod into pump outlet casting.

Series "B"

Insert 34534 O-Ring on 14647 Check and install in pump.

Series "A"

Insert two 34541 O-Rings into Upper Check Bushing and install in pump.

Series "B"

Install one 34541 O-Ring into Check Bushing and install in pump.

Insert 34536 O-Ring into Foot Valve Check and install on Priming Rod.

Complete assembly of pump tube.

NOTE: 34534 "O" Ring and 14647 Check must be fully depressed into outlet body before assembling lower section parts.

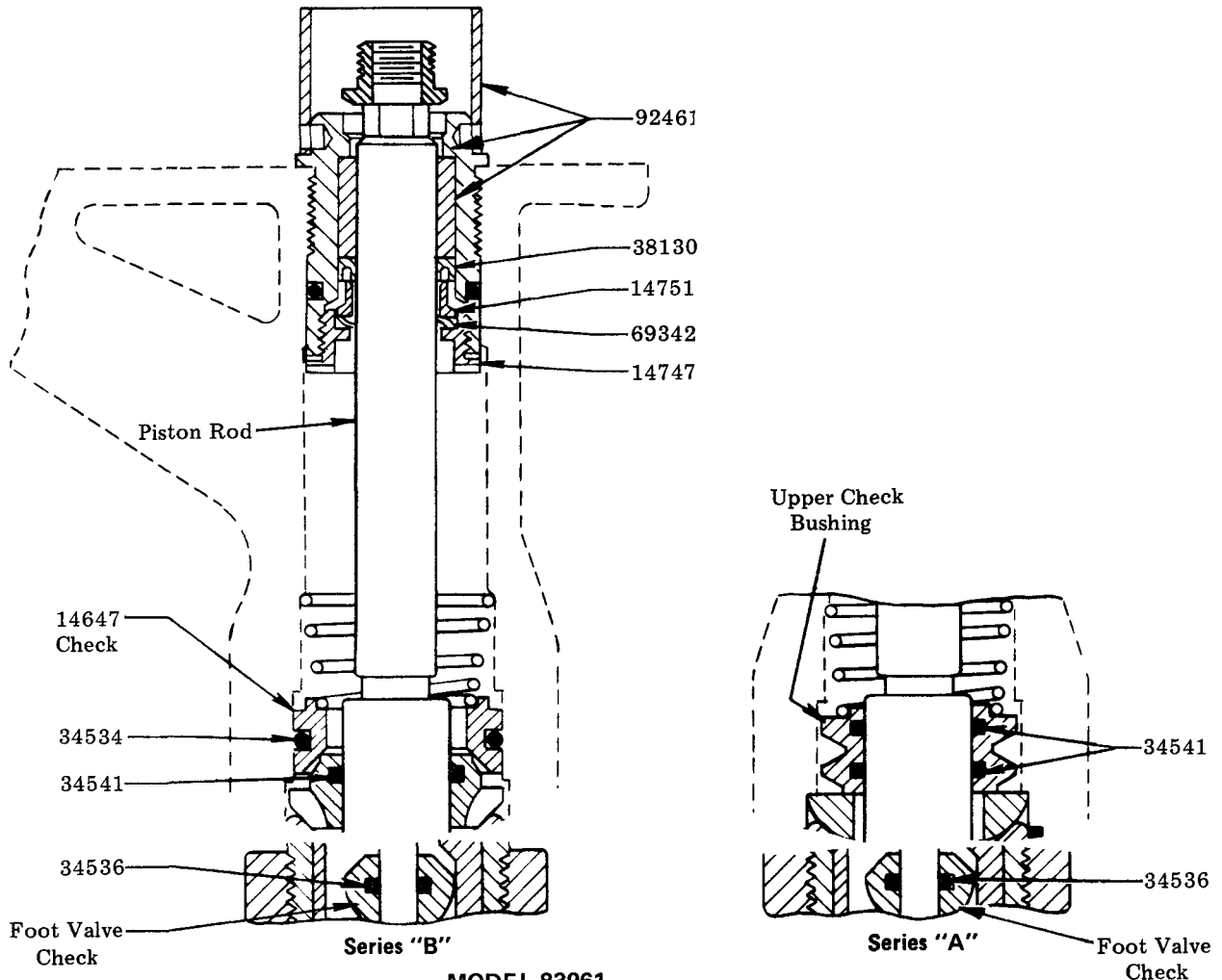

MODEL 83961

PART NO.	QUAN.	DESCRIPTION
14747	1	Spreader Nut
14751	1	Spreader
34534	1	O-Ring
34536	1	O-Ring
34541	2	O-Ring
38130	1	U-Cup Packing
69342	1	Wave Washer
92461	1	Bushing and Gland Nut Assembly

RETAIN THIS INFORMATION FOR FUTURE REFERENCE

When ordering replacement parts, list: Part Number, Description, Model Number, and Series Letter.

LINCOLN ST. LOUIS provides a Distributor Network that stocks equipment and replacement parts.

A list of Authorized Service Departments will be furnished upon request.