

# TEFLON KIT

FOR 83604 PUMP TUBE ASSEMBLY



# Model 83964

## TO CONVERT PACKING GLAND

The Teflon Gland and Piston Packing Kit should be used when dispensing materials which are not compatible with the standard Polyurethane and Buna-N Packings.

### STANDARD PUMP GLAND

Remove the following parts;  
92115, 69280, 34427, 34425, 34529.

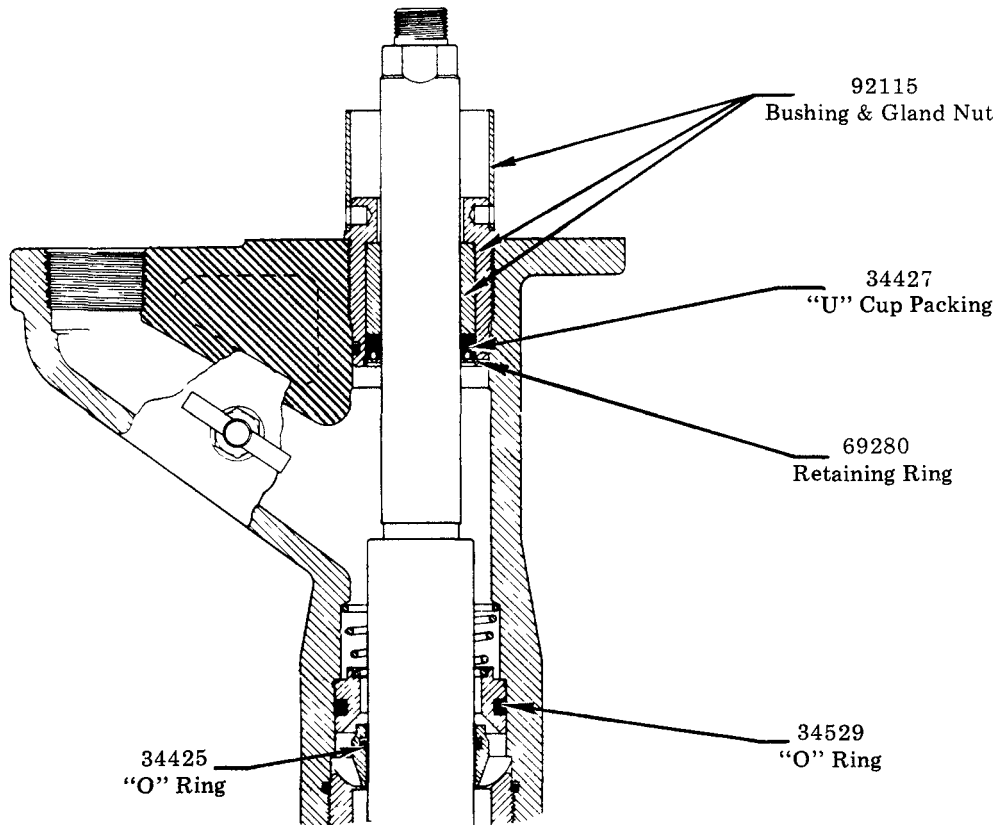

SEE REVERSE SIDE FOR  
"TEFLON" PACKING KIT  
INSTALLATION PROCEDURE

**LINCOLN ST. LOUIS**  
4010 GOODFELLOW BLVD · ST LOUIS MO 63120 · (314) 383 5900



A DIVISION OF  
**McNEIL**  
CORPORATION

SECTION - **K4**  
PAGE - **25**

## INSTALLATION PROCEDURE

Invert 38140 "U" Cup Packing and force over Piston Rod. (This is done to "size" the hole in the packing.) Remove 38140 "U" Cup Packing from Piston Rod.

Assemble all parts included in the Gland Assembly. Do not tighten the 14747 Spreader Nut at this time.

Insert Piston Rod up through Gland Assembly and tighten the 14747 Spreader Nut.

Screw Gland Assembly into Pump Outlet Casting.

Insert 34534 "O" Ring into Check, and 34535 "O" Ring into Check Bushing, and slip onto Piston Rod.

Re-Assemble pump tube to complete installation of "Teflon" Packing Kit.

**NOTE:** 34534 "O" Ring and 14647 Check must be fully depressed into outlet body before assembling lower section parts.

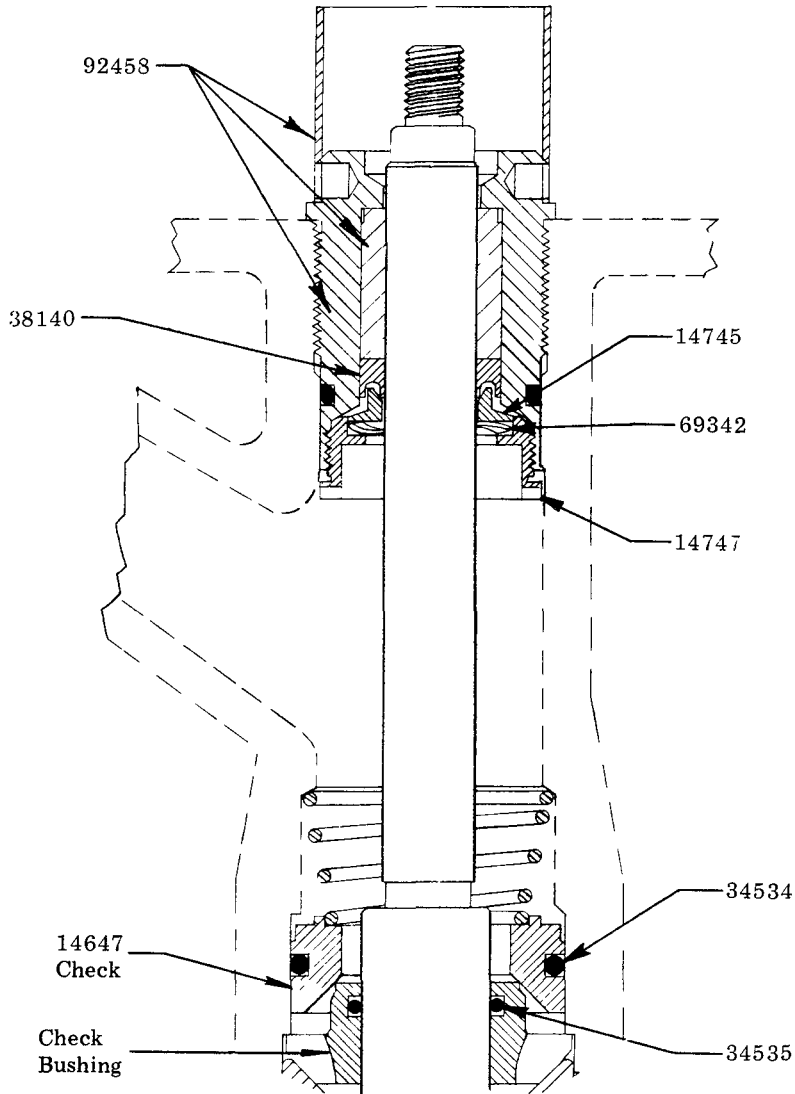

MODEL 83964

PART NO.	QUAN.	DESCRIPTION
14745	1	Spreader
14747	1	Spreader Nut
34534	1	O-Ring
34535	1	O-Ring
38140	1	"U" Cup Packing
69342	1	Wave Washer
92458	1	Bushing & Gland Nut Assembly

### RETAIN THIS INFORMATION FOR FUTURE REFERENCE

When ordering replacement parts, list: Part Number, Description, Model Number, and Series Letter.

LINCOLN ST. LOUIS provides a Distributor Network that stocks equipment and replacement parts.

A list of Authorized Service Departments will be furnished upon request.