

DRUM COVER KIT

FOR PILE DRIVER PUMP TUBES

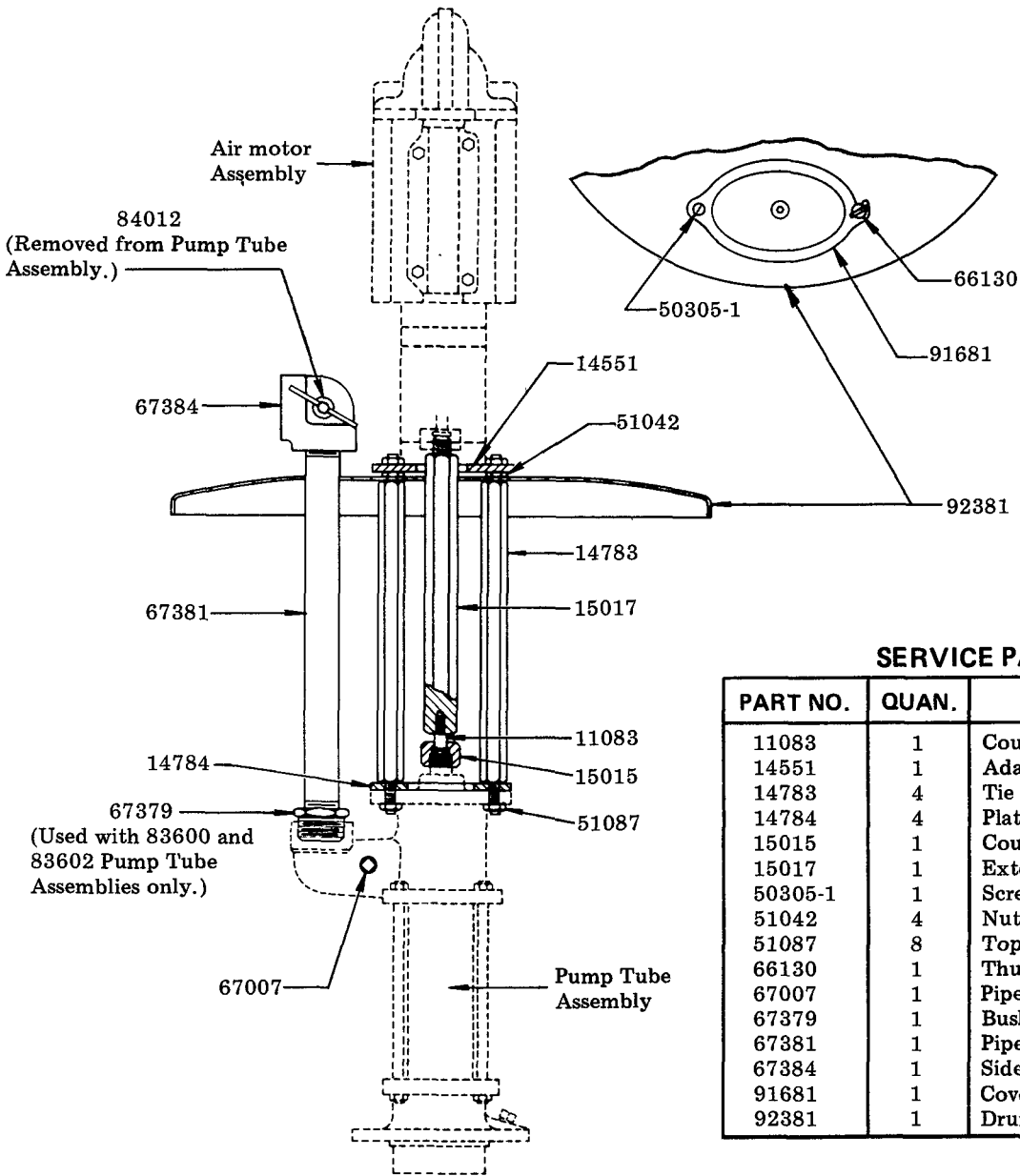

Model 83845



SERVICE PARTS

PART NO.	QUAN.	DESCRIPTION
11083	1	Coupling Stud
14551	1	Adapter Plate
14783	4	Tie Rod
14784	4	Plate
15015	1	Coupling Nut
15017	1	Extension Rod
50305-1	1	Screw
51042	4	Nut
51087	8	Toplock Nut
66130	1	Thumb Screw
67007	1	Pipe Plug
67379	1	Bushing
67381	1	Pipe Nipple
67384	1	Side Tapped 1-1/4 Elbow
91681	1	Cover Plate
92381	1	Drum Cover (400 lb.)

NOTE: This kit is for use with Pile Driver Pumps having the following Ball Foot Valve-type pump tube assemblies: 83600, 83602, 83603, 83604, 83605 and 83606.

LINCOLN ST. LOUIS
4010 GOODFELLOW BLVD. • ST. LOUIS, MO 63120 • (314) 383-5900



A DIVISION OF
McNEIL
CORPORATION

SECTION - **K4**
PAGE - **26**