

OWNERS MANUAL

IT IS THE RESPONSIBILITY OF THE OWNER AND/OR OPERATOR TO PROPERLY USE AND MAINTAIN THIS EQUIPMENT. CAREFULLY READ AND UNDERSTAND THE INSTRUCTIONS AND WARNINGS IN THIS MANUAL BEFORE OPERATING THIS EQUIPMENT.

If the operator is not fluent in English, the instructions and warnings shall be read and discussed in the operator's native language, making sure the operator comprehends the contents.

This equipment complies with OSHA Standard's where applicable.

Model 241952 is an air signal kit used to adapt Lincoln Powermaster Airmotors, Models 82730, 82736, 82737, 82895 and 83435 for use with The Pump Guardian Runaway Controller.

**WARNING**

DO NOT exceed the stated maximum pressure of the airmotor or of the lowest rated component in your system.

DO NOT alter or modify any part of this equipment.

DO NOT operate this equipment with combustible gas.

DO NOT attempt to repair or disassemble the equipment while the system is pressurized.

TIGHTEN all fluid connections securely before using this equipment.

ALWAYS read and follow the fluid manufacture's recommendations regarding fluid compatibility, and the use of protective clothing and equipment.

CHECK all equipment regularly and repair or replace worn or damaged parts immediately.

IMPORTANT: Failure to heed these warnings including misuse, overpressurizing, modifying parts, using incompatible chemicals and fluids or using worn or damaged parts, may result in equipment damage and/or serious personal injury, fire, explosion, or property damage.

**WARNING**

Electrical, shock hazard.

Turn off and lock out power before connecting external components.

Failure to do so could result in injury or death.

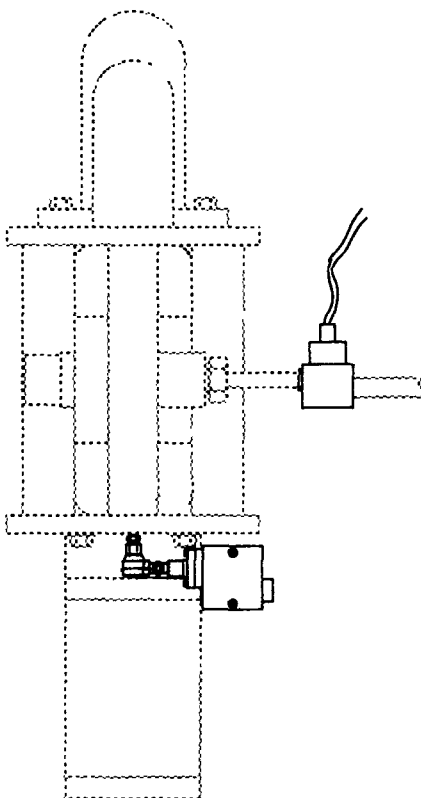
**Before Installing Air Signal Kit to the Airmotor:**

1. Relieve air pressure to the airmotor & disconnect air supply lines.
2. Remove parts 13208, 34297 & 48379 and then replace with Item's 1, 2 & 5 see View 1.
3. Remove cover from pressure switch (Item 3) & adjust pressure setting by turning the wheel see View 4.
4. Set the pressure switch 10-15 psig below the operational air pressure of the airmotor in order to make pressure switch more responsive to a pressure drop encountered if pump goes into runaway condition.
5. Replace the cover.

Installing Air Signal Kit to the Airmotor:

1. Install Nipple (Item 6) in place of removed parts.
2. Install Quick Exhaust Air Valve (Item 7) and Nipple (Item 6) according to View 2 (Check for proper "In" & "Out" positions).
3. Install Pressure Switch (Item 3). Preset pressure according to above noted procedures before installing).
4. Install Air Valve (Item 4) on air supply line according to View 3.
5. Connect Pressure Switch (Item 3) & Solenoid of Air Valve (Item 4) to the Controller Model 241818 or Model 241824 according to wiring diagram provided with the controller.

I. Principle of operation

At each pump cycle Pressure Switch (Item 3) converts exhaust air pulse to an electrical signal and transmits it to the Runaway Controller.

Controller counts number of pump cycles and compares it with preset number of cycles and time.

When a runaway occurs, number of pump cycles will exceed preset amount and controller will send a signal to the solenoid of the Air Valve (Item 4) which will close inlet air supply line and stop the pump.

The appropriate light on the controller indicates which pump has been stopped so that corrective action can be taken.

Refer to the appropriate owners manual for complete operating instructions for controller.

This manual contains **IMPORTANT WARNINGS** and **INSTRUCTIONS** READ AND RETAIN FOR REFERENCE

Item	Part No.	Description	Qty.
1	34343X	Packing	1
2	84382-1	Adaptor	1
3	241906	Pressure switch	1
4	241904	3 way solenoid valve	1
5	84382-2	Spacer	1
6	10462	Male nipple 1/4 NPTF Male, 1/4 NPTF	2
7	70361	Quick exhaust air valve	1

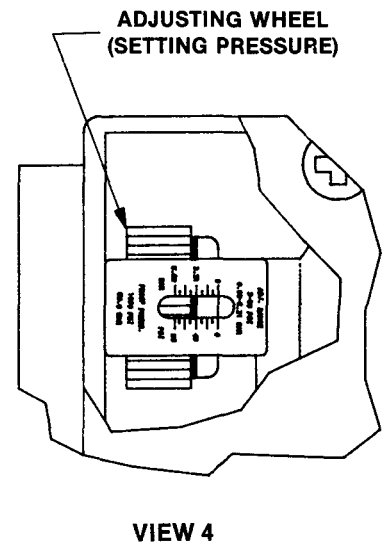
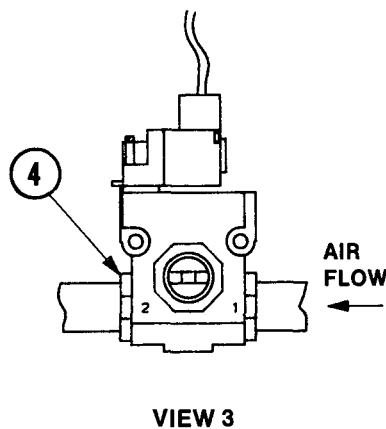
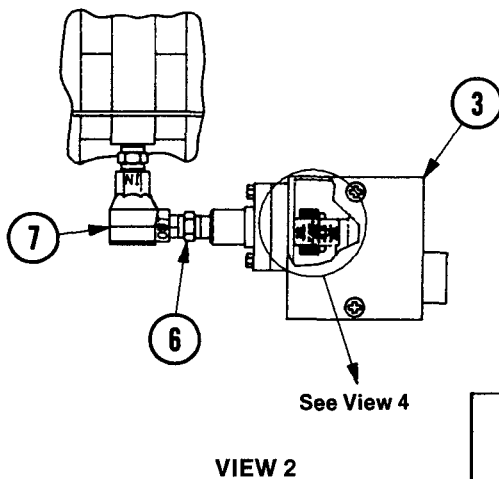
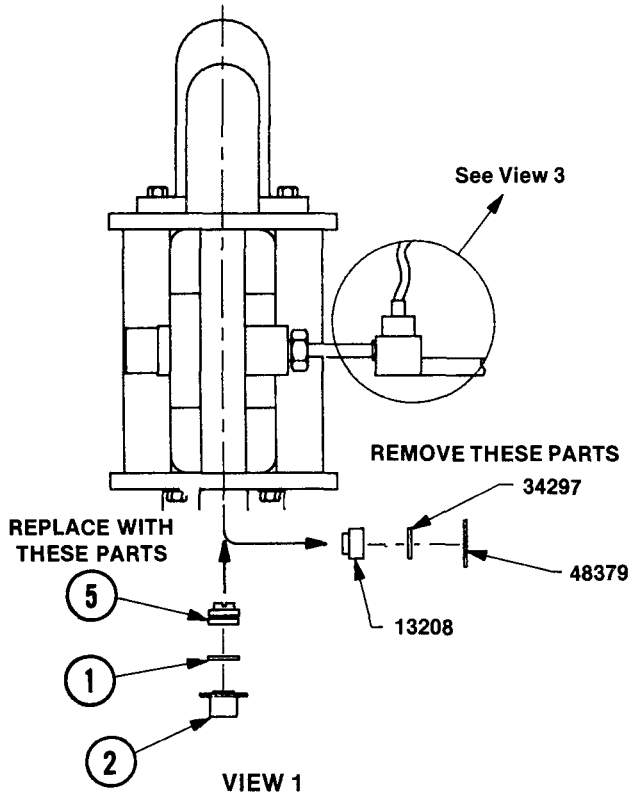
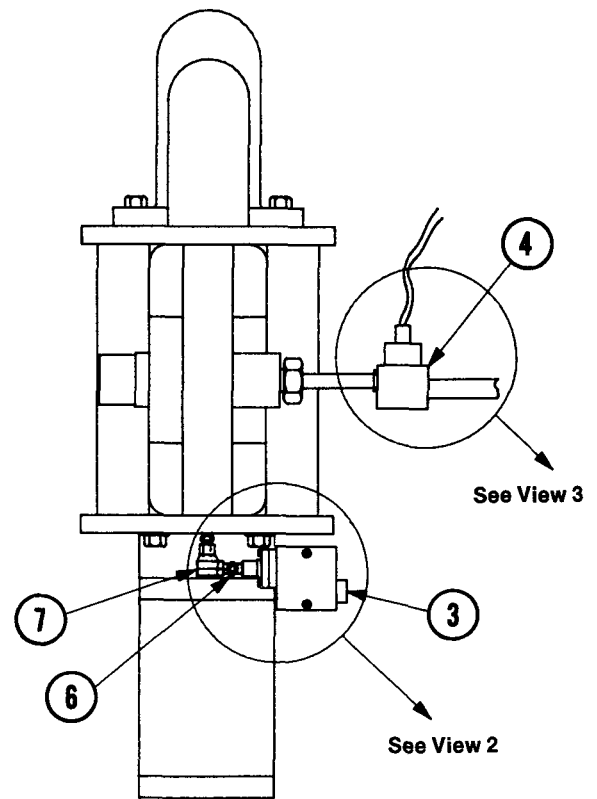

SPECIFICATIONS

Operating Pressure Range PSIG (BAR)	Min. I.D. of Air Supply Hose	Recommended Max. Speed to Control CPM	Pressure Switch Adjustment Range: PSIG (BAR)	Operating Temperature Range °F (°C)
30-100 (2-7)	Refer to Airmotor Manual	75	0-90 (0-6)	-30 to +200 (-34 to +93)