

FOR USE ON THE FOLLOWING POWER-MASTER III PUMP TUBES

SLEEVE NO.	86214	86215	86216	86217	86218	86238	86240	86241
IDENTIFICATION LETTER*	A	B	E	F	H	N	C	D
PUMP TUBES USED ON	84981, 84982 84983, 84984 84985, 84986	84997 84998	84993 84994	84995 84996	84991 84992	85201 85202	84978 84979	84976 84977

* Sleeves are stamped with a letter for identification.

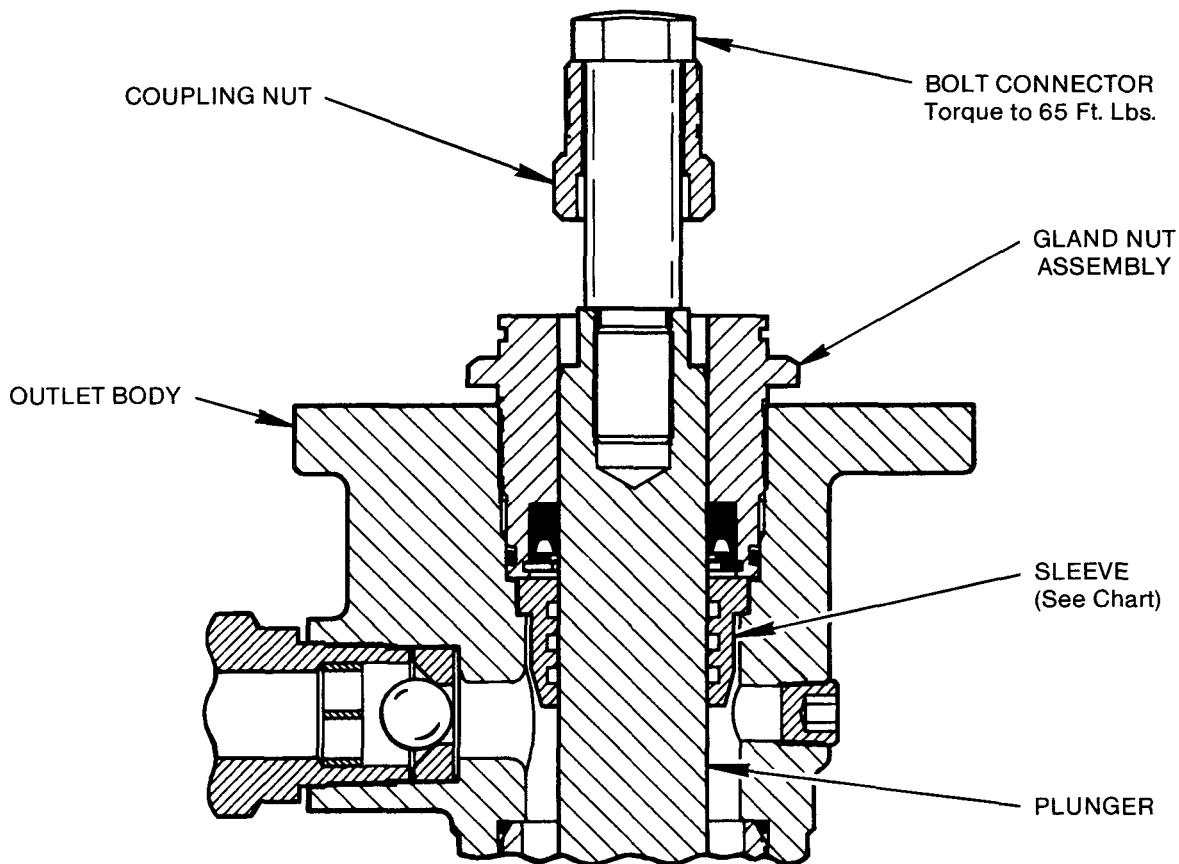

DESCRIPTION

The Gland Protection Sleeve** is designed to reduce the pressure fluctuation seen by the gland seal during a stroke changeover. The sleeve will prolong seal life and reduce gland leakage.

** U.S. Patent No. 4,976,192

ASSEMBLY PROCEDURE

- 1) Remove bolt connector, along with coupling nut.
- 2) Remove gland nut assembly.
- 3) Slide sleeve onto plunger and into outlet body. Sleeve must be seated as shown.
- 4) Replace gland nut assembly.
- 5) Replace bolt connector and coupling nut. Torque bolt connector to 65 Ft. Lbs.