

USED ON 1716, 1719 PUMP HOISTS AND 1735, 1736, 1737, 1704, 83274 PRESSURE PRIMERS
84141 INSTALLED ON 1716 AND 1719 PUMP HOISTS

Assembly is fastened to the adapter on the support tube assembly with the two 50055 bolts and 51001 nuts.

Kit parts not used on this installation:

10461, 66649, 68433, 68495, 68906, 82238-84, 82504

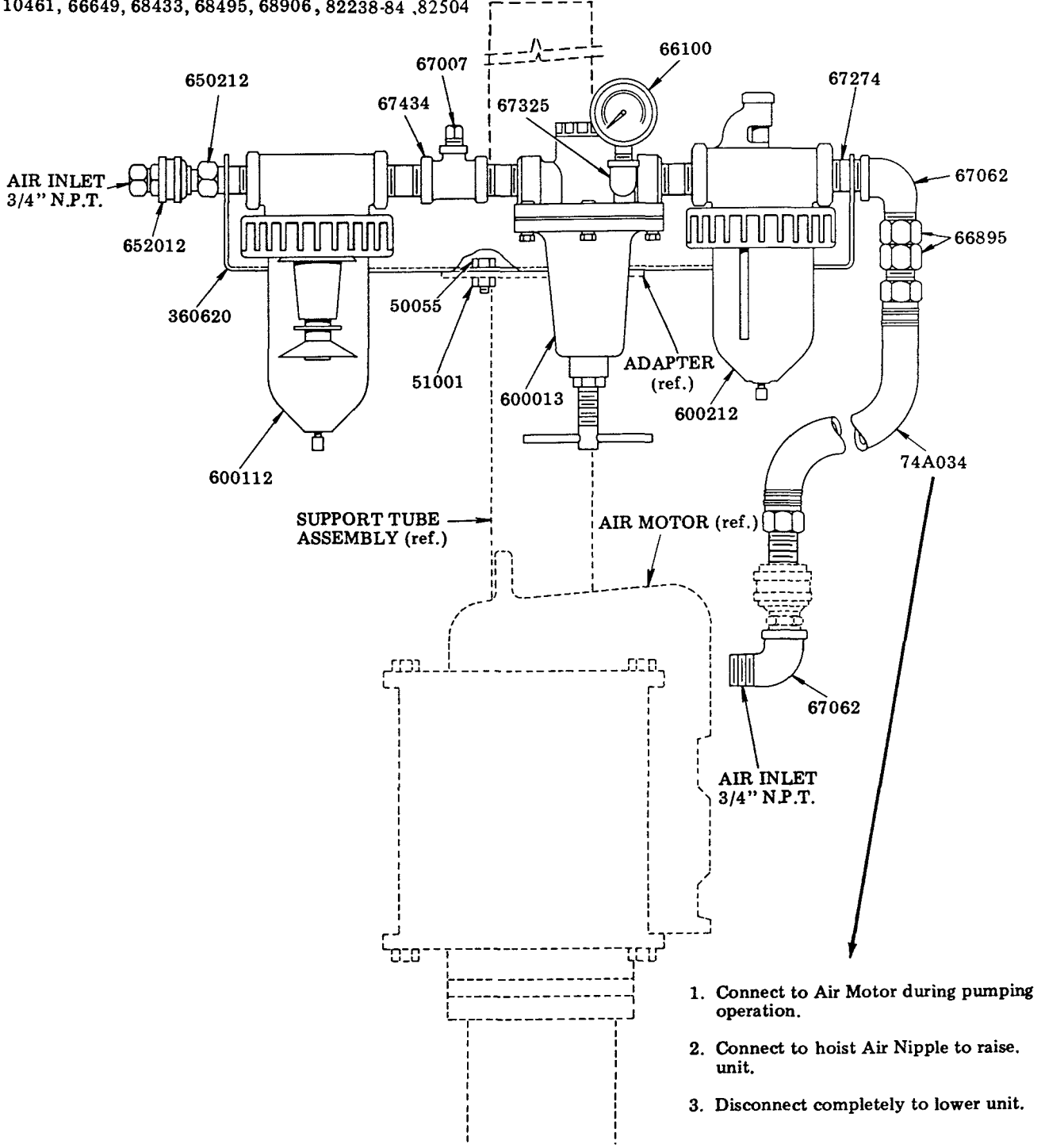

84141 INSTALLED ON 1735, 1736 OR 1737 PRESSURE PRIMER

Assembly is fastened to the top channel of the pressure primer with the two 50075 screws which are part of the Pressure Primer.

Kit parts not used on this installation:
50055, 51001, 67007, 82504.

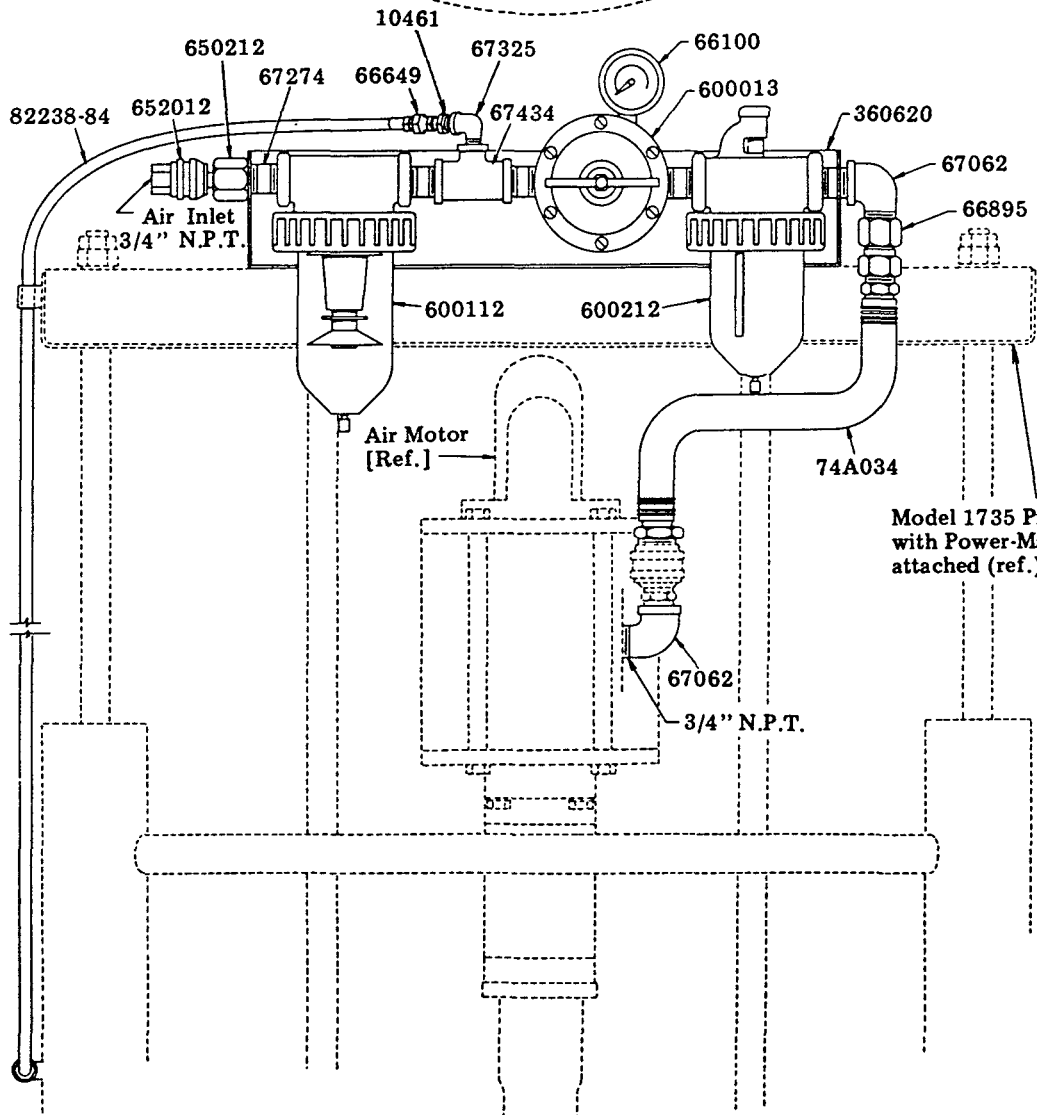
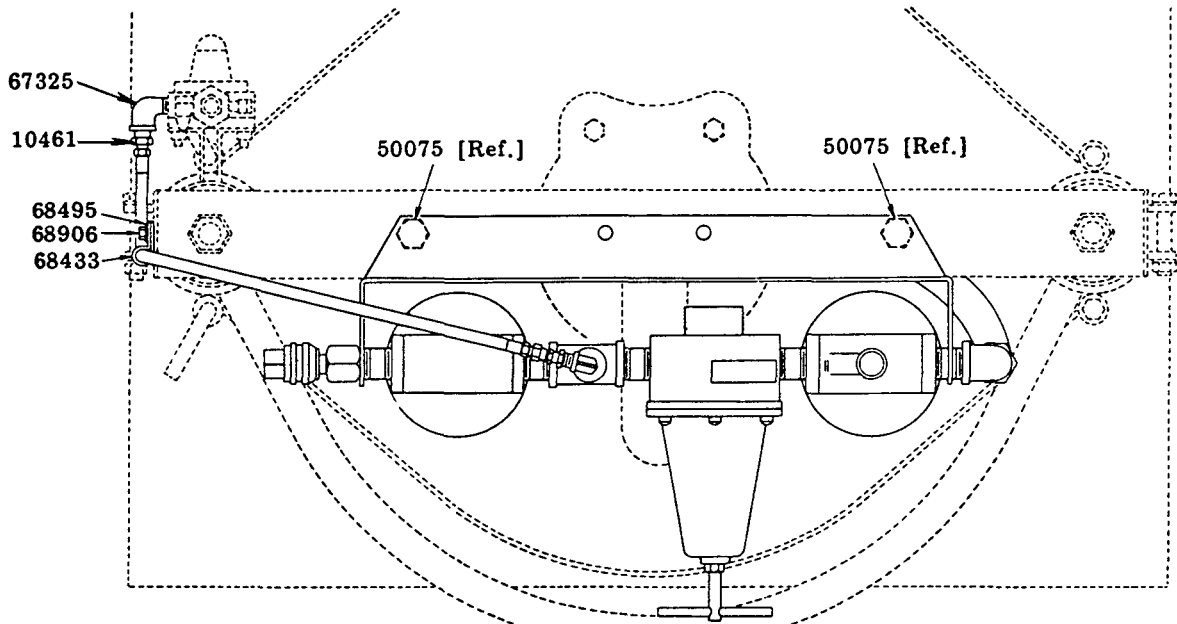

84141 INSTALLED ON 1704 AND 83274 PRESSURE PRIMER

Assembly is fastened to the two tie rod ends of the pressure primer air cylinder with two 51001 nuts.

Kit parts not used on this installation:
50055, 67007, 68433, 68495, 68906

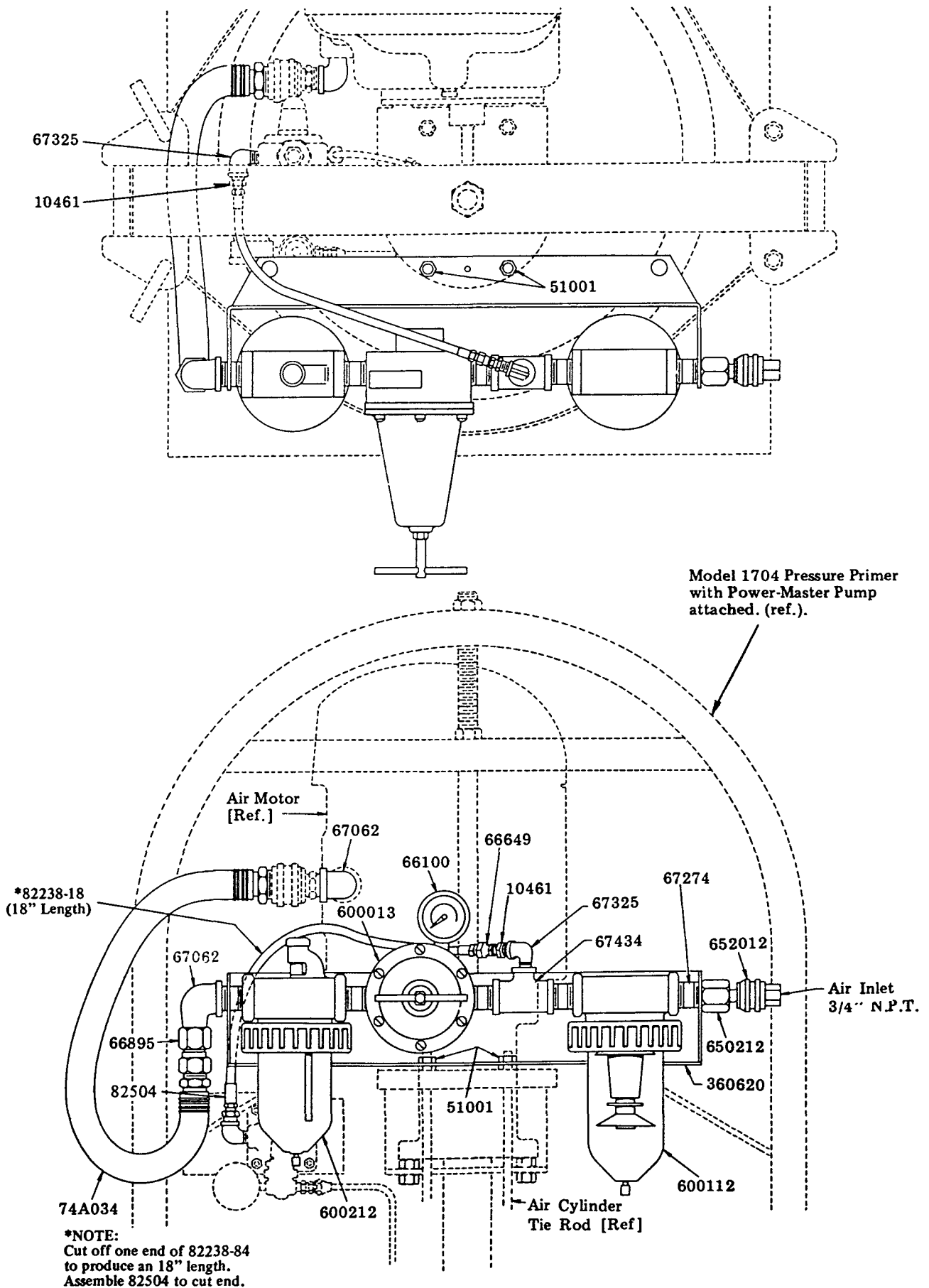

SERVICE PARTS

PART NO.	QUAN.	DESCRIPTION
10461	2	Bushing
50055	2	Screw
51001	2	Nut
66100	1	Pressure Gauge
66649	1	Adapter Union
66895	1	Adapter Union
67007	1	Pipe Plug
67062	2	Straight Elbow
67274	5	Nipple
67325	2	Straight Elbow
67434	1	Tee
68433	1	Tube Clamp
68495	1	Lockwasher
68906	1	Screw
74A034	1	Hose Assembly
82238-84	1	Hose Assembly
82504	1	Hose Coupling Assembly
360620	1	Bracket
600013	1	Air Regulator
600112	1	Air Filter
600212	1	Air Lubricator
650212	1	Air Nipple
652012	1	Socket Assembly

RETAIN THIS INFORMATION FOR FUTURE REFERENCE

When ordering replacement parts, list: Part Number, Description, Model Number, and Series Letter.

LINCOLN provides a Distributor Network that stocks equipment and replacement parts.

A list of Authorized Service Departments will be furnished upon request.