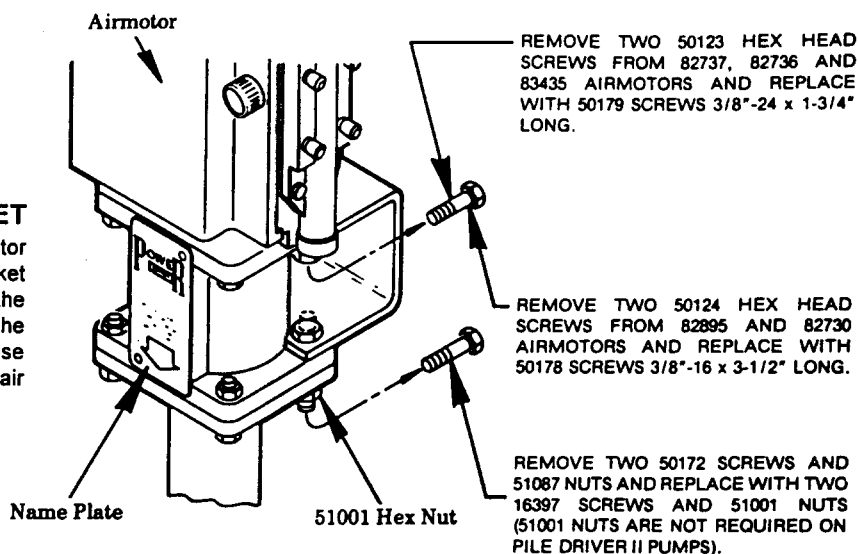

**Included With Models 1716 and 1719 Hoists
For 1900 Series Power Master and
2200 Series Pile Driver II Pumps****ASSEMBLY INSTRUCTIONS**

Mount bracket part number 84391 to pressure primer's support casting per illustration that shows the pump tube you will be using. See back page.

INSTALL PUMP TO MOUNTING BRACKET

Remove the four hex head screws from the side of the air motor opposite the name plate. Place the pump mounting bracket between the flanges of the air motor support casting. Using the screws included with hoist, fasten the mounting bracket to the air motor. Ten 48019 washers are included as shims for use between the mounting bracket and bottom flange of the air motor support casting.

**SERVICE PARTS**

PARTS	QTY	DESCRIPTION
16397	2	Hex, screw
48019	10	Washer
51001	2	Hex, nut
50178	2	Hex, screw
50179	2	Hex, screw

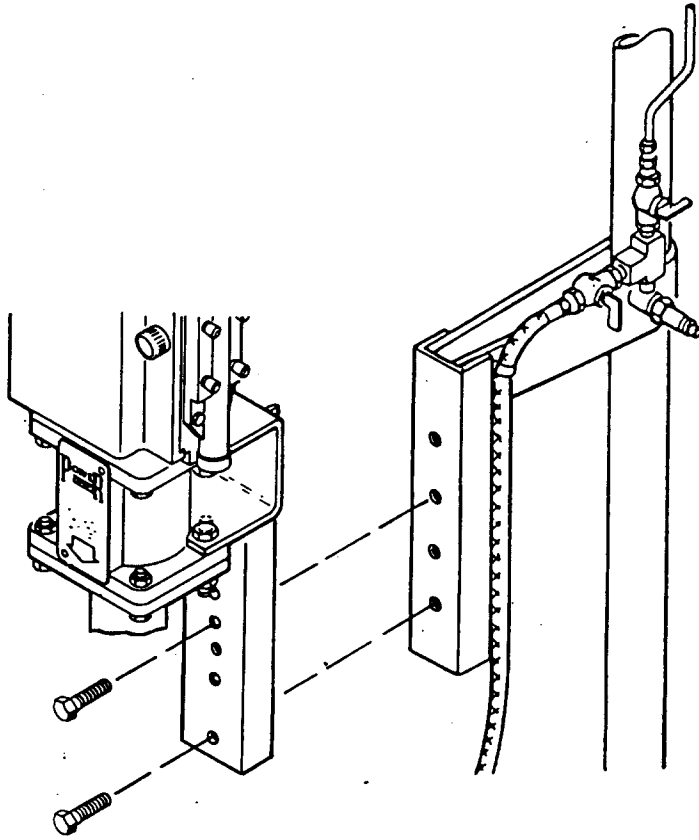

**POWER MASTER
SERIES 1900 PUMPS**

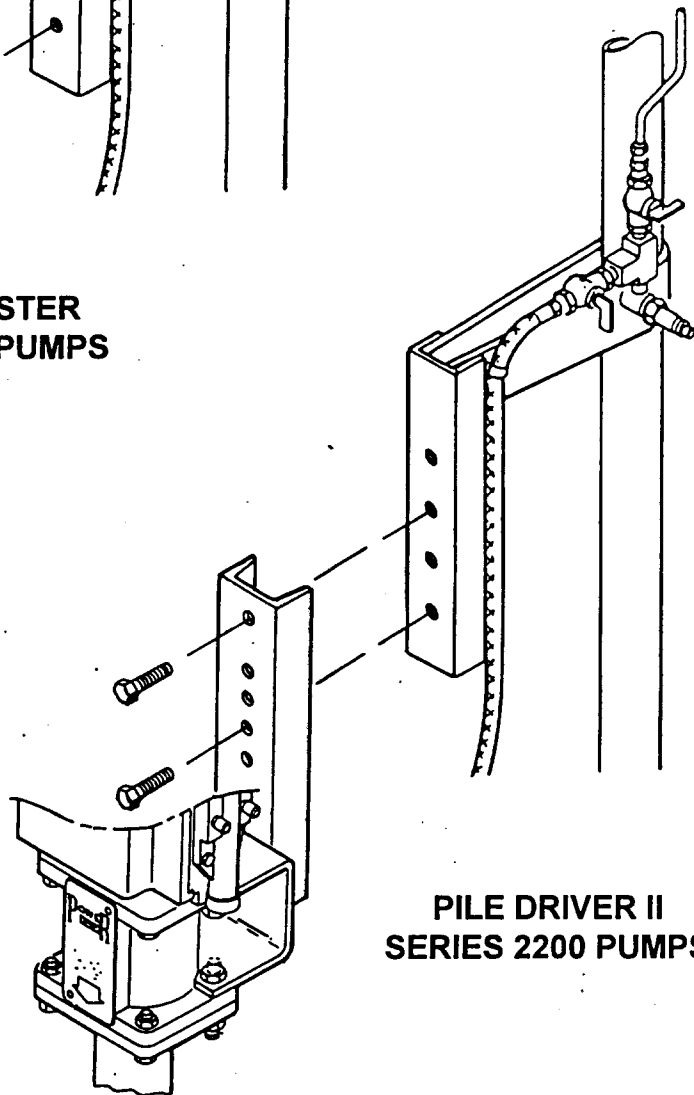

**PILE DRIVER II
SERIES 2200 PUMPS**

RETAIN THIS INFORMATION FOR FUTURE REFERENCE

When ordering replacement parts, list Part Number, Description, Model Number and Series Letter.

LINCOLN provides a Distributor Network that stocks equipment and replacement parts.