

**Included With Model 1718 Pressure Primer  
For 2200 Series Pile Driver Pumps**

**ASSEMBLY INSTRUCTIONS**

Mount bracket part number 84392 to pressure primer's support casting per illustration below.

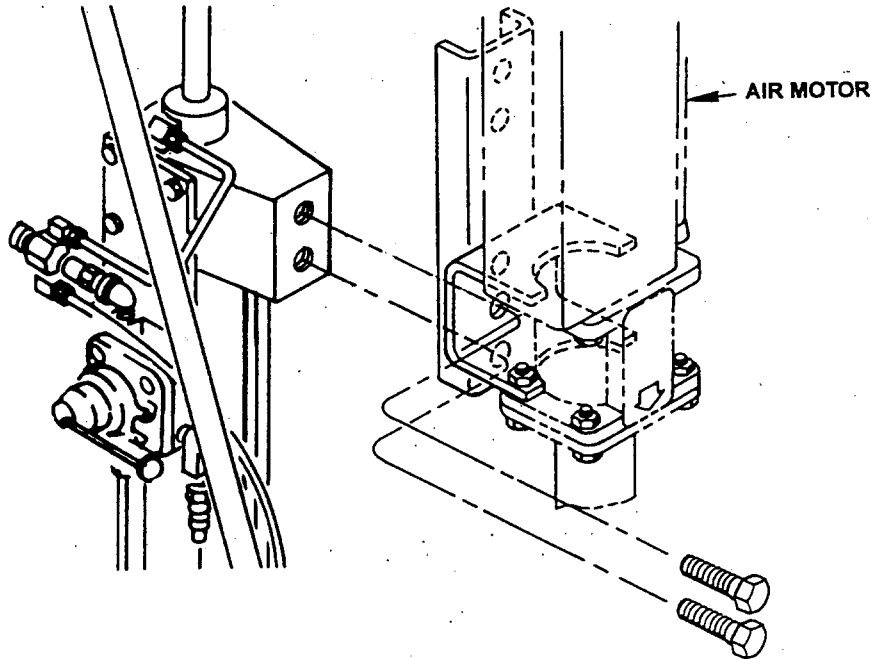

**INSTALL PUMP TO MOUNTING BRACKET**

Remove the four hex head screws from the side of the air motor opposite the name plate. Place the pump mounting bracket between the flanges of the air motor support casting. Using the screws included with hoist, fasten the mounting bracket to the air motor. Ten 48019 washers are included as shims for use between the mounting bracket and bottom flange of the air motor support casting.

**SERVICE PARTS**

PARTS	QTY	DESCRIPTION
16397	2	Hex, screw
48019	10	Washer
51001	2	Hex, nut
50178	2	Hex, screw
50179	2	Hex, screw

