

**USED ON 1716, 1719 PUMP HOISTS
AND 1735, 1736, 1704, 83274
PRESSURE PRIMERS**

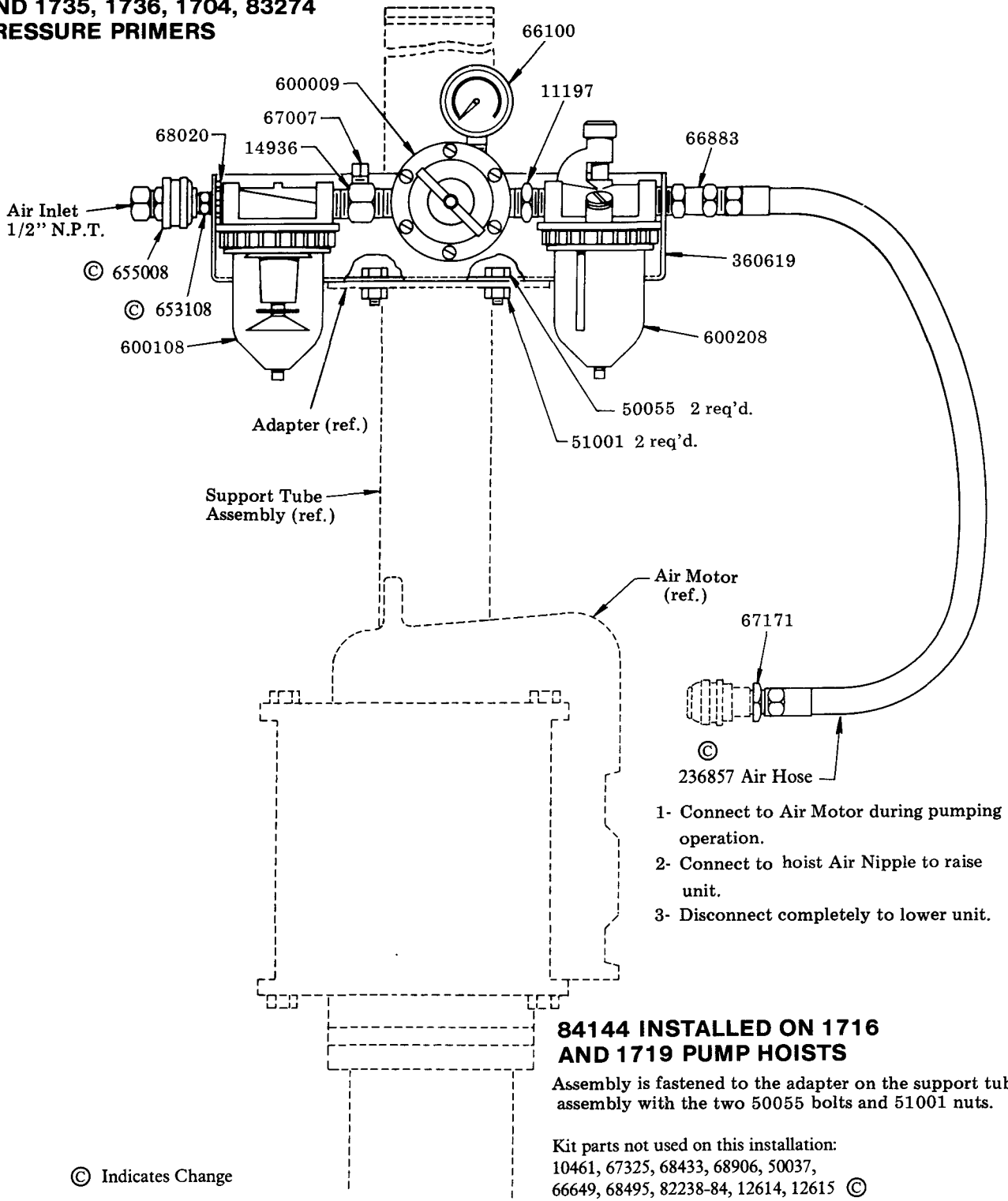

84144 INSTALLED ON 1735 OR 1736 PRESSURE PRIMER

Assembly is fastened to the top channel of the pressure primer with the 50037 screw and one 50075 screw which is part of the Pressure Primer.

Kit parts not used on this installation:
50055, 51001, 67007, 82504

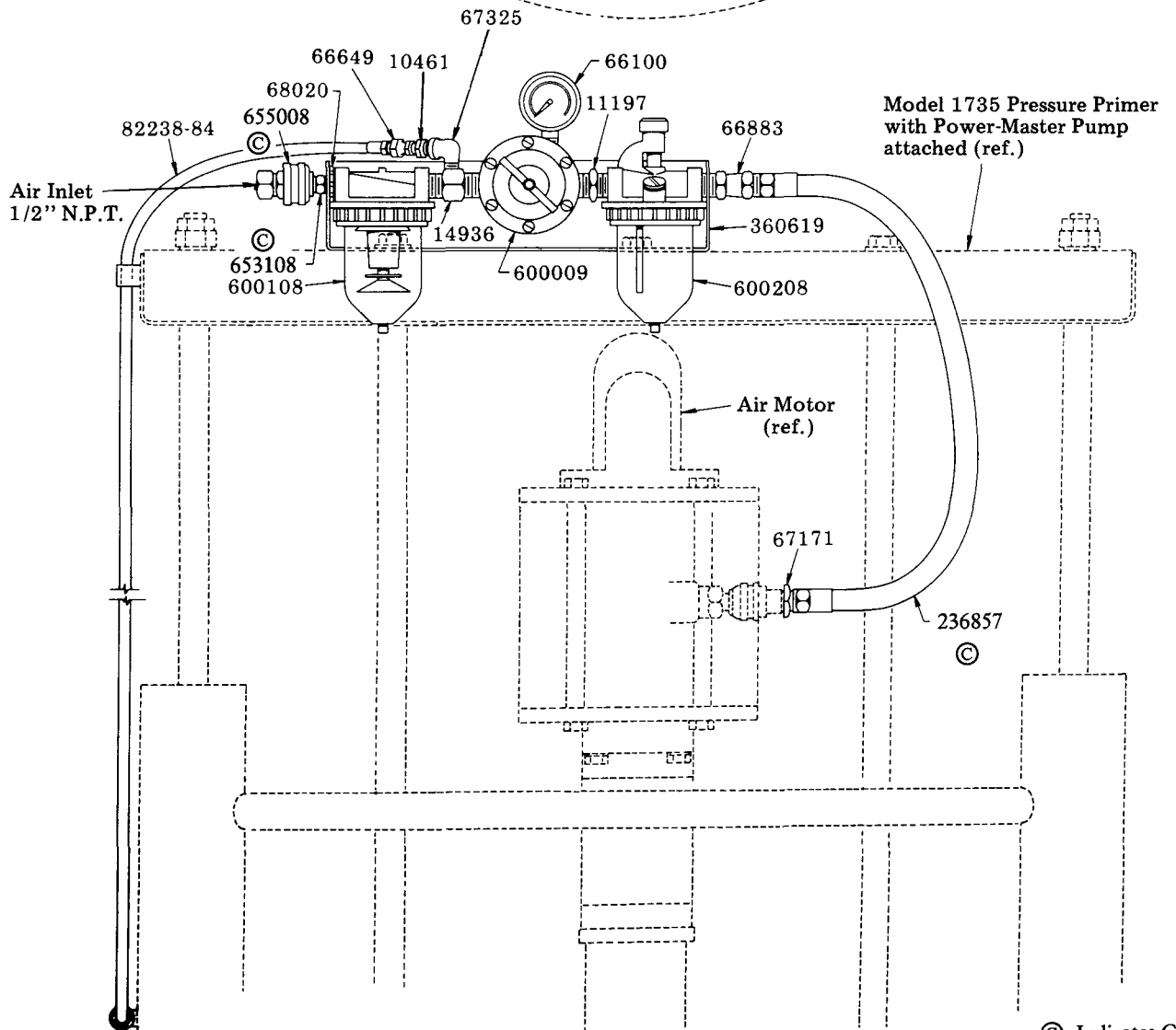
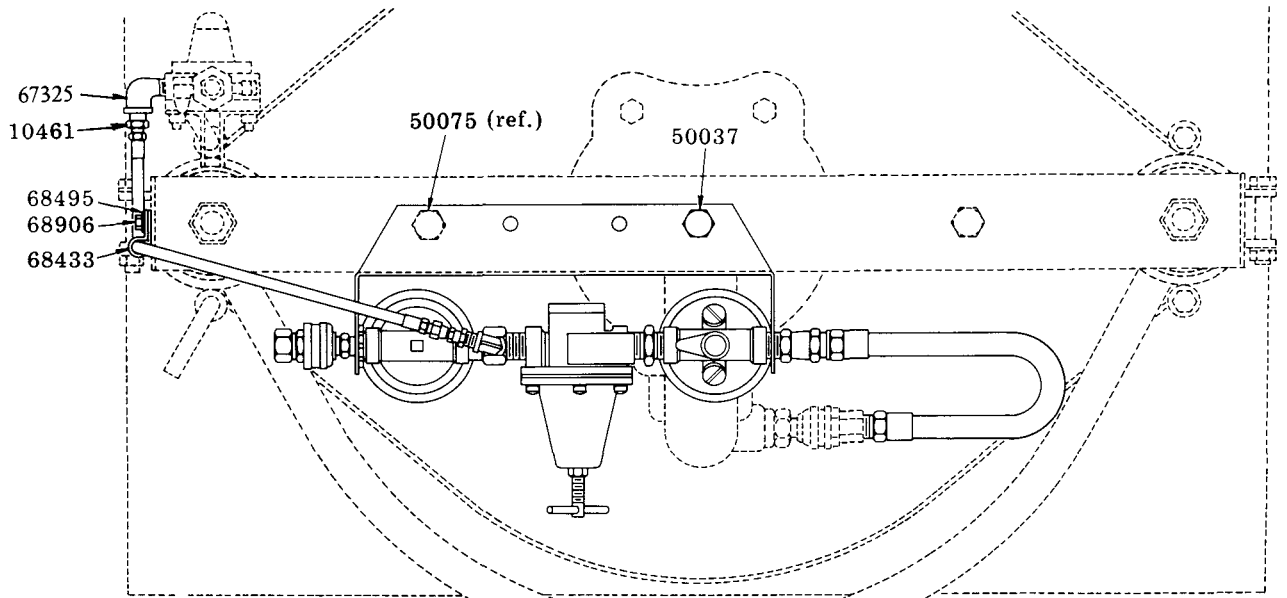

84144 INSTALLED ON 1704 AND 83274 PRESSURE PRIMER

Assembly is fastened to the two tie rod ends of the pressure primer air cylinder with two 51001 nuts.

Kit parts not used on this installation:
50037, 50055, 67007, 68433, 68495, 68906.

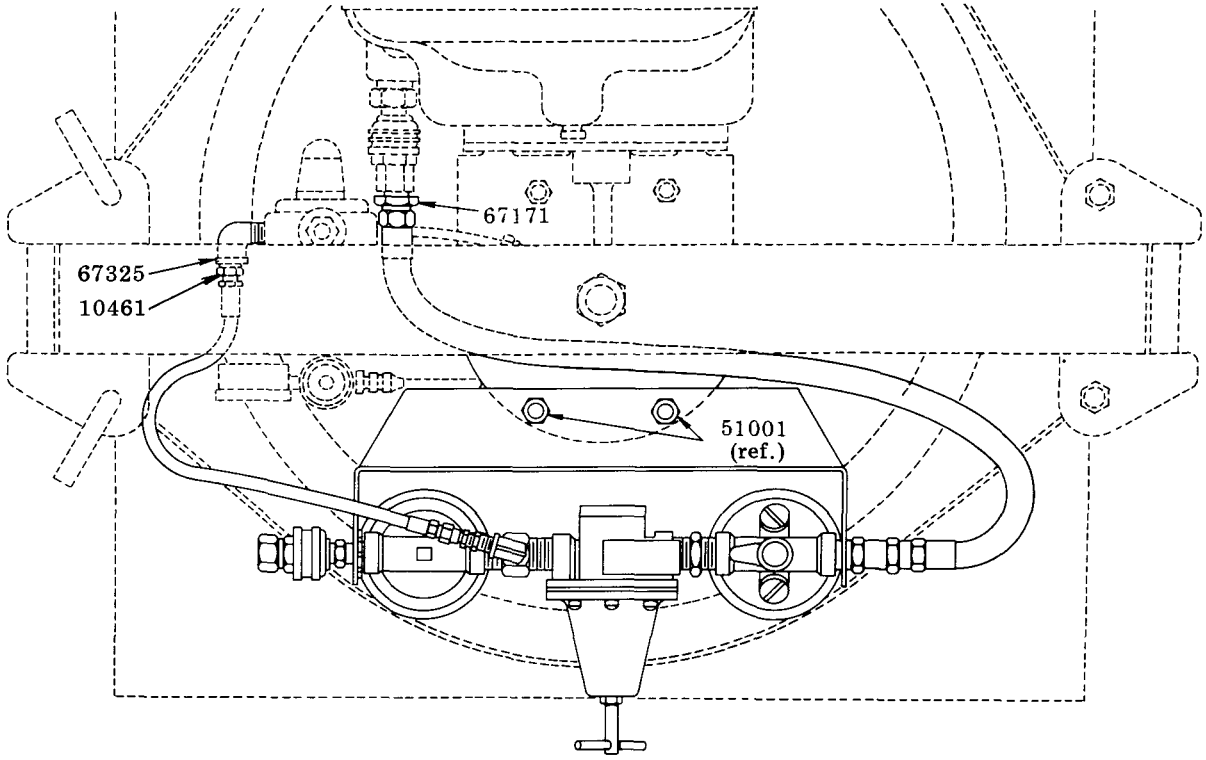

Model 1704 Pressure Primer with Power-Master Pump attached (ref.)

*NOTE:
Cut off one end of 82238-84 to produce an 18" length and assemble 12614 & 12615 to cut off end.

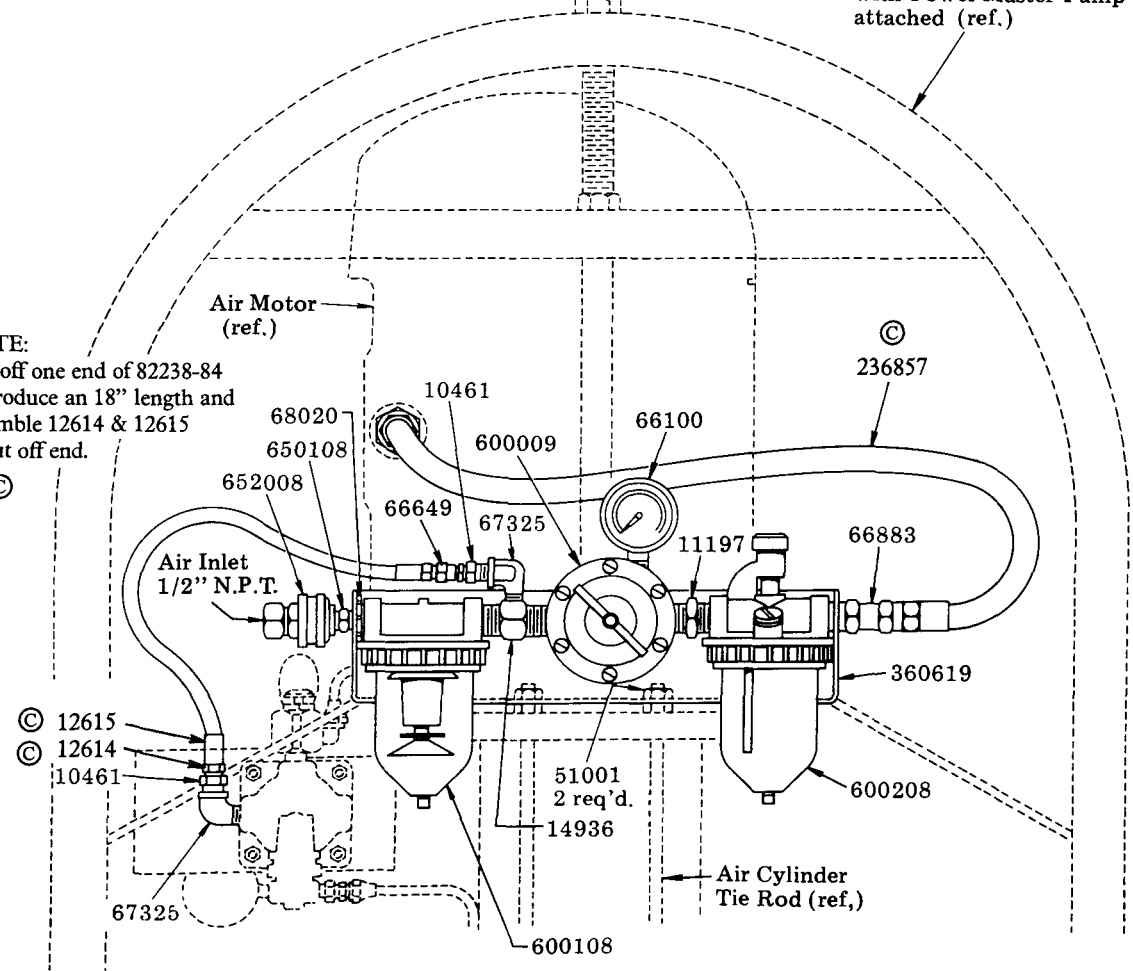

- © 12615
- © 12614
- 10461

SERVICE PARTS

Part	Qty.	Description
10461	2	Bushing
11197	1	Nipple
12614	1	Hose stud
12615	1	Coupling nut
14936	1	Tee
50037	1	Screw
50055	2	Bolt
51001	2	Nut
66100	1	Pressure gauge
66649	1	Adapter union
66883	1	Adapter union
67007	1	1/4" pipe plug
67171	1	Bushing
67325	2	1/4" street elbow
68020	1	Locknut
68433	1	Tube clamp
68495	1	Lockwasher
68906	1	Self-tapping screw
82238-84	1	Air hose
236857	1	Air hose
360619	1	Bracket
600009	1	Regulator
600108	1	Air filter
600208	1	Air lubricator
650108	1	Plug
652008	1	Socket assembly

RETAIN THIS INFORMATION FOR FUTURE REFERENCE

When ordering replacement parts, list: Part Number, Description, Model Number, and Series Letter.

LINCOLN provides a Distributor Network that stocks equipment and replacement parts.