

MCLP PUMP HEADS

7 MM & 11 MM PISTONS

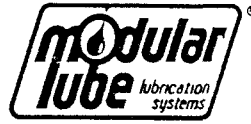

Models 130305

130306

Series "A"

The MCLP Pump Head is mounted to an MCLP Gear Box. By the action of a cam in the gear box, the pump plunger is pushed upward on the delivery stroke and returned to priming position by the plunger return spring.

The pump head requires a filtered oil supply by either gravity or under slight head pressure. Recommended filtration; 10 micron 70237 Filter. Lube inlet is located on either side of pump (3/8" NPTF). One inlet is plugged.

The MCLP Pump Head is available with 7mm and 11mm pistons. An adjustment screw in the top of the pump allows for variations in the quantity of oil delivered.

Output is determined by multiplying:
 Input Speed x Gear Ratio x Constant = PPD (Pints/Day)

EXAMPLE:

- Input Speed - 300 rpm
- Gear Ratio - 5.6:1
- Output Constant (11mm Pump) - .309 Min., 1.645 Max.

$$300 \times 1/5.6 \times .309 = 16.6 \text{ PPD Min.}$$

$$300 \times 1/5.6 \times 1.645 = 88.1 \text{ PPD Max.}$$

An anchor cross is located on the side of the MCLP Pump Head and includes the following:

- Purge port with check valve for priming the system
- Two Lube Outlets (1/4" NPTF)
- Plugged outlet for pressure gauge location (1/4" NPTF)
- Rupture indicator to atmosphere

	130305 7mm Pump Head Assembly	130306 11mm Pump Head Assembly
*Min. Output Constant (Adjusted one turn out.)	.100	.309
*Max. Output Constant (Adjusted five turns out.)	.758	1.645
Max. Inlet Pressure	50 psi	25 psi
Max. Working Pressure	6000 psi	3500 psi
Max. Speed	75 Pump Cycles Per Minute @ Max. Pressure. Consult factory for pump speed above 75 cycles per minute.	

*When using a double lobe cam multiply constant by 2.

MCLP REPLACEMENT PUMP HEAD ASSEMBLY

	MCLP Replacement Pump Head Assembly	MCLP Pump Head Assembly
7mm	130305-1	130305
11mm	130306-1	130306

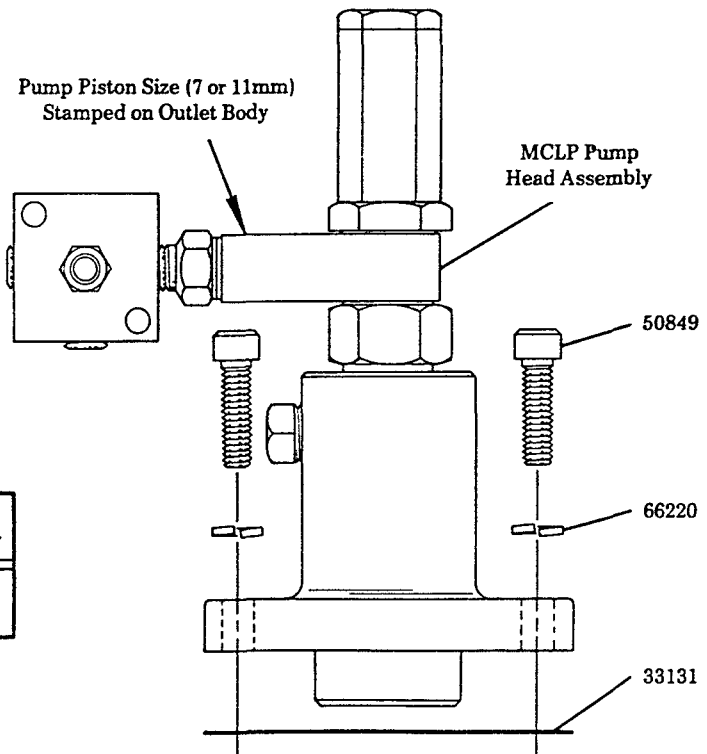

LINCOLN, One Lincoln Way
 St. Louis, Missouri 63120-1578
 (314) 679-4200 Customer Service, (314) 679-4300

SECTION - M1
 PAGE - 10

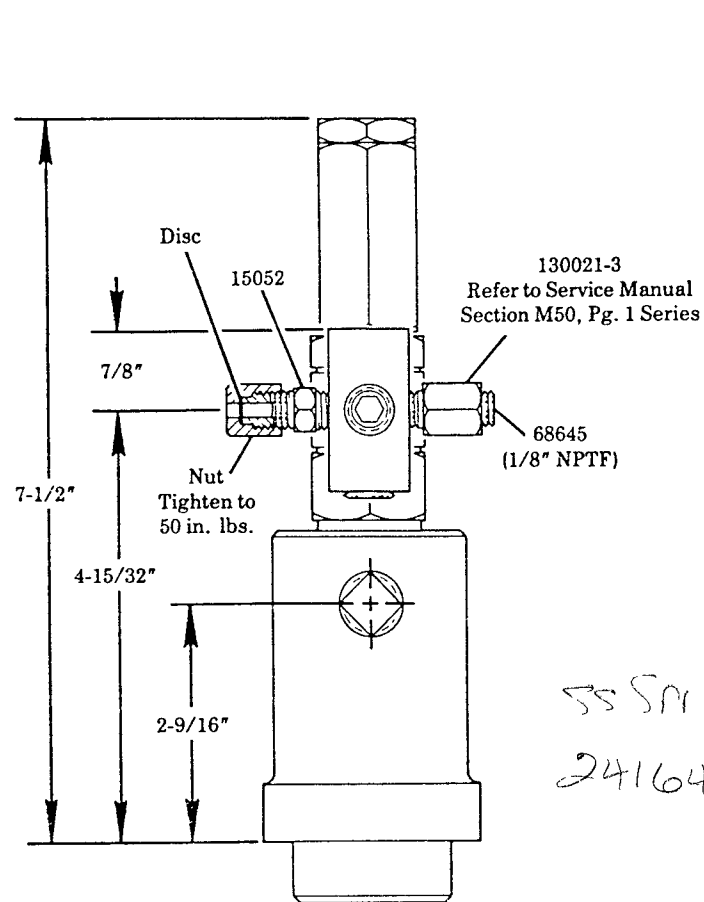

SS 5000 +
241645

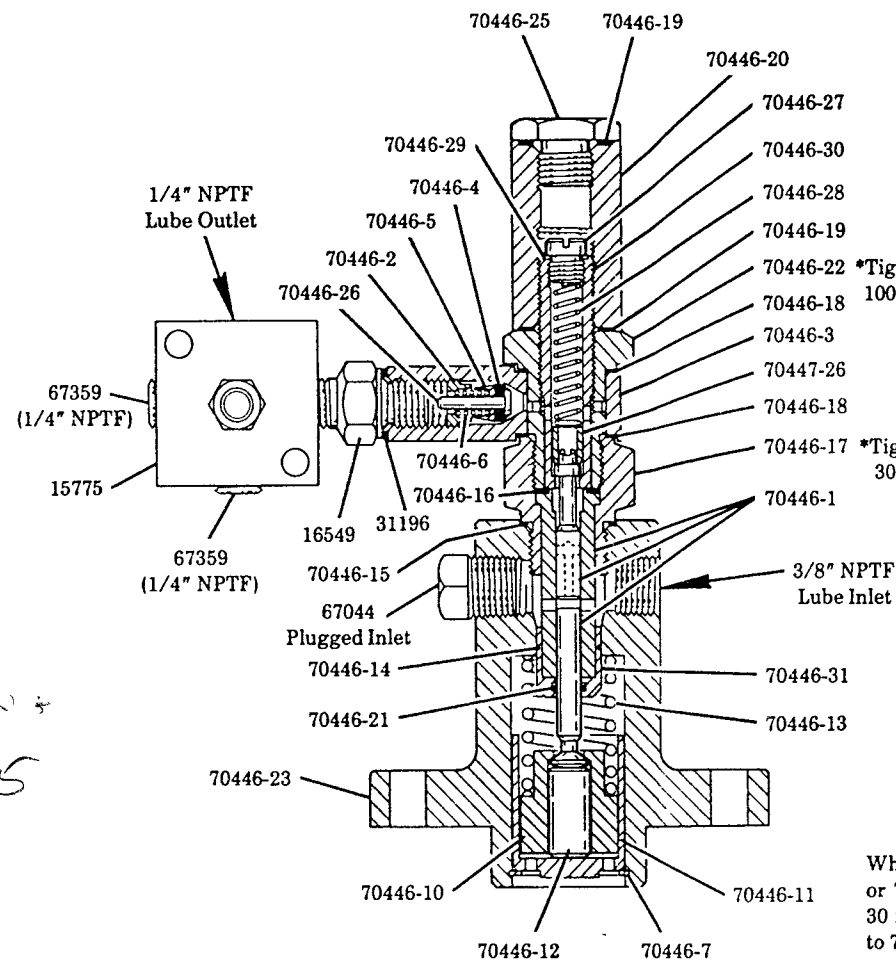

**MODEL 130305
7MM PUMP HEAD ASSEMBLY**

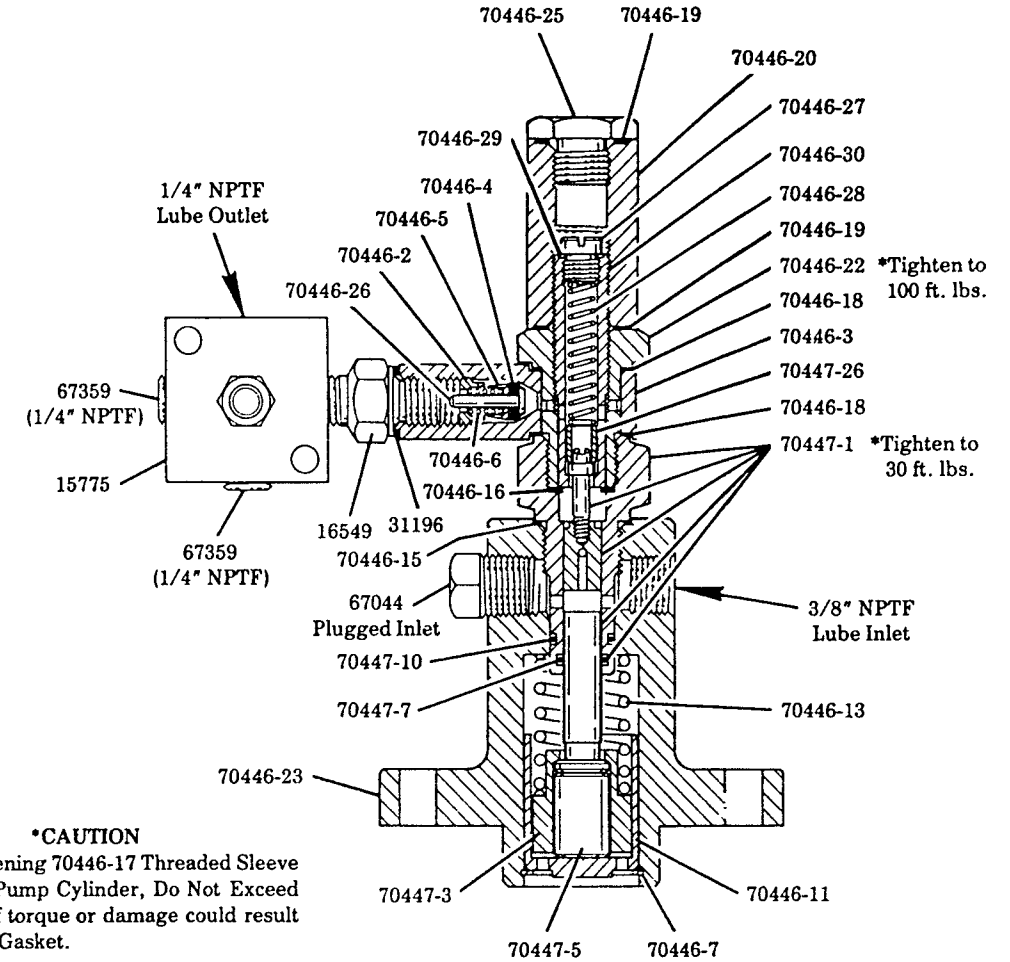

**MODEL 130306
11MM PUMP HEAD ASSEMBLY**

***CAUTION**
When tightening 70446-17 Threaded Sleeve or 70447-1 Pump Cylinder, Do Not Exceed 30 ft. lbs. of torque or damage could result to 70446-15 Gasket.

When tightening 70446-22 Threaded Bushing to 100 ft. lbs. 70446-17 or 70447-1 MUST be held with wrench so as not to exceed 30 ft. lbs. of torque between these parts and 70446-23 Pump Body.

MODEL	Nut	Disc (6 included)	Relief Pressure
130305 7mm Pump Head Assembly	15055	69813-14 (Orange)	5500 psi
130306 11mm Pump Head Assembly	15054	69813-22 (Purple)	3250 psi

TO POSITION PUMP OUTLET

Pump can be mounted to gear box with outlet either to front or back. If any other outlet position is desired use the following procedure. Hold 70446-22 Threaded Bushing with wrench, loosen 70446-20 Adjustment Housing and remove. 70446-17 Threaded Sleeve (7mm) or 70447-1 Pump Cylinder (11mm) MUST be held with wrench while removing 70446-22 Bushing. Remove two 70446-18 Gaskets and replace with new gaskets. Replace 70446-22 Bushing loosely and position 70446-3 Outlet Body as desired. 70446-17 Sleeve (7mm) or 70447-1 Pump Cylinder (11mm) MUST be held with wrench while tightening 70446-22 Bushing to 100 ft. lbs. Replace 70446-20 Adjustment Housing and tighten while holding 70446-22 Bushing with wrench. For readjustment refer to output adjustment procedure.

OUTPUT ADJUSTMENT

Hold 70446-20 Adjustment Housing with wrench and remove 70446-2 Cap. Hold 70446-22 Threaded Bushing with wrench and loosen 70446-20 Adjustment Housing. Back adjustment housing off approximately six turns. Turn adjustment screw clockwise to the stop. Pump is now in zero output position. Back adjustment screw out desired number of turns, minimum output - 1 turn, maximum output - 5 turns. CAUTION: Do not back adjustment screw out more than 5 turns. Output changes approximately .0033 cu. in.

(7mm) or .0067 cu. in. (11mm) per turn. Pump is factory set at 4 turns or approximately .012 cu. in. (7mm) or .026 cu. in. (11mm) per stroke. Hold adjustment screw in position with screwdriver and tighten 70446-20 Adjustment Housing hand tight. Hold 70446-22 Bushing with wrench and tighten adjustment housing. Replace 70446-25 Cap and tighten while holding adjustment housing with wrench.

ASSEMBLY INSTRUCTIONS

If disassembly becomes necessary, pump MUST be reassembled using the following procedure. Insert 70446-17 Threaded Sleeve and attached parts (7mm) or 70447-1 Pump Cylinder (11mm) into 70446-23 Pump Body and tighten to 30 ft. lbs. CAUTION: Damage could result to 70446-15 Gasket if sleeve is tightened to more than 30 ft. lbs. Replace two 70446-18 Gaskets with two new gaskets and place 70446-3 Outlet Body in desired position. Insert 70446-22 Threaded Bushing and tighten down hand tight. Tighten bushing to 100 ft. lbs. while holding 70446-17 Threaded Sleeve (7mm) or 70447-1 Pump Cylinder (11mm) with wrench. Install adjustment screw assembly and turn down to stop. Assemble 70446-20 Adjustment Housing and two 70446-19 Gaskets to adjustment screw. Readjust output following output adjustment procedure. Insert 70446-13 Spring through bottom of pump body. Insert plunger, 70446-10 Guide Housing (7mm) or 70447-3 Guide Housing (11mm) and 70446-12 Spacer (7mm) or 70447-5 Spacer (11mm) into pump, holding spacer into guide housing with finger. Place 70446-11 Plunger Guide Cup into bottom of pump and replace 70446-7 Lock Ring.

SERVICE PARTS

PART	QUAN.	DESCRIPTION	PART	QUAN.	DESCRIPTION
15052	1	Connector	70446-16	1	Gasket
15775	1	Anchor cross	70446-17	1	Threaded sleeve
16549	1	Adapter	70446-18	2	Gasket
31196	1	Gasket	70446-19	2	Thread gasket
33131	1	Gasket	70446-20	1	Adjustment housing
50849	2	Bolt	70446-21	1	O-ring
66220	2	Lockwasher	70446-22	1	Threaded bushing
67044	1	Pipe plug	70446-23	1	Pump body
67359	2	Pipe plug	70446-25	1	Cap
68645	1	Pipe plug	70446-26	1	Valve pin
70446-1	1	Piston & body	70446-27	1	Plug
70446-2	1	Check retainer	70446-28	1	Spring
70446-3	1	Outlet body	70446-29	1	Gasket
70446-4	1	Check valve seal	70446-30	1	Spindle
70446-5	1	Check spring retainer	70446-31	1	Bushing
70446-6	1	Check spring	70447-1	1	Pump cylinder
70446-7	1	Lock ring	70447-3	1	Guide housing
70446-10	1	Guide housing	70447-5	1	Spacer
70446-11	1	Plunger guide cup	70447-7	1	O-ring
70446-12	1	Spacer	70447-10	1	O-ring
70446-13	1	Plunger return spring	70447-26	1	Spacer
70446-14	1	O-ring	130021-3	1	Check valve
70446-15	1	Gasket			

————— RETAIN THIS INFORMATION FOR FUTURE REFERENCE —————

When ordering replacement parts, list: Part Number, Description, Model Number, and Series Letter.

LINCOLN ST. LOUIS provides a Distributor Network that stocks equipment and replacement parts.