

Models 880550 , 880560  
**MODEL 55i LUBRICATOR PUMPS**  
Series "A"

Standard Vacuum Feed Pump  
Includes Viton Seals for Petroleum  
or Synthetic Lubricants.  
Max. Oil viscosity - 8000 SUS

MODEL 880550 1/4" PLUNGER: 6000 PSI MAX. PRESSURE.  
MODEL 880560 3/8" PLUNGER: 3500 PSI MAX. PRESSURE.

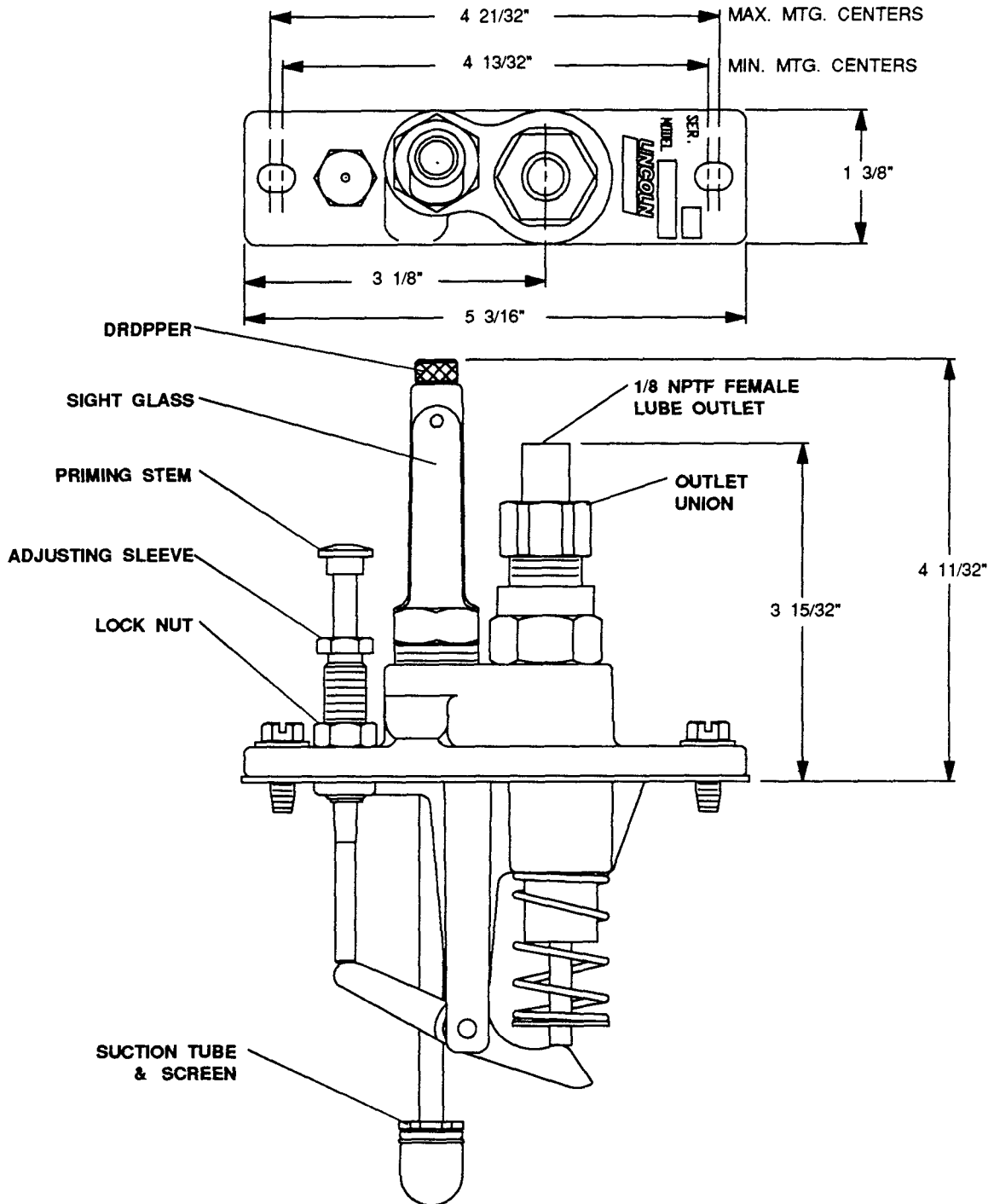

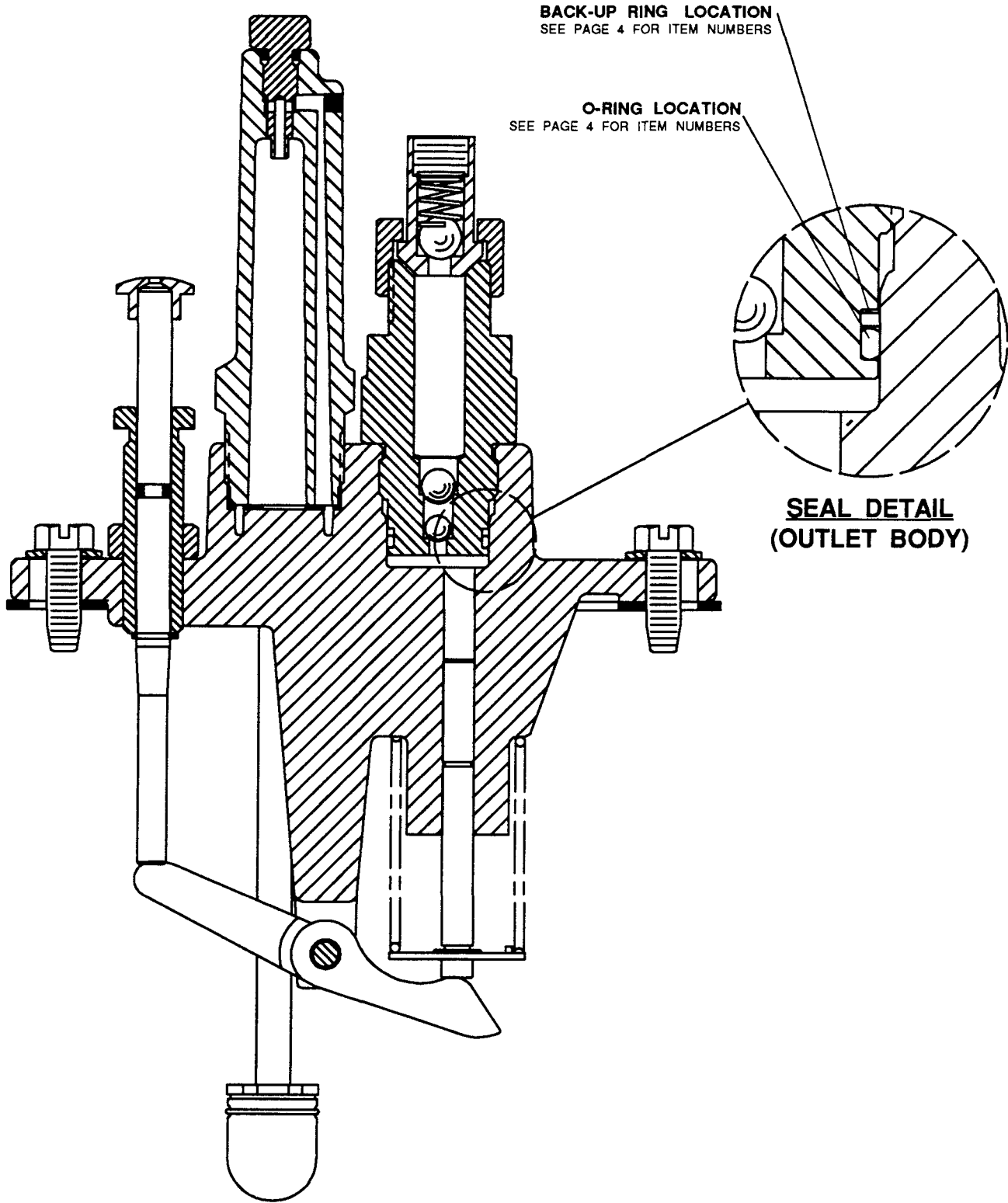

**PUMP ASSEMBLY CUTAWAY VIEW**

## PUMP DESCRIPTION

The Model 55i Lubricator Pump is an improved version of the previous Lincoln Model 55 Lubricator Pump. Pump performance and serviceability have been improved with the Model 55i. The pump has been simplified by reducing the part count. The number of seals have been reduced by creating a unit pump body and sight glass, thus reducing the number of service parts and possible leak problems.

## PUMP OPERATION

The pump is operated by a rotating cam against the pumps rocker arm, causing the pump's plunger to reciprocate within it's bore in the pump body.

The pump output is set by the adjusting sleeve on top of the pump body. The sleeve limits the stroke length of the pump plunger thus limiting the pump output. Full pump output may be obtained when the adjusting sleeve is fully extended out of the top of the pump body, allowing for full plunger stroke.

Maximum recommended oil viscosity is 8000 SUS.

## SUCTION STROKE

As the plunger moves downward, oil is drawn through the suction check and into the plunger bore from the small reservoir in the sight glass. Reducing the volume of oil in the sight glass creates a vacuum which draws oil from the lubricator reservoir, through the suction tube and into the outside passage in the sight glass. The oil will then enter the dropper and drip into the sight glass reservoir, replacing the oil removed by the suction stroke. The quantity of oil delivered may be determined by counting the drops of oil falling out of the dropper.

## DISCHARGE STROKE

As the plunger moves upward, oil is forced from the plunger bore through the outlet checks and into the lubrication point feedline. The suction check prevents any back flow of oil into the sight glass assembly and allows any oil that may bypass the plunger to be returned to the sight glass, area through a return passage.

## STARTING INSTRUCTIONS

- 1) Remove the dropper from the sight glass and fill approximately 1/3 full of oil.
- 2) Manually operate the pump with the priming stem until oil, without air bubbles, flows from pump outlet.
- 3) Connect the feedline to the pump outlet union and manually operate the pump with the priming stem until the feedline is filled.
- 4) Connect the feedline to the lubrication point. A feedline check valve at the lubrication point is recommended and is available as an accessory item.
- 5) Refill the sight glass to the 1/3 full level.
- 6) Refill the lubricator reservoir and adjust the pump output.

## SETTING PUMP OUTPUT

Count the number of drops falling through the sight glass in one minute. Set the adjusting sleeve to obtain the desired quantity and secure the setting with the locknut.

### **Conversion factors:**

1 drop = .002 cu. in.

500 drops = 1 cu. in.

## SIGHT GLASS:

The sight glass gives a visual indication of the condition of the oil flowing through the lubrication pump.

An increasing oil level indicates absorption of air in the sight glass by the oil passing through. Over fill eliminates visual metering of drops in the sight glass, but has no effect on pump operation.

A decreasing oil level indicates the vacuum in the sight glass is withdrawing entrained air from the oil passing through the sight glass, or a vacuum leak in the pump's inlet circuit. **If the decreasing oil level is allowed to continue, an airlock can result.**

Under normal conditions, the oil level will raise or fall until an equilibrium is reached, but may change from time to time as the condition of the oil changes. Regardless of the oil level, a continuing passage of the correct oil volume indicates that the pump is operating properly.

## AIRLOCK:

Airlocking occurs when air, instead of oil, enters the plunger bore and can not be compressed to a high enough pressure to be forced out of the pump against the feedline back pressure.

Airlocking is caused either by entrained air being separated from the oil by the vacuum in the sight glass, or by air entering the pump when the oil level in the lubricator reservoir is lower than the suction tube inlet. Severely agitated oils, such as oil supplied from a crankcase, will usually contain entrained air. An airlock can be easily detected since, when it occurs, no oil will be visible in the sight glass. If entrained air is found to be a problem, either a pressurized pump supply or a settling tank should be utilized.

An airlock can be eliminated by refilling the lubricator reservoir, and sight glass, loosening the outlet union at the pump outlet, and manually operating the pump with the priming stem until no air bubbles appear at the pump outlet. The airlock may reoccur if the cause is not found and eliminated.

## OVER FILL:

Over filling is caused by the oil absorbing the air in the sight glass as it passes through the pump.

This condition does not affect the operation of the pump except that the oil can not be observed coming out of the dropper due to the sight glass being filled with oil.

Normal sight glass operation can be restored by momentarily loosening the dropper at the top of the sight glass to break the vacuum within the sight glass. Do not leave the sight glass dropper open for very long as this will allow all of the oil in the sight glass to drain out possibly causing an airlock condition.

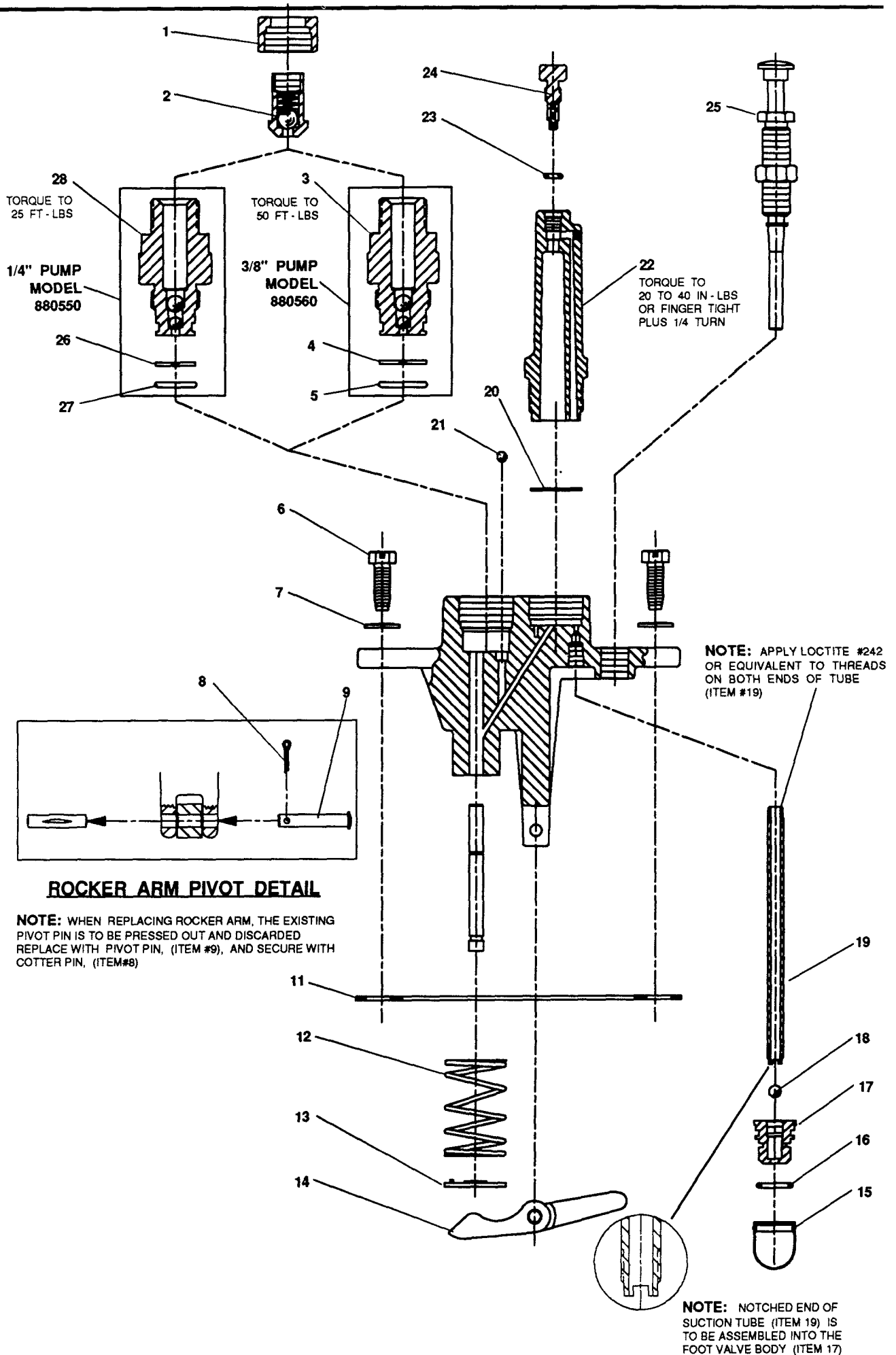

**NOTE:** SERVICE PARTS FOR MODELS 880550 AND 880560 ARE AVAILABLE ONLY IN THE SERVICE KITS LISTED BELOW. INDIVIDUAL SERVICE PARTS AND PARTS NOT LISTED BELOW ARE NOT AVAILABLE. QUANTITIES IN KITS ARE ONE EACH UNLESS OTHERWISE SPECIFIED.

**NOTE:** THE ILLUSTRATIONS ON THIS PAGE ARE SHOWN ACTUAL SIZE.

ITEM NO	DESCRIPTION
<b>69879 REPLACEMENT SCREEN ASSEMBLY</b>	
15	SCREEN ASSEMBLY
<b>250136 SUCTION TUBE</b>	
19	SUCTION TUBE
<b>250142 SIGHT GLASS REPLACEMENT KIT</b>	
20	SIGHT GLASS SEAL
22	SIGHT GLASS
23	O-RING
24	DROPPER
<b>250143 PUMP MOUNTING KIT</b>	
6	MOUNTING SCREW (2 SUPPLIED)
7	BELLEVILLE WASHER (2 SUPPLIED)
11	PUMP MOUNTING GASKET
<b>250144 PUMP SEAL KIT FOR MODEL 880560 (3/8" PUMP)</b>	
4	BACK-UP RING (OUTLET BODY)
5	O-RING (OUTLET BODY)
16	O-RING (SUCTION TUBE)
18	BALL (SUCTION TUBE)
20	SIGHT GLASS SEAL
21	BALL (INLET CHECK)
23	O-RING (DROPPER)
<b>250146 OUTLET UNION ASSEMBLY</b>	
1	UNION NUT (OUTLET)
2	SLEEVE ASSY (OUTLET)
<b>250166 OUTLET CHECK KIT FOR MODEL 880560 (3/8" PUMPS)</b>	
3	ADAPTER ASSEMBLY (WITH CHECK BALLS)
4	BACK-UP RING
5	O-RING
<b>250167 ROCKER ARM REPLACEMENT KIT</b>	
8	COTTER PIN
9	PIVOT PIN
12	SPRING (PLUNGER RETURN)
13	SPRING RETAINER
14	ROCKER ARM
<b>250169 PRIMING UNIT ASSEMBLY</b>	
25	PRIMING UNIT ASSEMBLY
<b>250171 REPLACEMENT DROPPER ASSY.</b>	
23	O-RING
24	DROPPER
<b>250172 PUMP SEAL KIT FOR MODEL 880550 (1/4" PUMP)</b>	
26	BACK-UP RING (OUTLET BODY)
27	O-RING (OUTLET BODY)
16	O-RING (SUCTION TUBE)
18	BALL (SUCTION TUBE)
20	SIGHT GLASS SEAL
21	BALL (INLET CHECK)
23	O-RING (DROPPER)
<b>250173 OUTLET CHECK KIT FOR MODEL 880550 (1/4" PUMPS)</b>	
26	BACK-UP RING
27	O-RING
28	ADAPTER ASSEMBLY (WITH CHECK BALLS)

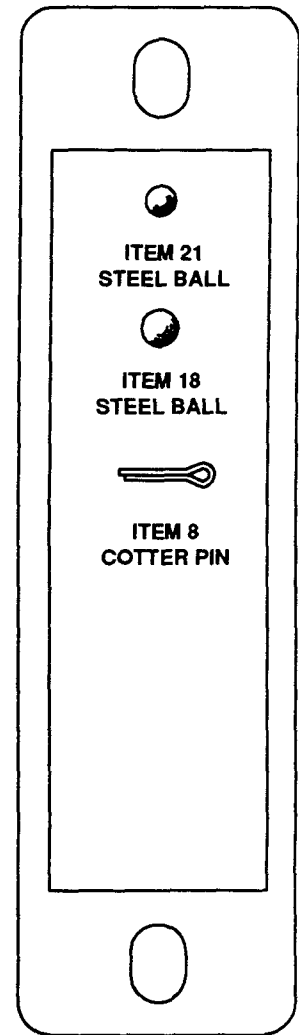
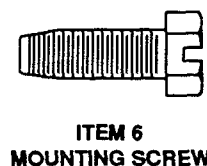
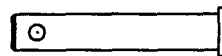

ITEM 11  
PUMP MOUNTING  
GASKET



---

# LUBRICATOR ACCESSORIES

## Lube Sentries

**Model 880447** Monitors camshaft rotation and reservoir oil level. See Service Manual Section M30, Page 10 Series

**Model 880456** Same as 880447 except with 1" short suction tube. See Service Manual Section M30, Page 10 Series.

## Oil Level Regulator

**Model 880496** Automatically fills lubricator reservoir. See Service Manual Section M30, Page 9 Series.

## Lubricator Flow Switches

**Note:** To be used with non-conductive fluids only.

**Caution:** Lubricator must be properly grounded.

**Model 880463** Used on individual Type 55 Lubricator pumps to monitor lubricant flow. See Service Manual Section M31, Page 9 Series.

**Model 880466** Same as 880463 except includes terminal for series wiring. See Service Manual Section M31, Page 9 Series.

## Armored Pump Sight Glass

**Model 250176** Armored sight glass kit with pyrex sight tube. Adapts the old Model 55 sight glass assembly to the new Model 55i pump assembly.

---

**— RETAIN THIS INFORMATION FOR FUTURE REFERENCE —**

When ordering replacement parts, list: Part Number, Description, Model Number, and Series Letter.  
LINCOLN provides a Distributor Network that stocks equipment and replacement parts.