

**Models 880551, 880552, & 880561**  
**MODEL 55i LUBRICATOR PUMPS**  
**Series "B"**

**Pressurized Inlet Pumps**  
(See Pump Specifications for Limitations.)

**MODEL 880551 & 880552 1/4" PLUNGER.**  
**MODEL 880561 3/8" PLUNGER.**

**Includes Viton Seals for Petroleum or Synthetic Lubricants.** **MODELS 880551 & 880561**

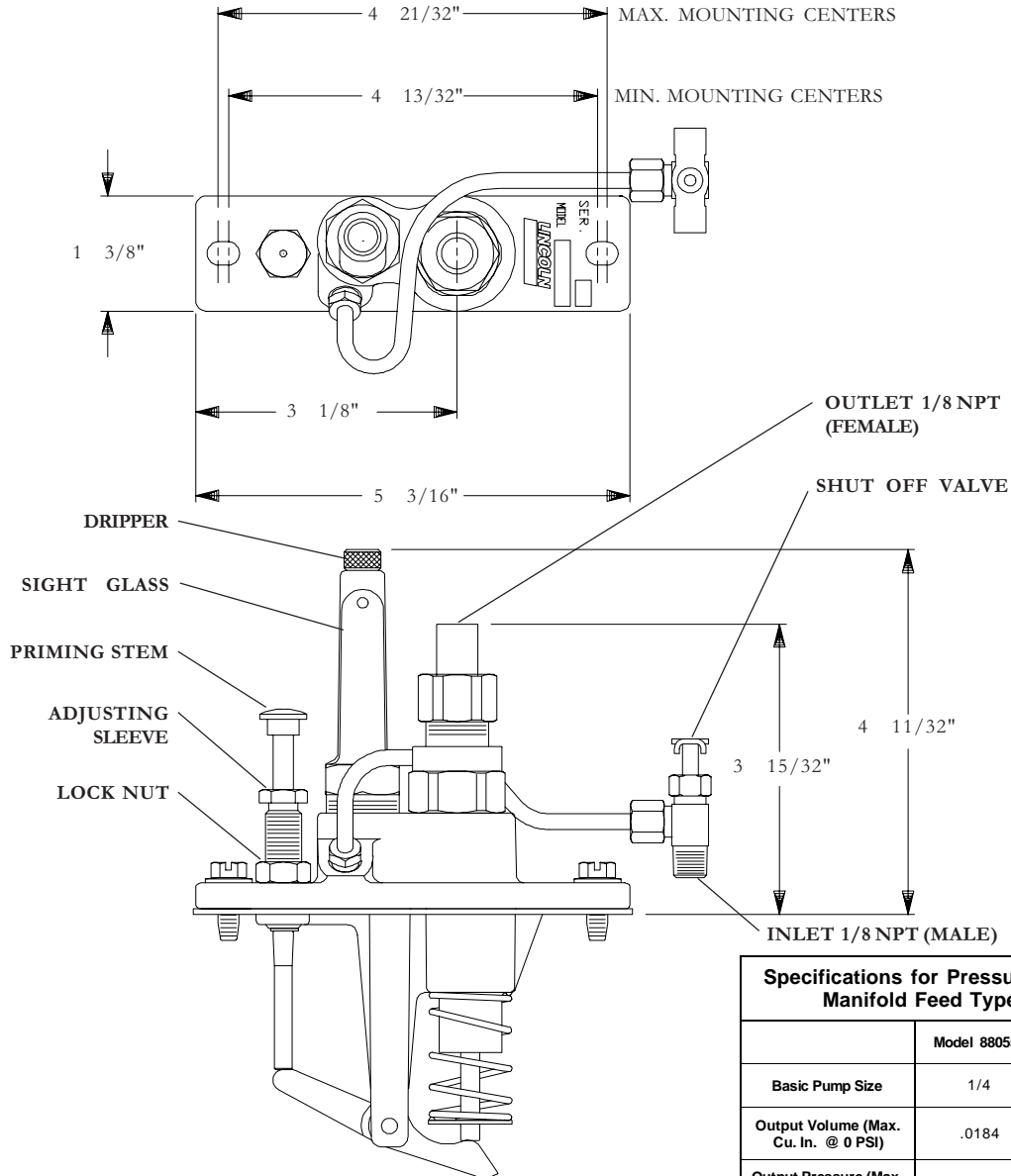

Specifications for Pressurized Suction, Manifold Feed Type Pumps		
	Model 880551	Model 880561
Basic Pump Size	1/4	3/8
Output Volume (Max. Cu. In. @ 0 PSI)	.0184	.0415
Output Pressure (Max. PSI)	6000	3500
Inlet Pressure * (Max. PSI)	100	100

\* Inlet pressure must be less than lowest system back pressure.

**MODEL 880552**  
**Pressurized Suction Type Pump**

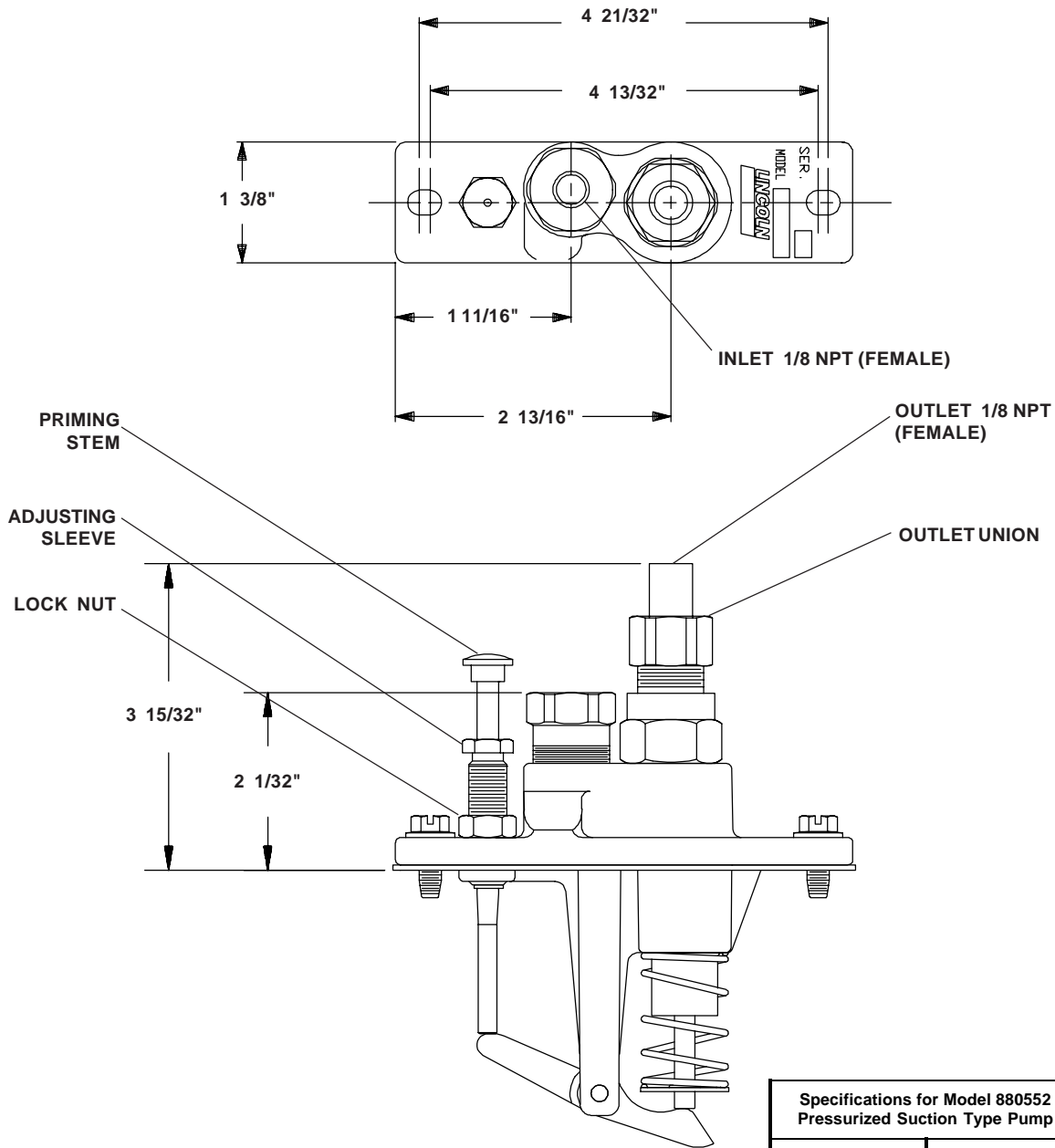

Specifications for Model 880552 Pressurized Suction Type Pump	
Basic Pump Size	1/4
Output Volume (Max. Cu. In. @ 0 PSI)	.0184
Output Pressure (Max. PSI)	6000
Inlet Pressure * (Max. PSI)	250

\* Inlet pressure must be less than lowest system back pressure.

**TYPICAL PUMP ASSEMBLY  
CUTAWAY VIEW  
(SIGHT GLASS SHOWN)**

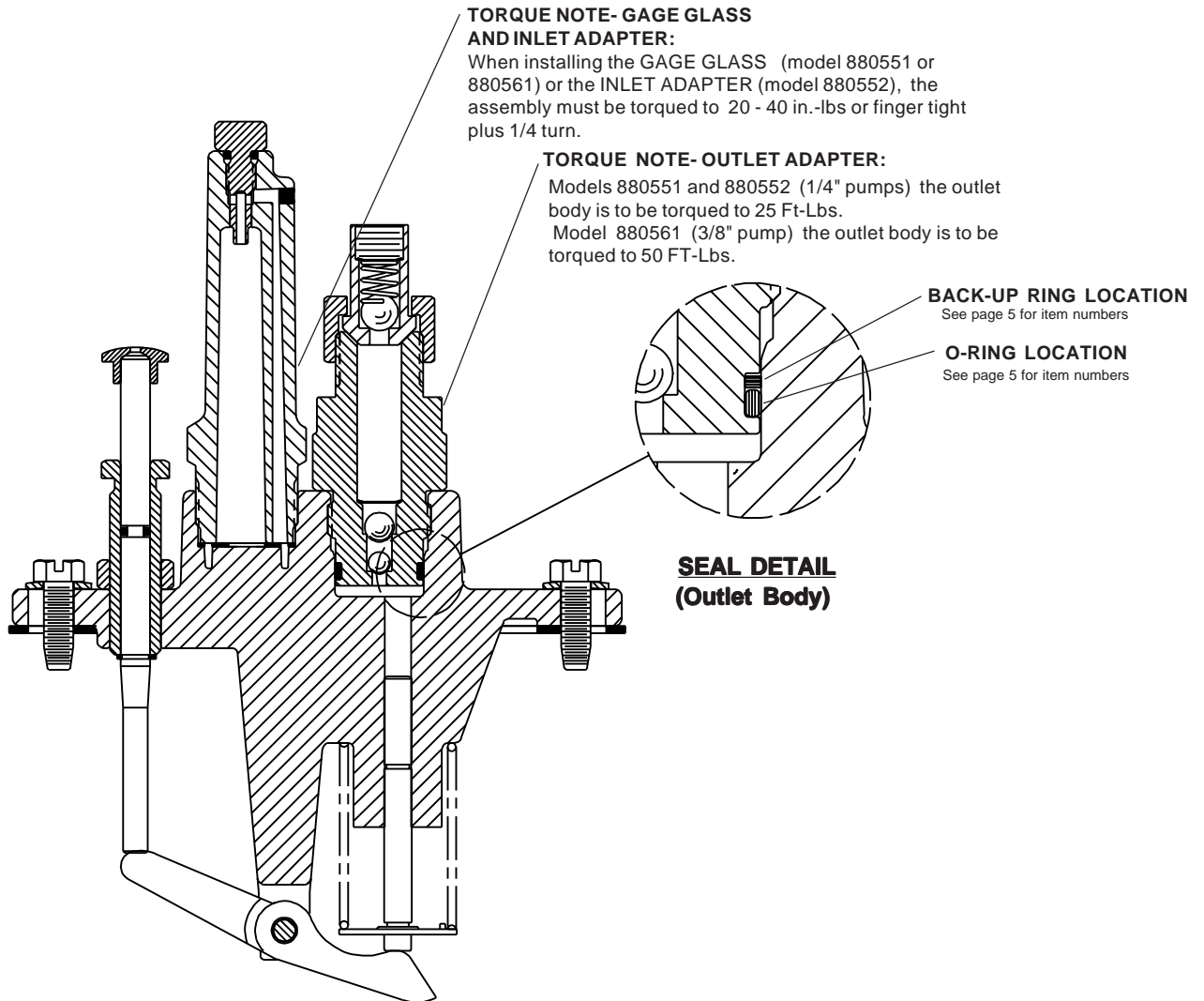

**PUMP DESCRIPTION (MODELS 880551 & 880561)**

The Model 55i Lubricator Pump is an improved version of the previous Lincoln Model 55 Lubricator Pump. Pump performance and serviceability have been improved with the Model 55i. The pump has been simplified by reducing the part count. The number of seals have been reduced by creating a unit pump body and sight glass, thus reducing the number of service parts and possible leak problems.

Models 880551 and 880561 are pressurized inlet pumps, intended to be used with either a pressurized oil supply or an overhead, gravity feed oil reservoir. A sight feed glass is

provided for monitoring oil flowing into the pump and setting output volume from the pump. Oil drips are now visible in the sight glass, enabling the user to make accurate output adjustments. Oil drips will be visible up to about 60 PSI depending on oil viscosity and sight glass oil level.

The pressurized inlet type pumps may be used when a remote oil supply is required, for increased capacity, high viscosity oils, or when an overhead day tank is required for removing air from the pump's oil supply. These pumps do not consume oil from the lubricator reservoir on which the pumps are mounted. Oil must be maintained in the lubricator reservoir to lubricate the drive and cam

components.

Models 880551 and 880561 are provided with a flexible nylon tube and shut off valve for connecting to an inlet supply manifold, or other lubricant source.

**PUMP DESCRIPTION, MODEL 880552**

Model 880552 is a pressurized inlet type of pump, similar to the models described above, except that a sight glass is not provided for monitoring oil flow through the pump. Oil is supplied to the pump directly through an inlet fitting on top of the pump, in place of a sight glass.

Continued on page 4

Maximum recommended oil viscosity is 8000 SUS.

#### PUMP OPERATION

The pump is operated by a rotating cam against the pumps rocker arm, causing the pump's plunger to reciprocate within it's bore in the pump body.

The pump output is set by the adjusting sleeve on top of the pump body. The sleeve limits the stroke length of the pump plunger thus limiting the pump output. Full pump output may be obtained when the adjusting sleeve is fully extended out of the top of the pump body, allowing for full plunger stroke.

#### SUCTION STROKE (SIGHT GLASS MODELS)

As the plunger moves downward, oil is drawn through the suction check and into the plunger bore from the small reservoir in the sight glass. Reducing the volume of oil in the sight glass creates a vacuum which draws oil from the lubricator reservoir, through the suction tube and into the outside passage in the sight glass. The oil will then enter the dropper and drip into the sight glass reservoir, replacing the oil removed by the suction stroke. The quantity of oil delivered may be determined by counting the drops of oil falling out of the dropper.

#### SUCTION STROKE (WITH OUT SIGHT GLASSES)

As the plunger moves downward, oil is drawn through the inlet adapter, the suction check and into the plunger bore.

#### DISCHARGE STROKE

As the plunger moves upward, oil is forced from the plunger bore through the outlet checks and into the lubrication point feedline. The suction check prevents any back flow of oil into the sight glass assembly and allows any oil that may bypass the plunger to be returned to the sight glass, area through a return passage.

#### STARTING INSTRUCTIONS

1) Connect the pump inlet to a oil supply source. Pressure to the pump must be no greater than 100 PSI on Models 880551 and 880561, (250 PSI on Model 880552) and must be less than the system pressure. For best results, inlet pressure should be no more than the pressure required to keep the pumps primed.

2) The oil level in the sight glass before starting will depend on the pressure used to supply oil to the pumps. As the inlet oil pressure increases, the air gap above the oil in the sight glass will decrease, reducing the visibility of the dripping action. If the pressure is high enough, (50 to 100 PSI), the oil level may rise to the point where the dripping action can not be observed. There fore it is recommended that the oil level in the sight glass, before starting be near empty.

When the inlet oil pressure is low, such as on a gravity feed supply, the air gap above the oil will be large enough to view the dripping action of the sight glass. Before starting it is recommended that the oil level in the sight glass be 1/3 to 2/3 full.

3) Manually operate the pump with the priming stem until oil, without air bubbles, flows from pump outlet.

4) Connect the feedline to the pump outlet union and manually operate the pump with the priming stem until the feedline is filled.

5) Connect the feedline to the lubrication point. A feedline check valve at the lubrication point is recommended and is available as an accessory item.

6) Fill the lubricator reservoir with lubricant and adjust the pump output as necessary for the application.

#### SETTING PUMP OUTPUT (GAGE GLASS MODELS)

Count the number of drops falling through the sight glass in one minute. Set the adjusting sleeve to obtain the desired quantity and secure the setting with the locknut.

#### Conversion factors:

1 drop = .002 cu. in.

500 drops = 1 cu. in.

#### SIGHT GLASS:

The sight glass gives a visual indication of the condition of the oil flowing through the lubrication pump.

An increasing oil level indicates absorption of air in the sight glass by the oil passing through. Over fill eliminates visual metering of drops in the sight glass, but has no effect on pump operation.

A decreasing oil level indicates the vacuum in the sight glass is withdrawing entrained air from the oil passing through the sight glass. **If the decreasing oil level is allowed to continue, an air lock can result.**

Under normal conditions, the oil level will raise or fall until an equilibrium is reached, but may change from time to time as the condition of the oil changes. Regardless of the oil level, a continuing passage of the correct oil volume indicates that the pump is operating properly.

If the oil level in the sight glass rises to the point of filling the sight glass, this is an indication of a possible leak in the sight glass area of the pump. Check for leaking oil around the sight glass.

A steady rise in the oil level of the gage glass over a short period of time may indicate a dirty or bad inlet check in the pump body. Clean the pump body and check ball.

#### AIR LOCK:

Air locking occurs when air, instead of oil, enters the plunger bore and can not be compressed to a high enough pressure to be forced out of the pump against the feedline back pressure.

Air locking is caused either by entrained air being separated from the oil by the vacuum in the sight glass, or by air entering the pump when the oil level in the oil reservoir is low, a vacuum leak in the pump's inlet circuit, or an insufficient priming pressure on the inlet. Severely agitated oils, such as oil supplied from a crankcase, will usually contain entrained air. An air lock can

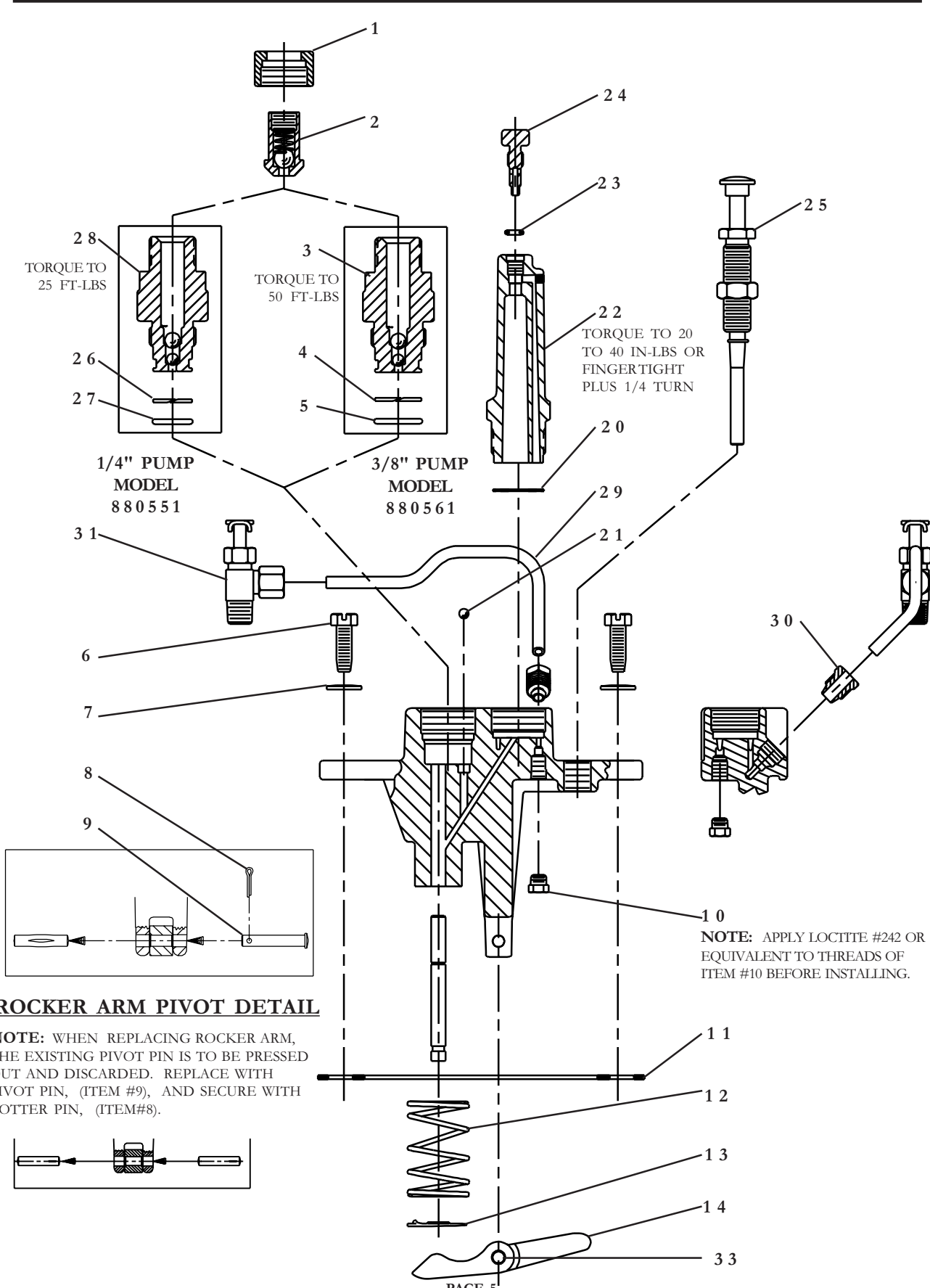

TORQUE TO  
25 FT-LBS

TORQUE TO  
50 FT-LBS

TORQUE TO 20  
TO 40 IN-LBS OR  
FINGERTIGHT  
PLUS 1/4 TURN

1/4" PUMP  
MODEL  
880551

3/8" PUMP  
MODEL  
880561

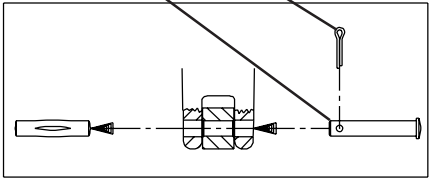

**ROCKER ARM PIVOT DETAIL**

**NOTE:** WHEN REPLACING ROCKER ARM, THE EXISTING PIVOT PIN IS TO BE PRESSED OUT AND DISCARDED. REPLACE WITH PIVOT PIN, (ITEM #9), AND SECURE WITH COTTER PIN, (ITEM#8).

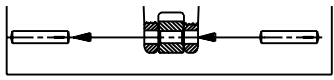

**NOTE:** APPLY LOCTITE #242 OR EQUIVALENT TO THREADS OF ITEM #10 BEFORE INSTALLING.

be easily detected since, when it occurs, no oil will be visible in the sight glass. If entrained air is found to be a problem, either a pressurized pump supply or a settling tank should be utilized.

An air lock can be eliminated by refilling the oil reservoir, and sight glass, loosening the outlet union at the pump outlet, and manually operating the pump with the priming stem until no air bubbles appear at the pump outlet.

**CAUTION:** On pressurized systems be sure all pressure is removed from pump inlet before removing dropper from the gage glass.

The air lock may reoccur if the cause is not found and eliminated.

**OVERFILL:**

Over filling is caused by the oil absorbing the air in the sight glass as it passes through the pump.

This condition does not affect the operation of the pump except that the oil can not be observed coming out of the dropper due to the sight glass being filled with oil.

Normal sight glass operation may be restored by closing the inlet shut off valve to the pump to remove pressure from the pump. Then after pressure is removed, while pump is operating, remove the dropper from the gage glass long enough for the oil level in the glass to drop to an acceptable level. Reinstall the dropper, and open the inlet valve. Leaving the dropper out for an extended period of time may allow the pump to drain enough oil from the gage glass to become air bound.

**CAUTION:** On pressurized systems be sure all pressure is removed from pump inlet before removing dropper from the gage glass.

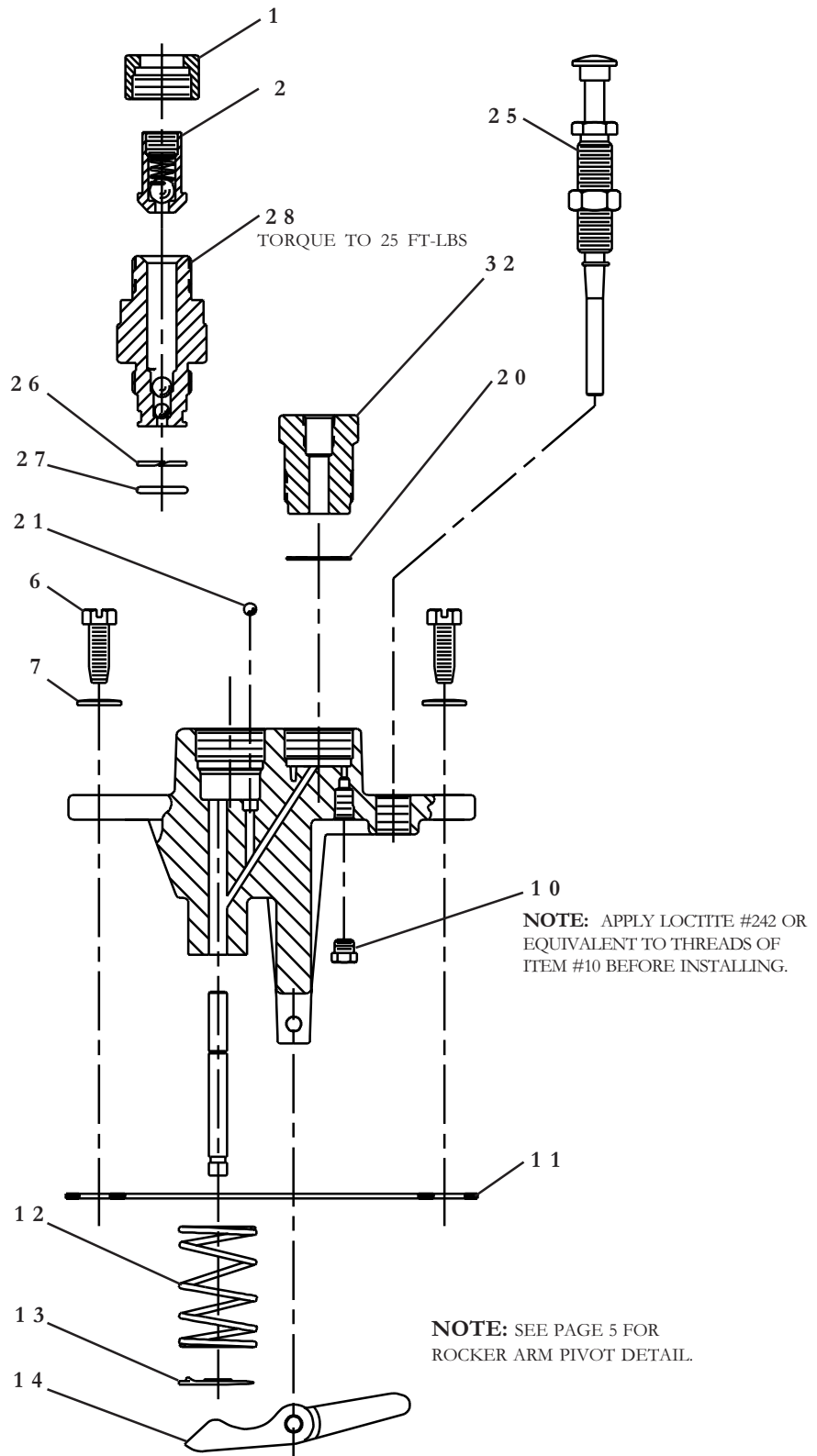

**NOTE:** SERVICE PARTS FOR MODELS 880551,880552 AND 880561 ARE AVAILABLE ONLY IN THE SERVICE KITS LISTED BELOW. INDIVIDUAL SERVICE PARTS AND PARTS NOT LISTED BELOW ARE NOT AVAILABLE. QUANTITIES IN KITS ARE ONE EACH UNLESS OTHERWISE SPECIFIED.

**NOTE:** THE ILLUSTRATIONS ON THIS PAGE ARE SHOWN ACTUAL SIZE.

ITEM NO	DESCRIPTION
10	13190 PLUG
<b>250142 SIGHT GLASS KIT</b>	
20	SIGHT GLASS SEAL
22	SIGHT GLASS
23	O-RING
24	DROPPER
<b>250143 PUMP MOUNTING KIT</b>	
6	MOUNTING SCREW (2 SUPPLIED)
7	BELLEVILLE WASHER (2 SUPPLIED)
11	PUMP MOUNTING GASKET
<b>250144 PUMP SEAL KIT (3/8" PUMP)</b>	
4	BACK-UP RING (OUTLET BODY)
5	O-RING (OUTLET BODY)
16*	O-RING (SUCTION TUBE)
18*	BALL (SUCTION TUBE)
20	SIGHT GLASS SEAL
21	BALL (INLET CHECK)
23	O-RING (DROPPER)
<b>250146 OUTLET UNION ASSEMBLY</b>	
1	UNION NUT (OUTLET)
2	SLEEVE ASSY (OUTLET)
<b>250166 CHECK KIT (3/8" PUMPS)</b>	
3	ADAPTER ASSEMBLY (W/BALLS)
4	BACK-UP RING
5	O-RING
<b>250167 ROCKER ARM KIT</b>	
8	COTTER PIN
9	PIVOT PIN
12	SPRING (PLUNGER RETURN)
13	SPRING RETAINER
14	ROCKER ARM
25	250169 PRIMING UNIT ASS'Y.
<b>250171 DROPPER ASS'Y.</b>	
23	O-RING
24	DROPPER
<b>250172 PUMP SEAL KIT (1/4" PUMP)</b>	
26	BACK-UP RING (OUTLET BODY)
27	O-RING (OUTLET BODY)
16*	O-RING (SUCTION TUBE)
18*	BALL (SUCTION TUBE)
20	SIGHT GLASS SEAL
21	BALL (INLET CHECK)
23	O-RING (DROPPER)
<b>250173 CHECK KIT (1/4" PUMPS)</b>	
26	BACK-UP RING
27	O-RING
28	ADAPTER ASSEMBLY (W/BALLS)
29	250217 NYLON TUBE
30	250218 COMPRESSION NUT
31	250219 VALVE ASSEMBLY
<b>250220 ADAPTER ASS'Y.</b>	
20	SIGHT GLASS SEAL
22	ADAPTER

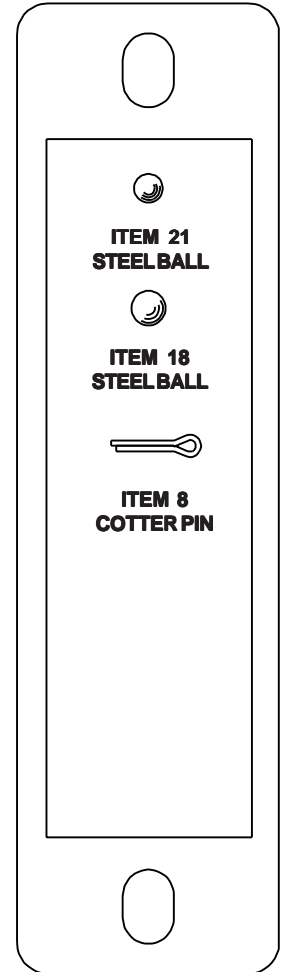
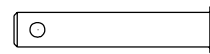
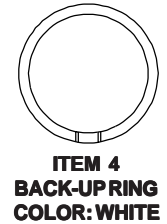

ITEM 11  
PUMP MOUNTING  
GASKET



\* INDICATES PARTS SUPPLIED IN KITS WHICH ARE NOT USED IN MODELS LISTED ON THIS FORM

---

# LUBRICATOR ACCESSORIES

## **Lube Sentries**

---

**Model 880555** Monitors camshaft rotation and reservoir oil level. See Service Manual Section M30, Page 33 Series.

**Model 880556** Same as 880555 except with 1" short suction tube. See Service Manual Section M30, Page 33 Series.

## **Oil Level Regulator**

---

**Model 880496** Automatically fills lubricator reservoir. See Service Manual Section M30, Page 32 Series.

## **Lubricator Flow Switches**

---

**Note:** To be used with non-conductive fluids only.

**Caution:** Lubricator must be properly grounded.

**Model 880463** Used on individual Type 55 Lubricator pumps to monitor lubricant flow. See Service Manual Section M31, Page 9 Series.

**Model 880466** Same as 880463 except includes terminal for series wiring. See Service Manual Section M31, Page 9 Series.

## **Armored Pump Sight Glass**

---

**Model 250176** Armored sight glass kit with pyrex sight tube. Adapts the old Model 55 sight glass assembly to the new Model 55i pump assembly.

—— **RETAIN THIS INFORMATION FOR FUTURE REFERENCE** ——

When ordering replacement parts, list: Part Number, Description, Model Number, and Series Letter.

LINCOLN provides a Distributor Network that stocks equipment and replacement parts.

---