

The MCLP Pump Head is mounted to an MCLP Gear Box. By the action of a cam in the gear box, the pump plunger is pushed upward on the delivery stroke and returned to priming position by the plunger return spring.

The pump head requires a filtered oil supply by either gravity or under slight head pressure (up to 50 psi). Recommended filtration; 10 microns. Lube inlet is located on right side of pump (3/8" NPTF).

The MCLP Pump Head is available with 7 mm and 10 mm pistons. An adjustment knob on the front of the pump allows for variations in the quantity of oil delivered.

Output is determined by multiplying:

Input Speed x Gear Ratio x Constant = PPD (pints/day)

	Minimum Output *Constant	Maximum Output *Constant
7 mm	0.100 ©	0.852
10 mm	0.213	1.491

\*When using a double lobe cam, multiply constant by 2.

**NOTES: 1. The camshaft in the gear box should not exceed 162 revolutions per minute.**

**2. Verify minimum output setting due to the possibility that the pump output can be completely shut off. ©**

	MCLP Replacement Pump Head Assembly	MCLP Pump Head
7 mm	130332	130331
10 mm	130335	130334

Maximum working pressure should not exceed the following:

7mm - 8,000 psi

10mm - 3,500 psi

An anchor cross is located at the top of the MCLP Pump Head which includes the following:

- Purge port with check valve for priming the system
- Two Lube Outlets (1/4" NPTF)

- Plugged outlet for pressure gauge location (1/4" NPTF)

- Rupture indicator to atmosphere

Piston and barrel assemblies are closely fitted to ensure the discharging of oil at high pressures. There is some clearance between these two parts, therefore some leakage of oil past these parts will occur. This normal leakage is required for lubrication of the upper tappet assembly. As a result, the oil being pumped will pass through the pump and enter the MCLP Gear Box. It may be necessary to drain the gear box occasionally, to keep the oil level from rising above the full mark.

As the piston and barrel wear, more leakage will occur. This should be of no concern unless the leakage becomes great enough to prevent the pump from producing the required pressure and oil volume.

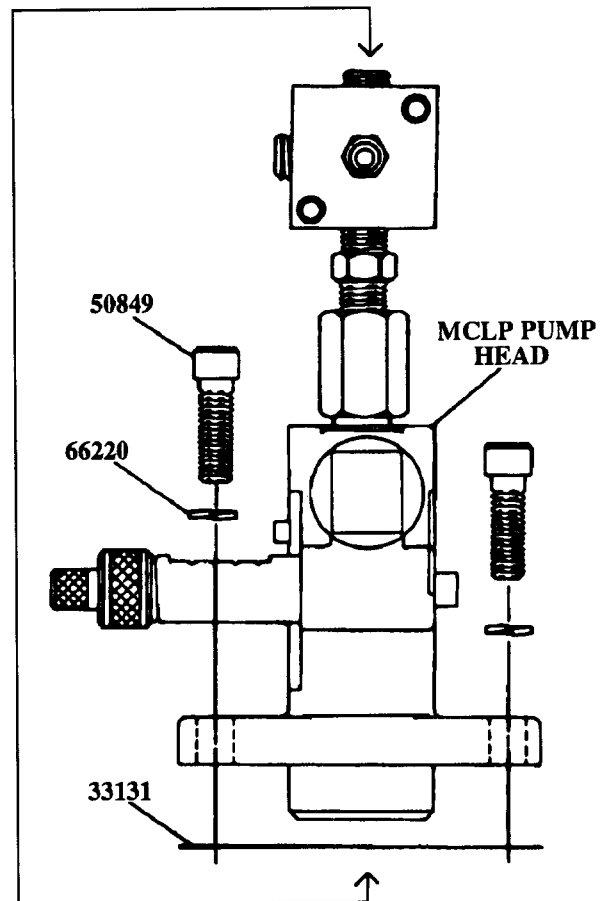

© Indicates Change

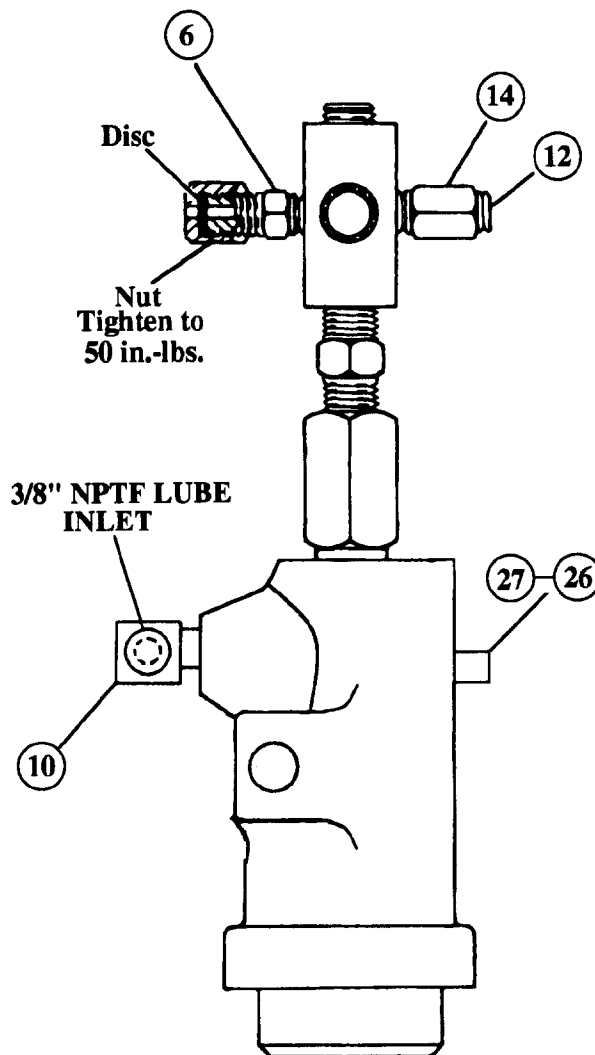

### MODEL CHART

MODEL	NUT	DISC (6 INCLUDED)	RELIEF PRESSURE	REPAIR KIT (ITEMS 1,2,3,4)
130332 7mm Pump Head Assembly	15055	69813-14 (Orange)	5500 psi	247416
130335 10mm Pump Head Assembly	15054	69813-22 (Purple)	3250 psi	247417

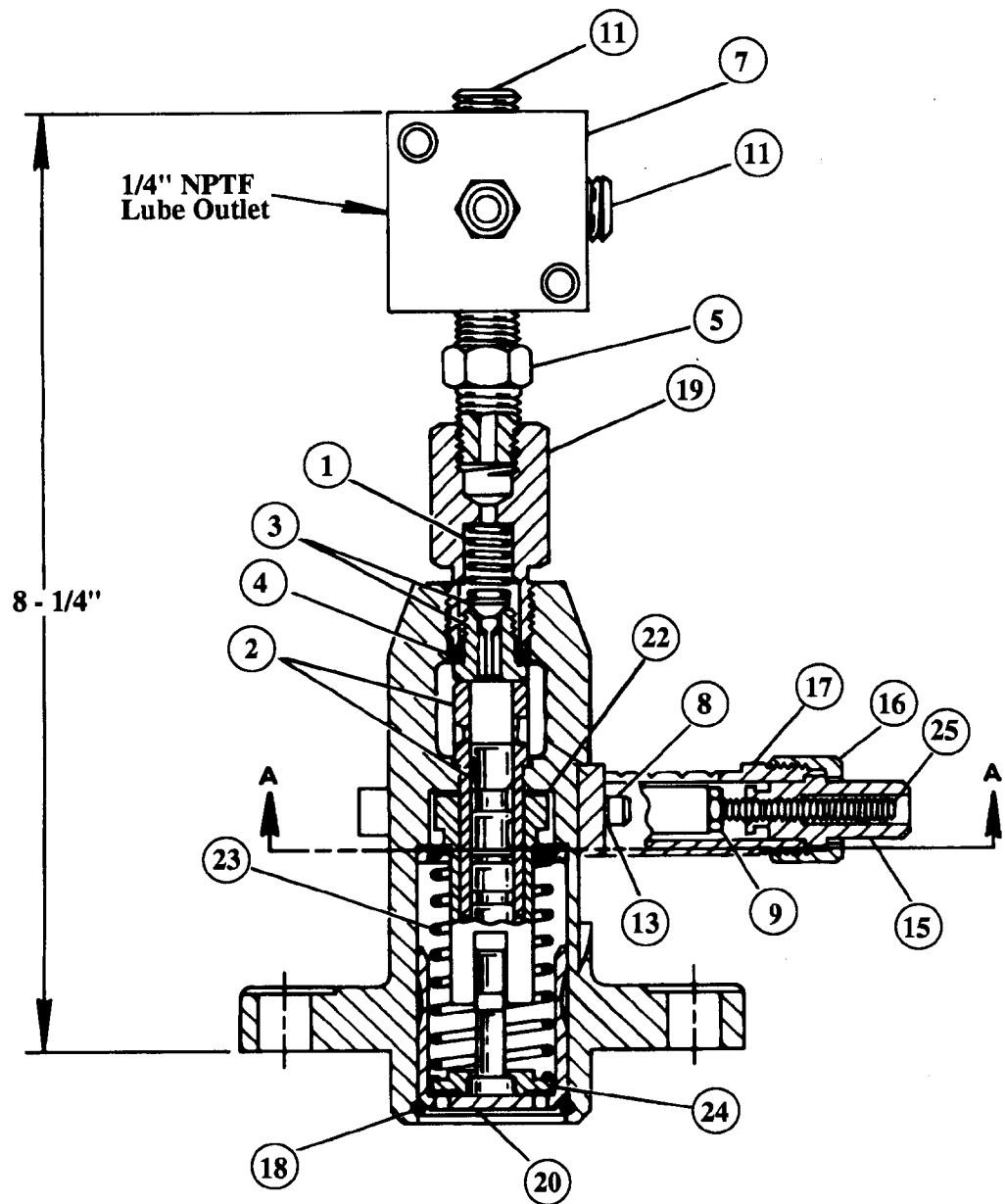

Notch on Control Sleeve (247426)

Dot on Control Rack (247425)

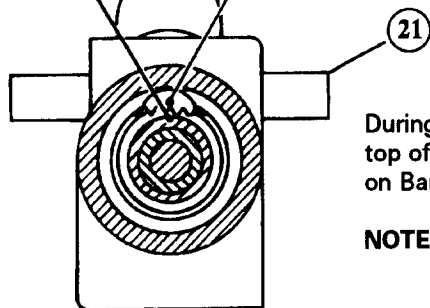

**SECTION A-A**

During assembly, Barrel must be installed through top of Pump Housing and located with slotted port on Barrel facing Bleed Screw opening.

**NOTE:** Notch on plunger & notch on 247426 must coincide for proper pump operation.

**NOTE:** Notch on 247426 & dot on 247425 must coincide for proper pump operation.

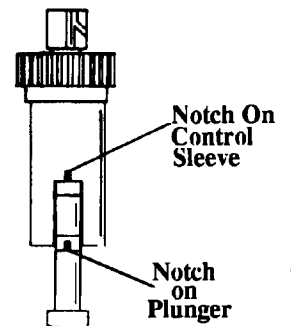

### SERVICE PARTS

ITEM	PART	QTY	DESCRIPTION
1	SEE NOTE #1	1	SPRING, DELIVERY VALVE
2	SEE NOTE #1	1	PISTON & BARREL ASSEMBLY
3	SEE NOTE #1	1	DELIVERY VALVE
4	SEE NOTE #2	1	GASKET, DELIVERY VALVE
5	10462	1	NIPPLE
6	15052	1	CONNECTOR
7	15775	1	ANCHOR CROSS
8	50846	1	CAPSCREW
9	51043	1	HEX NUT
10	© 67031	1	ELBOW
11	67359	2	PLUG
12	68645	1	PLUG
13	68991	1	WASHER
14	130021-3	1	CHECK VALVE ASSEMBLY
15	247418	1	ADJUSTMENT KNOB
16	247419	1	LOCKING NUT
17	247421	1	ADJUSTMENT HOUSING
18	247422	1	SNAP RING
19	247423	1	OUTLET HOUSING
20	247424	1	GUIDE CUP
21	247425	1	CONTROLRACK
22	247426	1	CONTROL SLEEVE
23	247428	1	SPRING, PUMP PISTON
24	247429	1	SPRING PLATE
25	247430	1	ADJUSTMENT SCREW
26	247432	1	BLEED SCREW
27	247442	1	GASKET, BLEED SCREW

© Indicates Change

**NOTE:**

1. These components are available only as components of Repair Kit.
2. This component is included in Repair Kit or can be purchased separately as part number 247427.

**RETAIN THIS INFORMATION FOR FUTURE REFERENCE**

When ordering replacement parts, list: Part Number, Description, Model Number and Series Letter.  
LINCOLN provides a Distributor Network that stocks equipment and replacement parts.