

R.H. END DRIVE
1:1 RATIO
INCLUDES VITON OIL SEALS

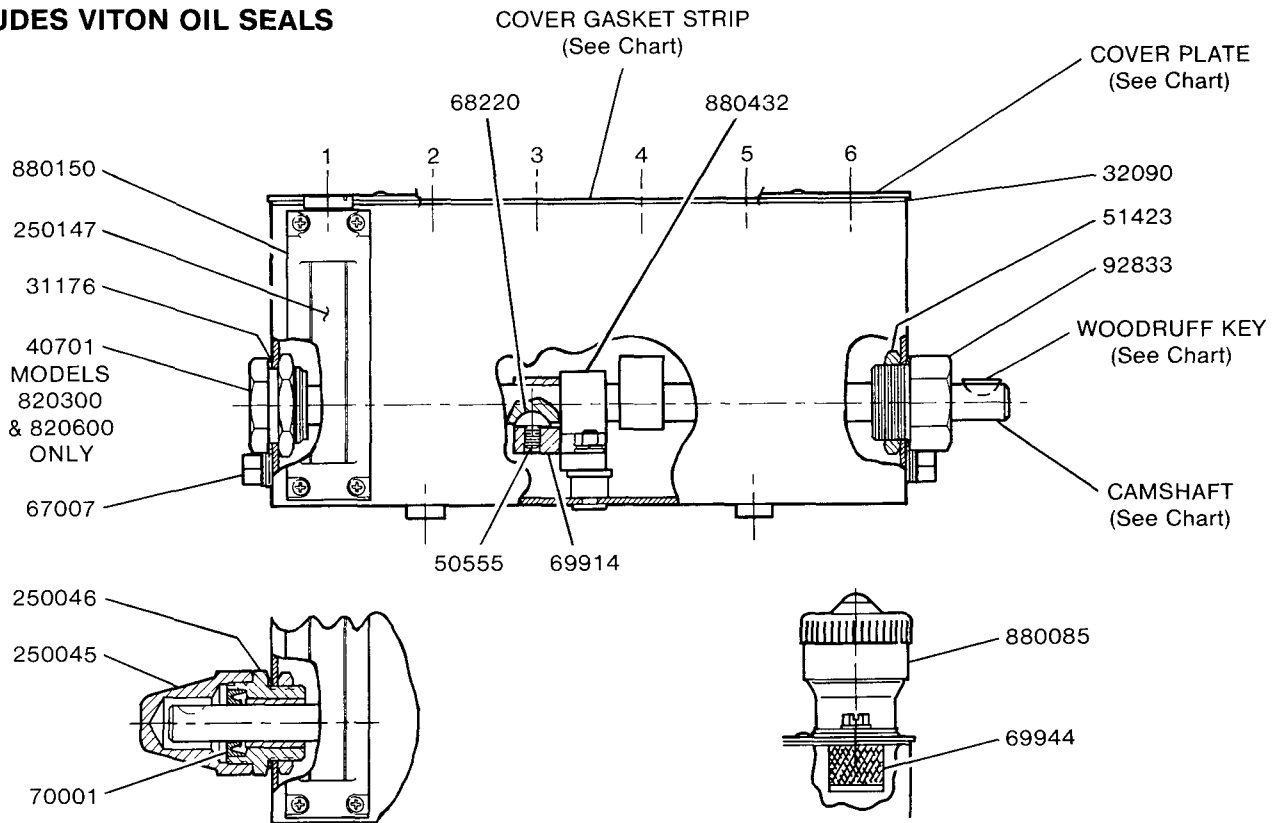

END DETAIL

MODEL 820400 ONLY

FILLER ASSEMBLY

MODEL 820400 ONLY
(Accessory with 820300 and 820600)

DESCRIPTION

The **Tandem Lubricator System** consists of an 8 pint primary lubricator, with provisions for adding a secondary lubricator, to increase capacity. The primary lubricator may be driven by an electric motor, machine driven directly, or through chains, belts or a gear reducer. The primary lubricator may be supplied with an internal gear reduction, and will have an extended cam shaft to allow for coupling to the cam shaft of a secondary lubricator.

Models 820300 and 820600 are designed for use as secondary lubricators, but may be used as an independent lubricator when a secondary lubricator is not required. (Models 820300 and 820600 do not have provisions for the addition of a secondary lubricator.) **Model 820400** may be used as either a primary, or secondary lubricator, and incorporates an extended cam shaft for coupling to a secondary unit. A shaft cover is provided for covering the extended cam shaft when it is not utilized.

Models 820300, 820400 and 820600 are direct drive units. There is no drive reduction between the lubricator drive shaft and cam shaft. The direct drive lubricator cam shaft speeds must be limited to less than 30 RPM. In most instances some form of drive reduction will be required.

For more information on coupling and mounting the **Tandem Lubricators** consult service manual Section M2 Page 40 Series. For information on the primary lubricators with self contained drive reductions, see service manual Section M2 Page 218 Series.

PUMP MOUNTING

When pumps are mounted to the reservoirs, care should be taken to place the pumps with the highest back pressures closest to the driven end of the lubricator assembly. When a secondary lubricator is used, pumps operating over 4000 PSI **MUST** be placed on the primary lubricator.

SERVICE INSTRUCTIONS

1. Removal of pumps, filler, and cover plate will allow access to the cams and cam shaft assembly.
2. Loosen the set screw (50555) in each cam (69914). Slide each cam clear of it's respective woodruff key (68220). Remove the keys from the cam shaft. Remove the end bearing assembly (40701 or 250043) from the end of the reservoir. Slide the cam shaft out of the stuffing box assembly (880251) and the center bearings (880432). As the cam shaft is removed from the reservoir, the cams must be removed as the cam shaft passes through each center bearing. Remove and discard the shaft oil seals (70001) from the stuffing box(es).
3. Do not remove the center bearings from the reservoir assembly unless they require replacement.
4. Clean and inspect all parts for wear and damage. Pay close attention to wear on cams and cam shaft. Inspect the reservoir for cracks and damage. Worn or damaged parts should be replaced. Always replace shaft seals (70001) when ever shaft is removed. If center bearings require replacement, they will have to be aligned with the cam shaft to the end bearing and stuffing box assembly by placing shims as required between the center bearing and the bottom of the reservoir. (Shims are supplied with the center bearing assembly.)
5. Start reassembly by positioning the cams in their respective pump station location inside the reservoir, between the bearings. Slide the camshaft into the reservoir through the end bearing hole, and place each cam onto the cam shaft while sliding the camshaft into the bearings. Install the end bearing and nut (51423), tightening securely. Install the woodruff keys (68220) into the camshaft, slide the cams into position over each key. Align the cams with the pump mounting holes in the top of the reservoir. Slide the end cams up against the end bearing and stuffing box to hold the cam shaft into position. Adjust the cams if necessary to align with the holes in the top of the reservoir, and secure with the set screw (50555).
6. Rotate the cam shaft and check for excessive drag on the cam shaft. Excessive torque on the cam shaft will cause additional wear on the drive components. Install new shaft oil seal(s) (70001).
7. Reinstall cover plate, filler assembly and pumps. Replace gaskets if necessary. Inspect the pumps for wear on the rocker arms, replacing as required. Fill with lubricant and check for leaks.

SERVICE PARTS

Part No.	Description	Model 820300	Model 820400	Model 820600
		Qty.	Qty.	Qty.
31176	End bearing gasket	2	2	2
32090	End cover gasket	2	2	2
40701	End bearing	1	NA	1
50555	Set screw	6	8	15
51423	Nut	2	2	2
67007	Pipe plug	2	2	2
68220	Woodruff key	7	8	15
69914	Cam lobe	6	8	15
69944	Strainer	As req'd.	1	As req'd.
69973	Woodruff key	NA	1	1
70001	Oil seal	1	2	1
92833	Stuffing box assembly	1	1	1
250045	Shaft cover	NA	1	NA
250046	Stuffing box assembly	NA	1	NA
250048	Cam shaft	1	NA	NA
250049	Cam shaft	NA	1	NA
250050	Cam shaft	NA	NA	1
250083	Cover gasket strip	2	NA	NA
250084	Cover gasket strip	NA	2	NA
250086	Cover gasket strip	NA	NA	2
250147	Gage glass kit	1	1	1
360659	Cover plate	1	NA	NA
360661	Cover plate	NA	1	NA
360664	Cover plate	NA	NA	1
880085	Filler assembly	As req'd.	1 *	As req'd.
880093	Slot cover assembly	As req'd.	1 *	As req'd.
880150	Gage glass (complete)	1	1	1
880432	Center bearing assembly **	1	2	4

NA: Part is not applicable to model.

* One unit is supplied with Model 820400, others may be ordered as required.

** 880432 includes shims for alignment.

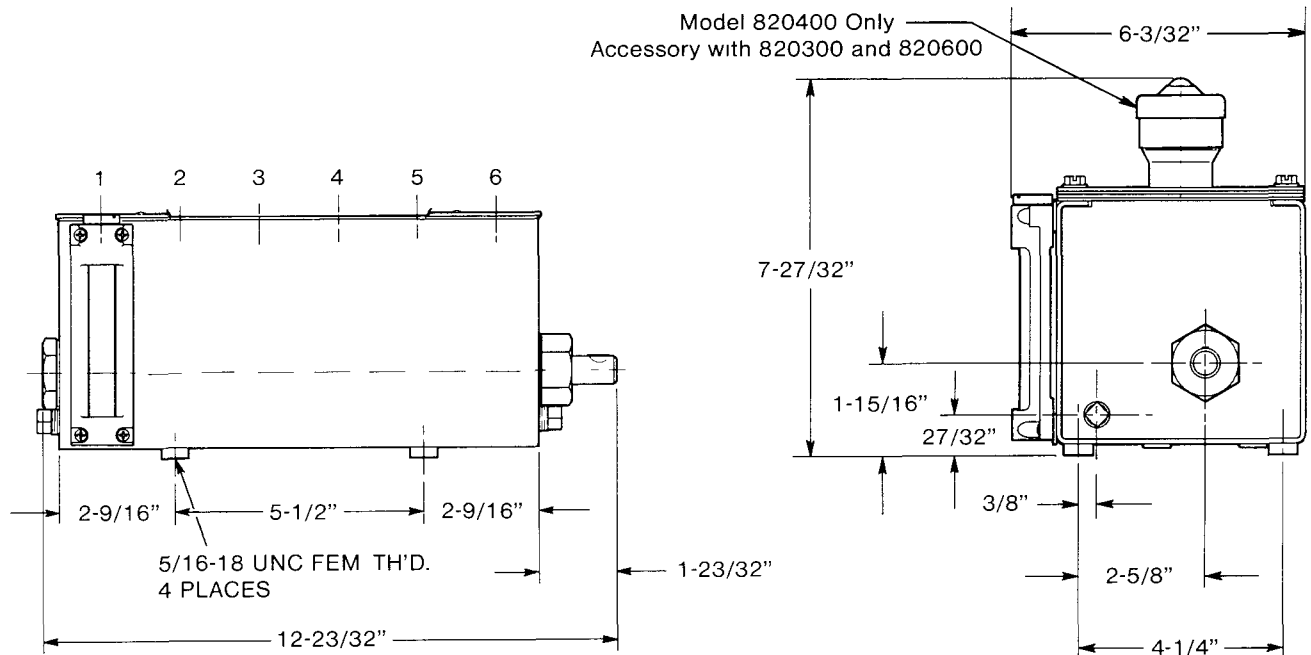

MODEL 820300

**END VIEW TYPICAL
FOR ALL MODELS**

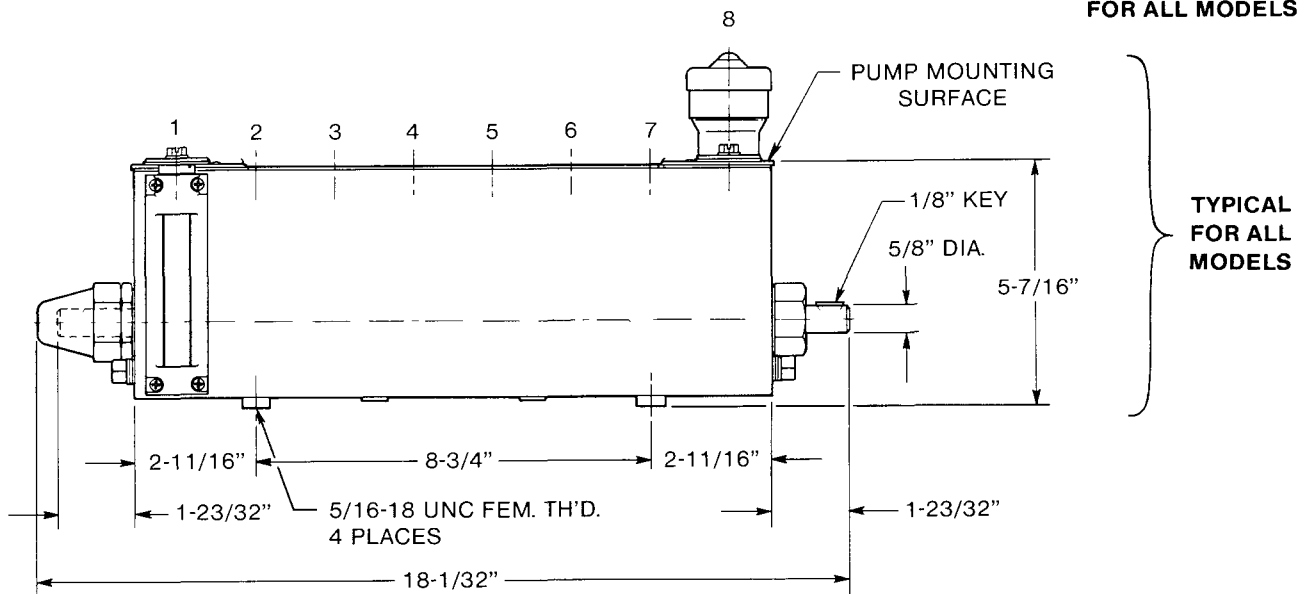

MODEL 820400

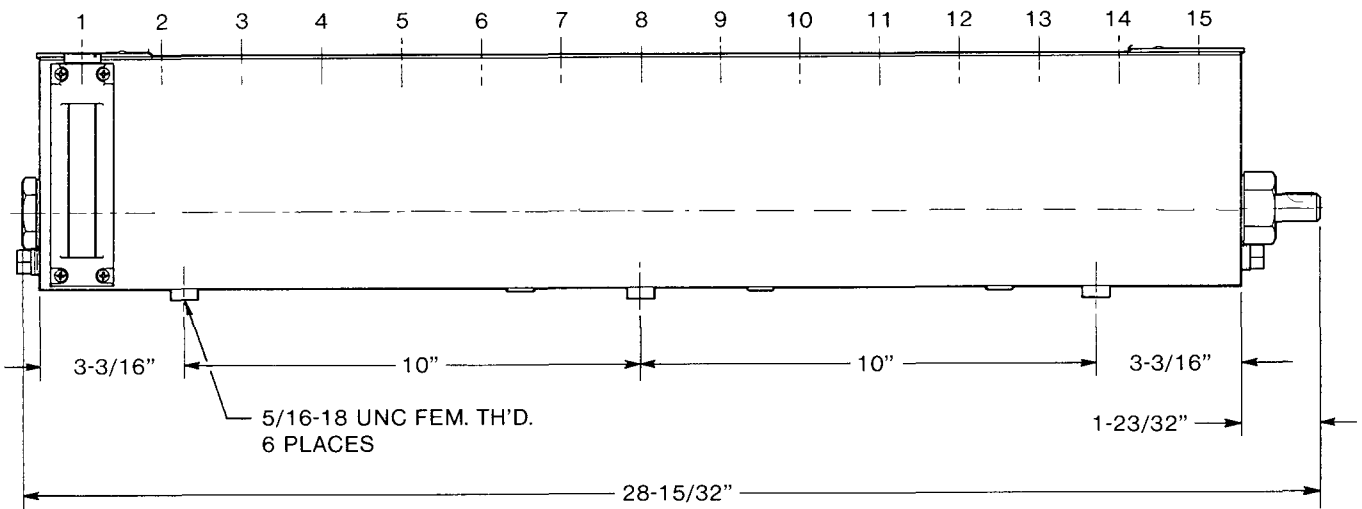

MODEL 820600

LUBRICATOR ACCESSORIES

Lube Sentries

- Model 880447** Monitors camshaft rotation and reservoir oil level.
See Service Manual Section M30, Page 10 Series.
- Model 880456** Same as 880447 except with 1" Short Suction Tube.
See Service Manual Section M30, Page 10 Series.

Oil Level Regulator

- Model 880496** Automatically fills lubricator reservoir.
See Service Manual Section M30, Page 9 Series.

Lubricator Flow Switches

- Note:** To be used with non-conductive fluids only
Caution: Lubricator must be properly grounded.

- Model 880463** Used on individual Type 55 lubricator pumps to monitor lubricant flow.
See Service Manual Section M31, Page 9 Series.
- Model 880466** Same as 880463 except includes terminal for series wiring.
See Service Manual Section M31, Page 9 Series.

———— **RETAIN THIS INFORMATION FOR FUTURE REFERENCE** ————

When ordering replacement parts, list: Part Number, Description, Model Number and Series Letter.

LINCOLN provides a Distributor Network that stocks equipment and replacement parts.