

MODEL 87070 Series "D"

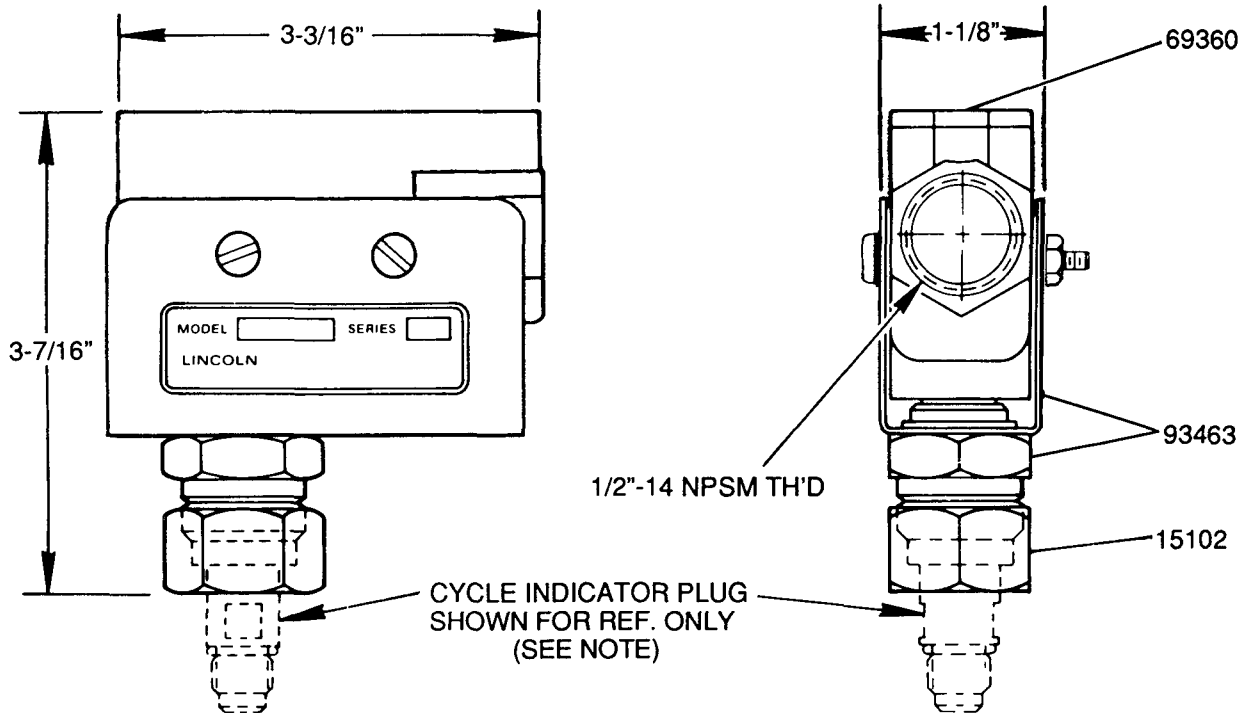

NOTE: Cycle indicator plug must be removed from divider valve block in order to couple to switch with 15102 Coupling Nut.

ELECTRICAL RATING

15 Amps at 125, 250 & 480V AC
0.5 Amp at 125V DC
1/3 HP at 125V AC
1/2 HP at 250V AC
SPDT

CIRCUITRY

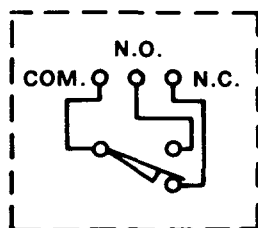

SERVICE PARTS

Part	Qty.	Description
15102	1	Coupling Nut
93463	1	Bracket & Adapter
69360	1	Limit Switch

© Indicates change

LINCOLN

® A PENTAIR COMPANY

One Lincoln Way
St. Louis, Missouri 63120-1578
(314) 679-4200
Customer Service, (314) 679-4300

Copyright 1989
Printed in U.S.A.

Section - M30
Page - 15C

Form 402224