

ELECTRICAL RATING

15 Amps at 125, 250 & 480V AC
0.5 Amps at 125V DC
1/3 HP at 125V AC
1/2 HP at 250V AC
SPDT

MODEL 87070

Series "D"

(Shown after assembly to cycle indicator plug)

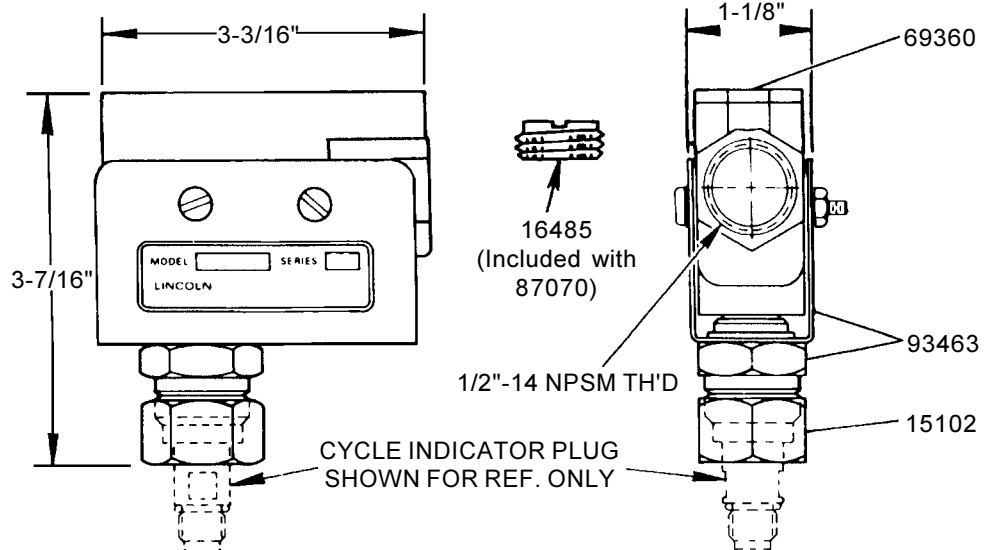
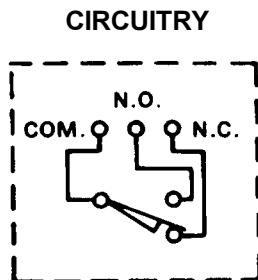

SERVICE PARTS

Part	Qty.	Description
15102	1	Coupling Nut
16485	1	Plug
69360	1	Limit Switch
93463	1	Bracket & Adapter

To Assemble Limit Switch To Divider Valve w/Cycle Indicator

*Install 16485
(Included w/
87070)

* Applies to series "A" valves only

NOTE: CYCLE INDICATOR PLUG MUST BE
REMOVED FROM DIVIDER VALVE IN
ORDER TO COUPLE TO SWITCH WITH
15102 COUPLING NUT.

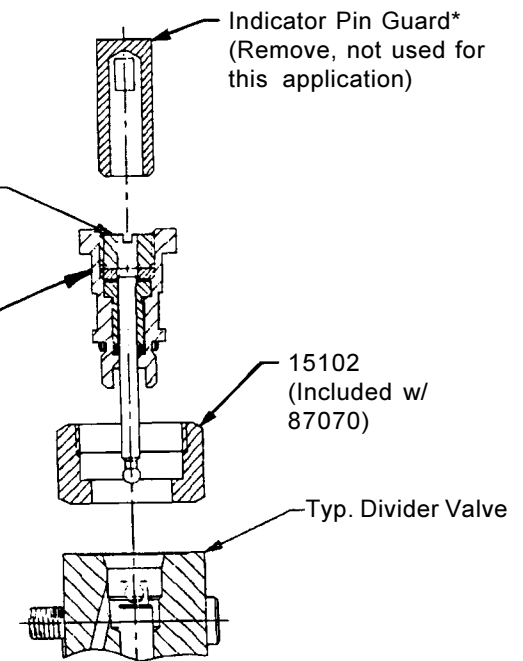

© Indicates Change