

FLOAT LEVEL CONTROLLER

This unit fits into the space of one lubricator feed and will automatically maintain correct oil level in the lubricator reservoir either from a remote main oil supply or from a gas engine crankcase.

Many installations are arranged to have an overhead storage supply tank which will provide sufficient head pressure to effectively operate this control valve.

The design of this control valve is such that it will effectively seal against head pressures of 5 to 60 PSI.

Includes safety switch terminals for grounding magnetos on gas engine should the oil level become dangerously low.

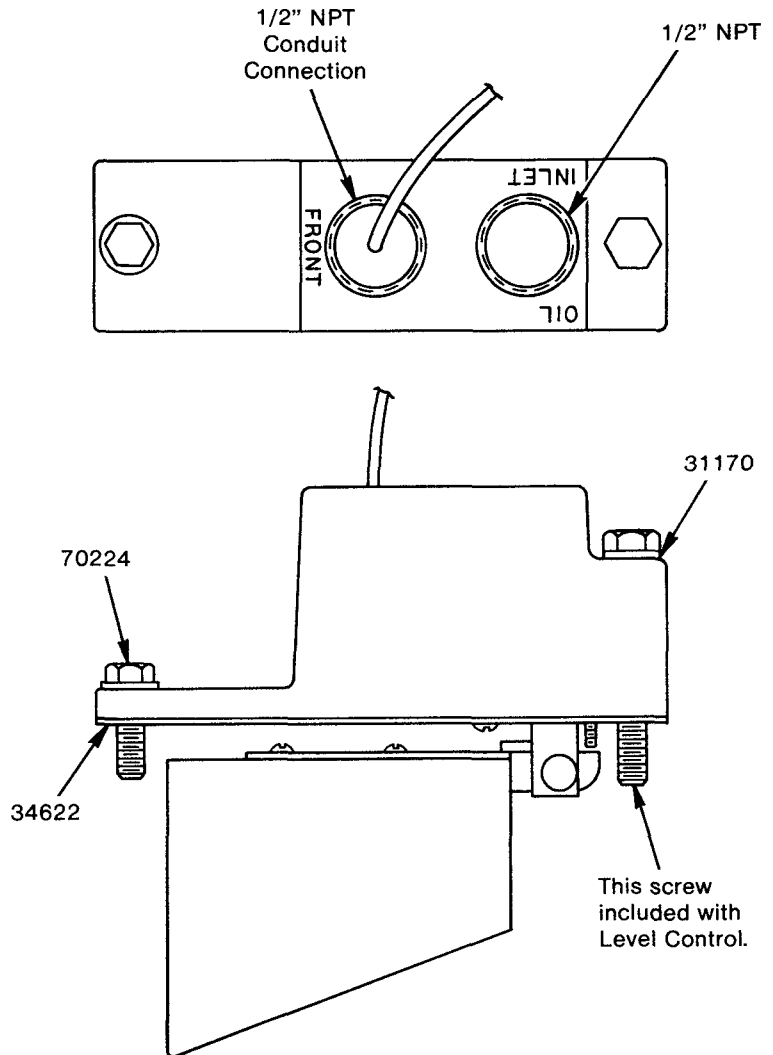

SERVICE PARTS

Part	Qty.	Description
31170	2	Gasket
34622	1	Gasket
70224	1	Screw