

DUAL TIMED CYCLE MONITOR

CSA CERTIFIED - FILE NO. LR-49957
SOLID STATE - 120 VAC, 50-60 Hz.
EXPLOSION PROOF



Model 87611

CLASS I, GROUP D; CLASS II, GROUPS E, F & G - HAZARDOUS LOCATIONS

Series "C"

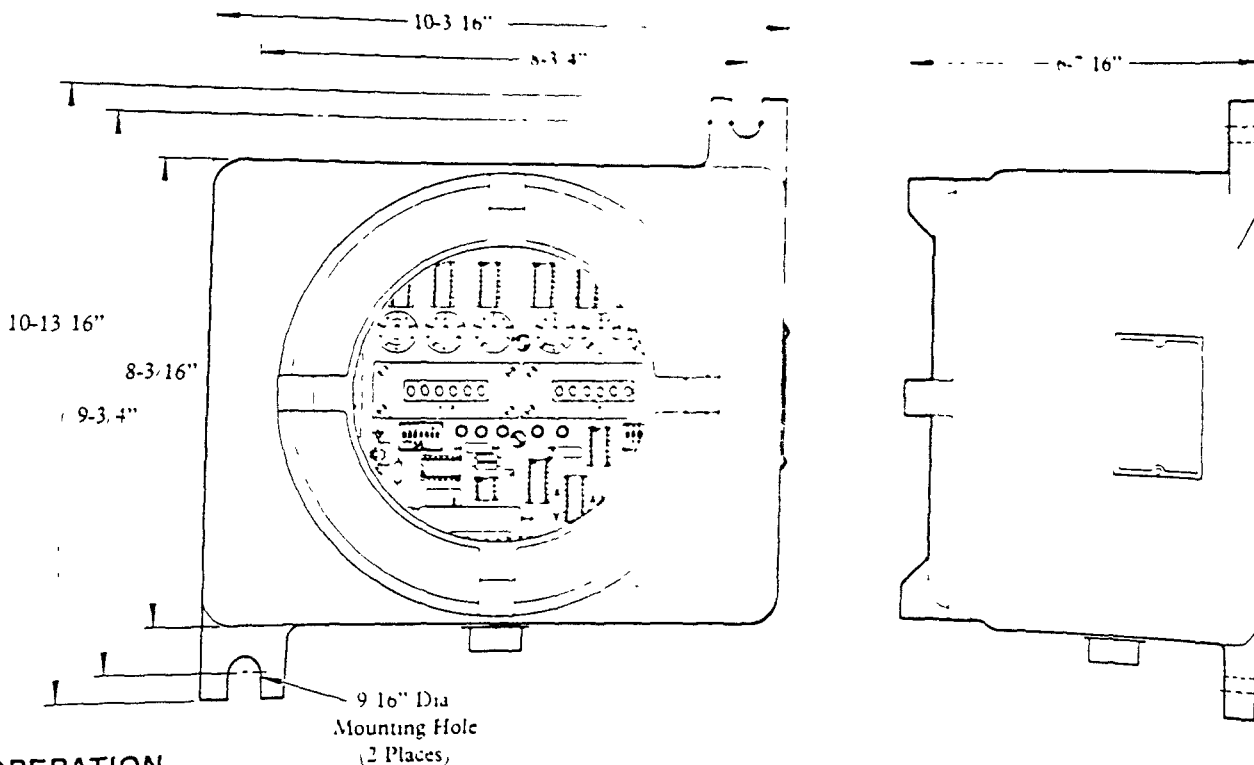

OPERATION

The dual timed cycle monitor is used for monitoring two independent lubrication systems. Although both systems are independent, they operate in the same manner. Lubricant flow through the control divider valve assembly causes the pistons in the assembly to cycle, operating the proximity switch. The proximity switch is actuated a predetermined number of times to equal one pint of oil. This predetermined number depends on the cycle volume of the control divider valve assembly. The cycle monitor is set to this predetermined number and once the number is reached the counter will register one, signifying one pint. When reading the counter no conversion is needed from counts to pints, the counter registers directly in pints. The counter has a six digit display which enables it to record pints for at least 30 days.

The cycle monitor will not go into alarm as long as the interval between proximity switch actuations is less than the alarm time setting. If either proximity switch is not actuated within their selected alarm times, the alarm relay is energized. Subsequent actuation of the proximity switch (that caused the alarm) will de-energize the alarm relay. Use of the alarm lockout (see figure 2 on inside page) will prevent proximity switch from canceling the alarm. The alarm relay can be used to shut down the engine and signal an alarm.

EXAMPLE:

A divider valve assembly consisting of three MC12 Metering Valves would require .072 cu. in. to cycle. One pint (28.875 cu. in.) of oil would cycle this control divider valve 401 times. The cycle monitor is

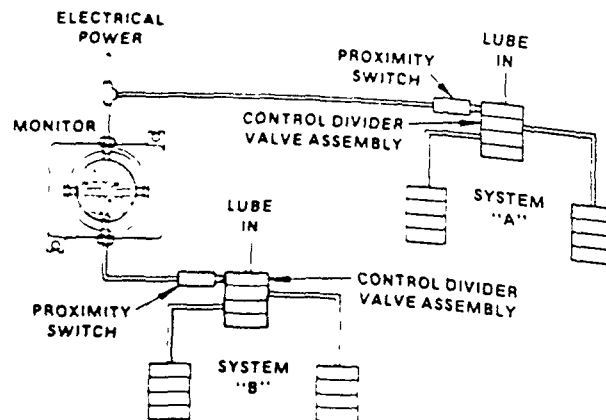

set to 401 by the three switches, units, tens and hundreds. The alarm switch is set to the predetermined time of 2 minutes, 40 seconds.

For every 401 proximity switch actuations the counter will register one, indicating one pint of oil. Concurrently, the amber L.E.D. will also turn on and off 401 times, indicating a signal has been received from the proximity switch.

If for any reason 2 minutes, 40 seconds passes without a proximity switch actuation, the cycle monitor will go into alarm. The red L.E.D. and alarm relay will turn on.

LINCOLN

One Lincoln Way St. Louis, Missouri 63120-1578
(314) 679-4200 Telex 44881

SECTION - M34

PAGE - 2

Figure 1

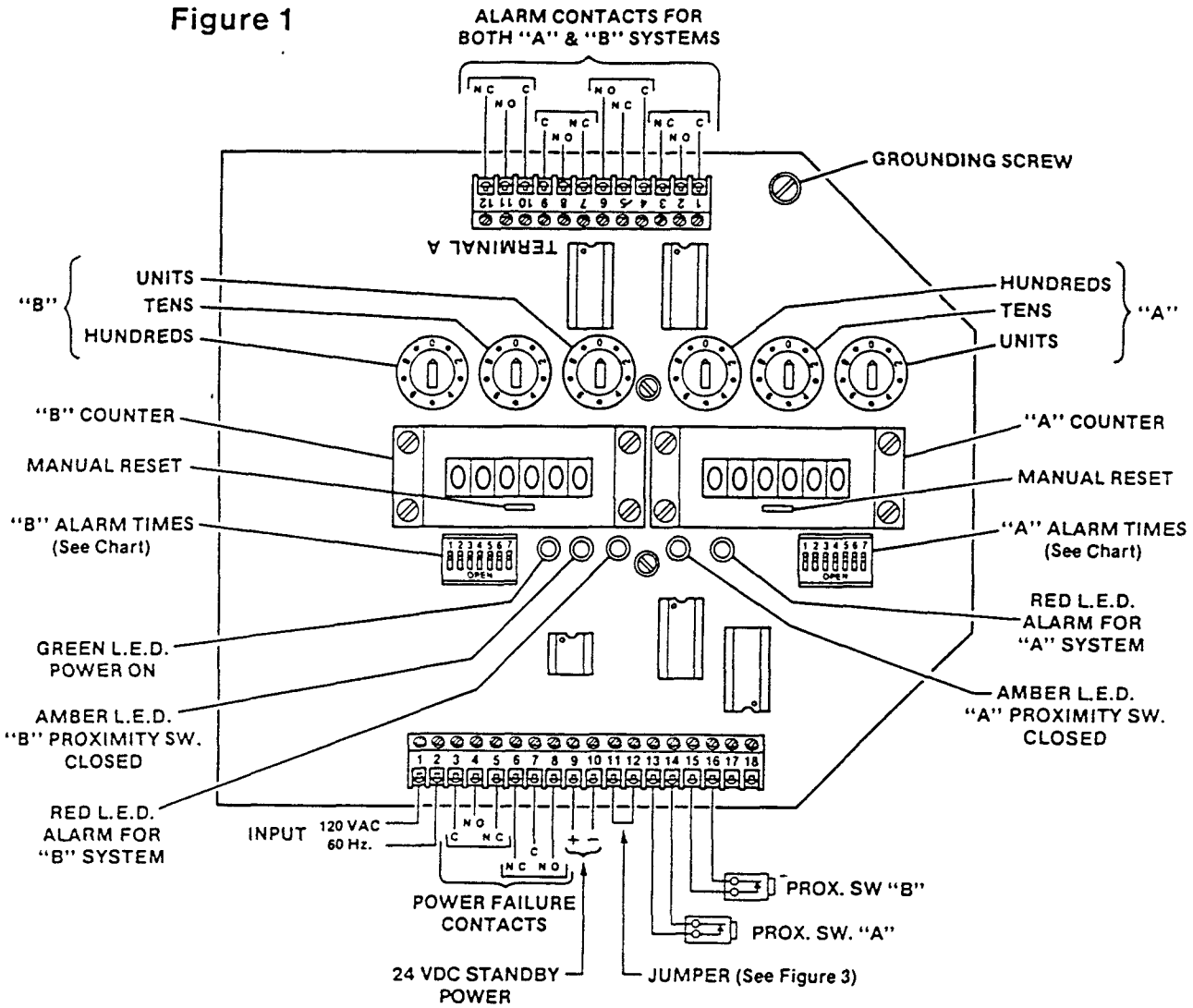

**PROXIMITY SWITCH
"A" TERMINALS 13 & 14
"B" TERMINALS 15 & 16**

**Figure 2
Alarm Lockout**

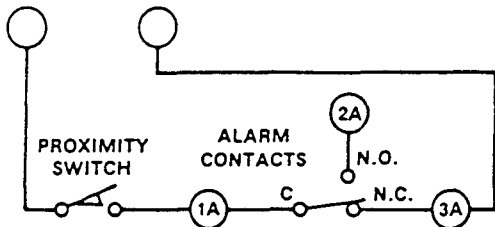

CONNECT ONE SIDE OF SWITCH TO PROX. SW. "A" OR "B" TERMINAL. CONNECT OTHER SIDE TO COMMON ALARM CONTACT. CONNECT N.C. ALARM CONTACT TO CORRESPONDING PROX. SW. TERMINAL. ALARM CONTACT TERMINALS 1A, 2A & 3A SHOWN, ANY SET OF ALARM CONTACTS MAY BE USED.

**Figure 3
Reset
Pushbutton**

REMOVE JUMPER AND INSTALL N.C. PUSH-BUTTON IF RESET IS NEEDED.

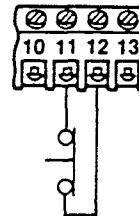

**Figure 4
Disables
"A" Alarm**

THE CLOSING OF A CONTACT WILL DISABLE "A" ALARM.

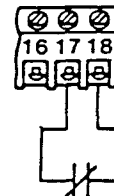

WIRE CONNECTIONS

Power must be off before making wiring connections or switch adjustments.

Power Source - Terminals 1 & 2 (120 VAC, 50 Hz. or 60 Hz.)

Power Failure Contacts (Rating: 1/10 HP, 3 Amps at 120 VAC) - Power failure relay is energized when power is on. No internal voltage is applied to power failure contacts. When a power failure occurs (120 VAC), power failure relay is de-energized and contacts transfer.

Terminal 3 - Common	Terminal 6 - Normally Closed
Terminal 4 - Normally Open	Terminal 7 - Common
Terminal 5 - Normally Closed	Terminal 8 - Normally Open

Backup Power Source (24 VDC Battery) - Terminal 9, Battery (+). Terminal 10, Battery (-). In the event a power loss occurs (120 VAC), the power failure contacts transfer to standby 24 VDC. A reset pushbutton must be used with 24 VDC backup power source to reset monitor after an alarm condition occurs.

Proximity Switch "A" (N.O. or N.C.) - Terminals 13 & 14.

Proximity Switch "B" (N.O. or N.C.) - Terminals 15 & 16.

Alarm Contacts (Rating: 1/10 HP, 3 Amps at 120 VAC) - Alarm relay is energized and contacts transfer only when system goes into alarm. No internal voltage is applied to alarm contacts.

Terminal 1A - Common	Terminal 7A - Normally Closed
Terminal 2A - Normally Open	Terminal 8A - Normally Open
Terminal 3A - Normally Closed	Terminal 9A - Common

Terminal 4A - Common	Terminal 10A - Common
Terminal 5A - Normally Closed	Terminal 11A - Normally Open
Terminal 6A - Normally Open	Terminal 12A - Normally Closed

Monitoring Only One System - Adding a jumper wire or closing a contact between Terminals 17 & 18 (See Fig. 4) will disable "A" alarm. System "B" will function normally.

Alarm Lockout - Connect proximity switch "A" or "B" to alarm contacts as shown in Figure 2. When an alarm condition occurs, system will go into alarm and stay in alarm until power is disconnected or reset pushbutton is depressed.

Reset Pushbutton - Terminals 11 & 12. Used to reset cycle monitor after an alarm condition occurs. Remove jumper wire and replace it with a normally closed pushbutton (See Fig. 3). Jumper wire must be used if a reset pushbutton is not used.

CYCLE MONITOR SETTINGS

Cycle Counter - Determine the number of times each divider valve system must cycle to dispense one pint of oil. The "A" and "B" proximity switches signal the cycle monitor once for each time their respective divider valves cycle. Setting the "A" and "B" Units, Tens and Hundreds switches accordingly will advance the "A" and "B" counters by 1 (indicating one pint) when their predetermined number of cycles are reached.

EXAMPLE: A divider valve system must cycle 150 times to dispense one pint of oil. Setting the Hundreds switch to 1, the Tens switch to 5 and the Units switch to 0 would require 150 proximity switch actuations to advance the counter by one.

Alarm Time Selection - "A" and "B" alarm time settings should be 25% longer than the time required for their respective divider valve systems to complete one cycle. Choose an appropriate time from the Alarm Time Selection Chart. Set "A" and "B" alarm times by closing only the switches indicated in the chart. Switches #1 & #2 are control switches. Switches #3 thru #7 must have one switch closed to set the alarm time.

Important: Control will not operate properly if none of the switches #3 thru #7 are closed or more than one switch #3 thru #7 is closed.

If either divider valve system does not cycle within its alarm time setting, system will go into alarm causing that system's Red L.E.D. to light and alarm relay to turn on.

Counter Manual Reset - Depressing the manual reset on the "A" and "B" counter will reset the counter back to zero. Do not depress manual reset if counter is energized.

NOTE: In some cases it may be necessary to use surge suppressors when inductive devices are controlled by the alarm relay or power failure relay. It is also recommended that shielded wire be used on all Input Output lines to reduce problems with electrical noise.

LIGHTS - L.E.D.

Green light indicates power is on.

Amber light "A": "on" proximity switch "A" closed,
"off" proximity switch "A" open

Amber light "B": "on" proximity switch "B" closed,
"off" proximity switch "B" open

Red light "A" indicates an "A" system alarm.

Red light "B" indicates a "B" system alarm.

ALARM TIME SELECTION CHART

ALARM TIME	SWITCH #1	SWITCH #2	CLOSE SWITCH #	ALARM TIME	SWITCH #1	SWITCH #2	CLOSE SWITCH #
8 Sec.	●	●	3	48 Sec.	OPEN	●	5
10 Sec.	●	OPEN	3	56 Sec.	OPEN	OPEN	5
12 Sec.	OPEN	●	3	1 Min., 4 Sec.	●	●	6
14 Sec.	OPEN	OPEN	3	1 Min., 20 Sec.	●	OPEN	6
16 Sec.	●	●	4	1 Min., 36 Sec.	OPEN	●	6
20 Sec.	●	OPEN	4	1 Min., 52 Sec.	OPEN	OPEN	6
24 Sec.	OPEN	●	4	2 Min., 8 Sec.	●	●	7
28 Sec.	OPEN	OPEN	4	2 Min., 40 Sec.	●	OPEN	7
32 Sec.	●	●	5	3 Min., 12 Sec.	OPEN	●	7
40 Sec.	●	OPEN	5	3 Min., 44 Sec.	OPEN	OPEN	7

● INDICATES SWITCH CLOSED.