

SPECIFICATIONS:

Max. Operating Pressure	Seal Material	Lube Inlet	Lube Outlets	Indicator Ports	Mounting Screw Torque	Tie Rod Nut Torque
3500 PSI	Nitrile	1/4-18 NPSF	1/8-27 NPSF	1/8-27 NPSF	80-100 in.-lbs.	80-100 in.-lbs.

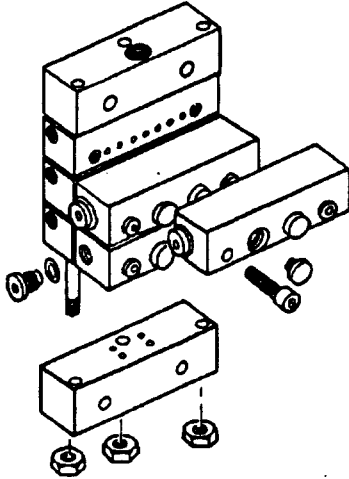

Description:

UV Divider Valves are comprised of three to eight valve blocks fastened to a segmented base plate with O-ring seals between the valve blocks and the baseplate and

the baseplate segments. These divider valves are a component part of a single line, progressive lubrication system and can be used for dispensing oil or grease. UV valves and baseplate segments are supplied with nitrile seals, however fluorocarbon elastomer (Viton) seals are available.

Refer to the Modular Lube Planning Manual for system design information and an in-depth explanation of operation. An in-line filter should be installed between the pump and divider valves. Check valves should be installed at the inlets of all bearing points. Refer to Service Manual Section M50 Page 1 for check valve information.

Valve blocks containing metering pistons discharge a predetermined amount of lubricant with each cycle. Valve blocks will have either single or twin outlets and may be externally crossported using

Model 87943 Crossport Bar. Whenever a single outlet divider valve or cross-port bar is used, the unused baseplate outlet(s) must be plugged. Use 68645 pipe plug.

An 882000 By-Pass Block can be used on any position on the base plate, as long as there are at least three other working divider valves on the baseplate. The bypass block allows the addition or deletion of lubrication points without disturbing existing piping. Both baseplate outlets under the bypass block must be plugged.

The valve blocks and bypass blocks are fastened to a baseplate mounted on the machine to be lubricated. The baseplate contains the divider valve's inlet and outlet connections, interrelated passageways, and built-in check valves. All piping of lubricant to and from the divider valves is connected to the baseplate.

UV VALVE BLOCKS

Divider Valve Stamping	Single	Twin	Cycle indicator pin (right)		Single (1 outlet) Discharge/Outlet	Twin (2 outlet) Discharge/Outlet
			Single	Twin		
UV-5	882051	882052	-	-	.010 CU. IN.	.005 CU. IN.
UV-10	882101	882102	-	-	.020 CU. IN.	.010 CU. IN.
UV-15	882151	882152	-	-	.030 CU. IN.	.015 CU. IN.
UV-20	882201	882202	882203	882204	.040 CU. IN.	.020 CU. IN.
UV-25	882251	882252	882253	882254	.050 CU. IN.	.025 CU. IN.
UV-30	882301	882302	882303	882304	.060 CU. IN.	.030 CU. IN.
UV-35	882351	882352	882353	882354	.070 CU. IN.	.035 CU. IN.
UV-40	882401	882402	882403	882404	.080 CU. IN.	.040 CU. IN.

UV BASEPLATES

Outlets	Inlet Block	Intermediate Blocks	End Blocks	Tie Rod Kit*
2 to 6	87918	[3] 87919	87920	250290
2 to 8	87918	[4] 87919	87920	250291
2 to 10	87918	[5] 87919	87920	250292
2 to 12	87918	[6] 87919	87920	250293
2 to 14	87918	[7] 87919	87920	250294
2 to 16	87918	[8] 87919	87920	250295

* Kit consists of 3 rods and 3 nuts

The baseplate consists of one inlet block, three to eight intermediate blocks, one end block, and a set of three tie rods and nuts. O-ring seals are installed into the intermediate and end blocks. The valve block capacity of each baseplate is dependent upon the number of intermediate blocks in the baseplate assembly. There must be a minimum of three working divider valves on each valve and baseplate assembly.

Cycle Indicator Pin Option:

Optional cycle indicator pins provide positive indication of system operation. The indicator pin is an extension of the piston in the valve block and will cycle in and out as the piston moves.

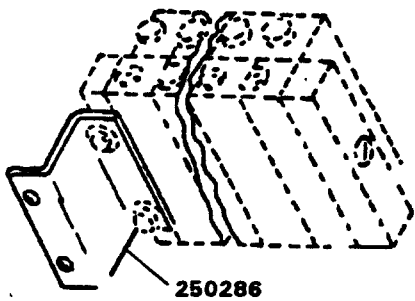

Optional Mounting Bracket installation.

Divider valves with cycle indicator pins are supplied by the factory with the indicator assemblies on the right hand side of the valve. If a left hand valve is required, the valves may be converted by disassembling the valve, reversing the piston in the valve bore, and reassembling by installing the indicator assembly on the left side of the valve.

Assembly Instructions:

1. Screw three tie rods into inlet block until they bottom out in hole.
2. Check each intermediate block to insure there are 9 O-rings securely installed in one face of each intermediate block.
3. Slide intermediate blocks onto the tie rods until the last intermediate block is in place. Face of intermediate block containing O-rings must be installed facing the inlet block end of the assembly.
4. Check end block to insure that there are 9 O-rings securely installed in one face of the end block.
5. Slide the end block, with O-ring face adjacent to the last intermediate block, over the tie rods.
6. Lay the baseplate assembly on a flat surface. Install the three 1/4-28 lock nuts at the end block end of the assembly. Torque the nuts to 80-100 in. lbs.

Operation:

The inlet passageway is connected to all piston chambers at all times with only one piston free to move at any one time. With all pistons at the far right, lubricant from the inlet flows against the right end of piston 1. (See illustration 1)

Lubricant flow shifts piston 1 from right to left dispensing piston 1 output through connecting passages to outlet 1. Piston 1 shift directs flow against the right side of piston 2. (See illustration 2)

Lubricant flow shifts piston 2 from right to left dispensing piston 2 output through valve ports of piston 1 and through outlet 2. Piston 2 shift directs lubricant flow against the right side of piston 3. (See illustration 3)

Lubricant flow shifts piston 3 from right to left dispensing piston 3 output through valve ports of piston 2 and through outlet 3. Piston 3 shift directs lubricant flow through connecting passage to the left side of piston 1. (See illustration 4)

Lubricant flow against the left side of piston begins the second half-cycle which shifts pistons from left to right dispensing lubricant through outlets 4, 5 and 6 of the divider valve.

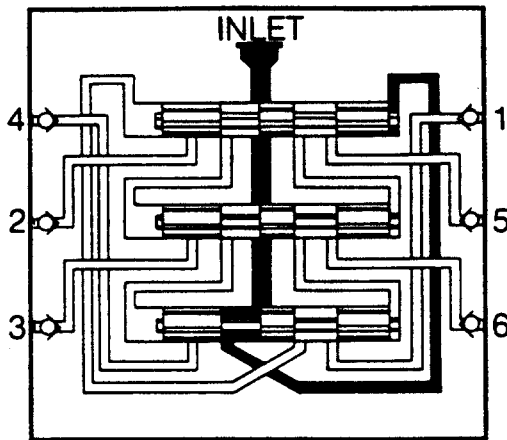

Illustration #1

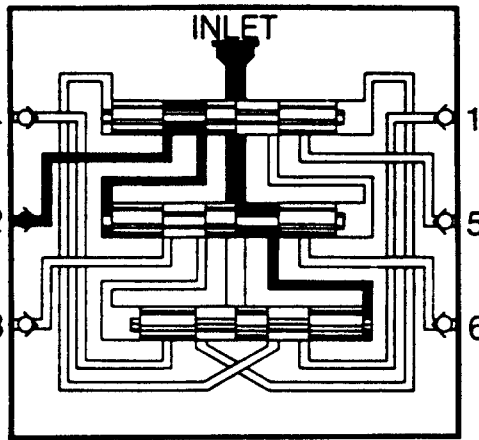

Illustration #3

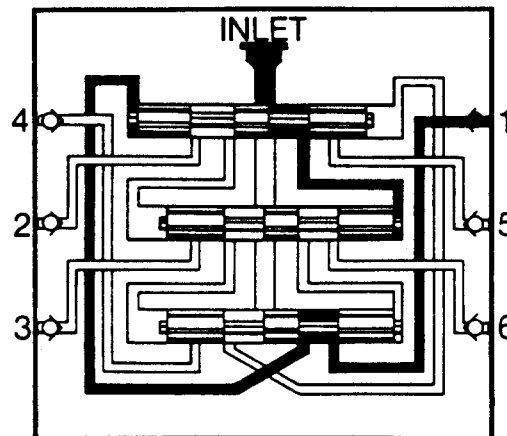

Illustration #2

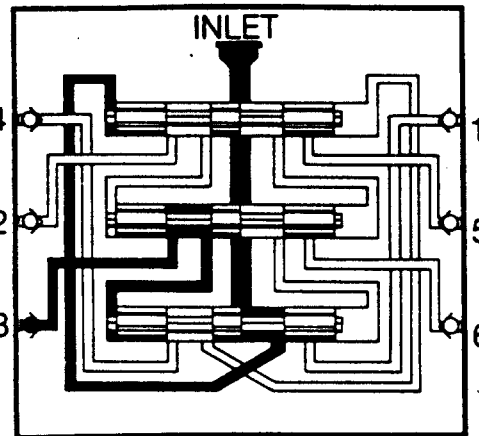
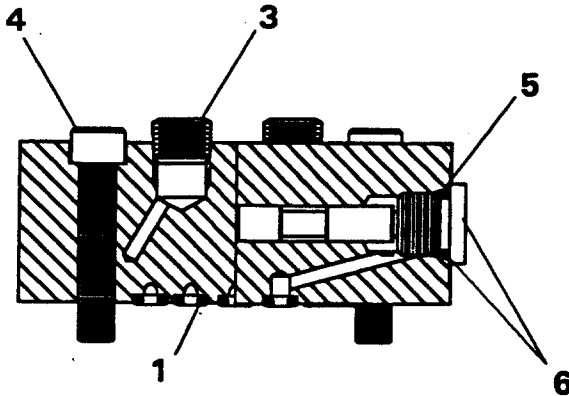
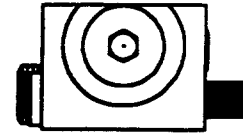
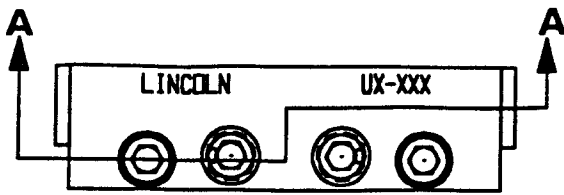
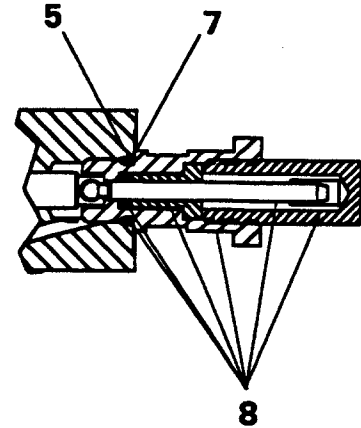

Illustration #4

M-50-14



SECTION A-A



CYCLE INDICATOR ASS'Y.
(Only divider valves which have cycle indicator pins installed)

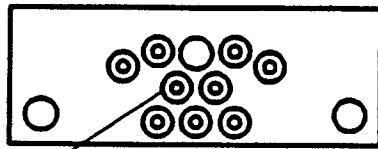

1

SECTION B-B

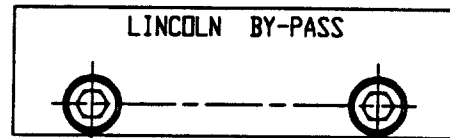
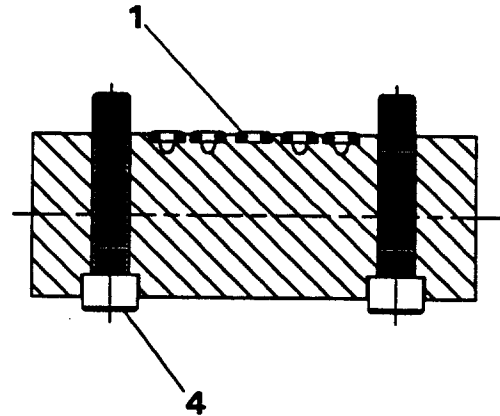

BY-PASS BLOCK ASS'Y
882000

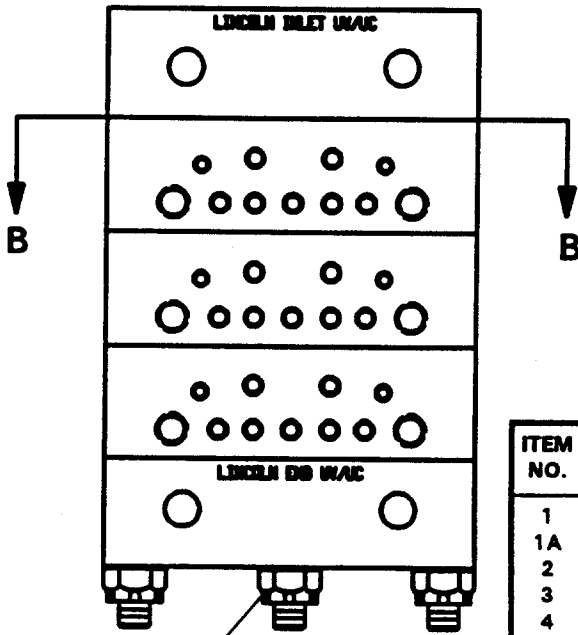

BASE PLATE ASSEMBLY

SERVICE PARTS

IN 50-14

ITEM NO.	DESCRIPTION	PKG. QUAN.	PART NO.
1	O-Ring (Nitrile)	20	250309
1A	O-Ring (Viton)	20	250310
2	Castellated Locking Nut	15	250323
3	Socket Hd. Pipe Plug (1/8-27 NPTF)	1	250324
4	Socket Hd. Cap Screw (1/4-28 X 1 1/4")	1	250333
5	O-Ring (Nitrile)	10	250318
5A	O-Ring (Viton)	10	250319
6	End Port Plug Ass'y. (Nitrile) (Incl. Item 5)	1	250316
6A	End Port Plug Ass'y. (Viton) (Incl. Item 5A)	1	250317
7	O-Ring (Nitrile)	10	250325
7A	O-Ring (Viton)	10	250326
8	Cycle Indicator Ass'y. (Nitrile) (Incl. Item 7)	1	250331
8A	Cycle Indicator Ass'y. (Viton) (Incl. Item 7A)	1	250332

DIMENSIONS

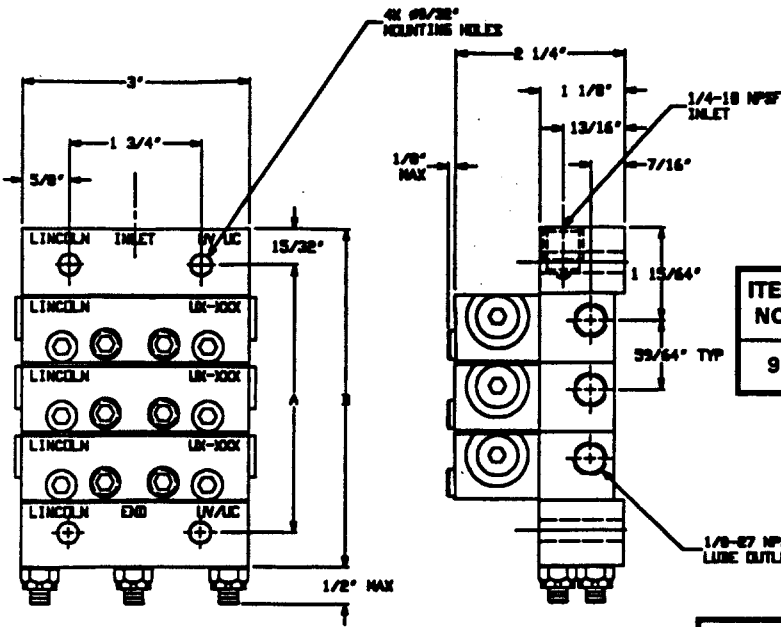

Outlets	A	B
2 to 6	3.58	4.52
2 to 8	4.50	5.44
2 to 10	5.42	6.36
2 to 12	6.34	7.28
2 to 14	7.27	8.20
2 to 16	8.19	9.13

ACCESSORIES

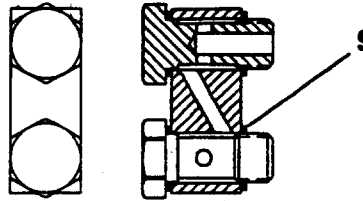

87943 CROSS PORT KIT

ITEM NO.	DESCRIPTION	PKG. QUAN.	PART NO.
9	Copper gasket	8	250315

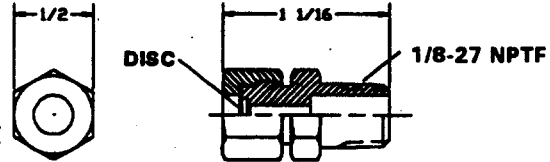

ATMOSPHERIC INDICATORS

Model No	Pressure	Repl. Disk *	Color
87934	1450 PSI	P/N 69813-10	Yellow
87935	1750 PSI	P/N 69813-12	Red
87936	3250 PSI	P/N 250312	Purple
87937	3700 PSI	P/N 250313	Yellow/Natural

*Packaged in quantities of 10

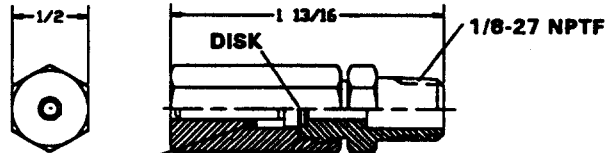

250334* PIN INDICATORS O-RING (Viton)

Model No	Pressure	Repl. Disk *	Color
87930	1450 PSI	P/N 69813-10	Yellow
87931	1750 PSI	P/N 69813-12	Red
87932	2650 PSI	P/N 250311	Pink
87933	3250 PSI	P/N 250312	Purple

*Packaged in quantities of 10

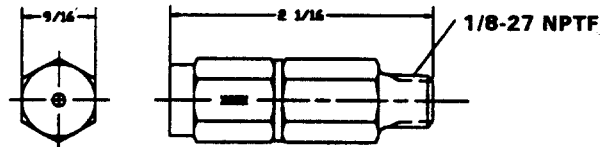

RESET INDICATORS

Model No	Pressure	Inlet
87938	500 PSI	1/8-27 NPTF
87939	1000 PSI	1/8-27 NPTF
87940	1500 PSI	1/8-27 NPTF
87941	2000 PSI	1/8-27 NPTF
87942	3000 PSI	1/8-27 NPTF

TYPICAL ACCESSORY INSTALLATION

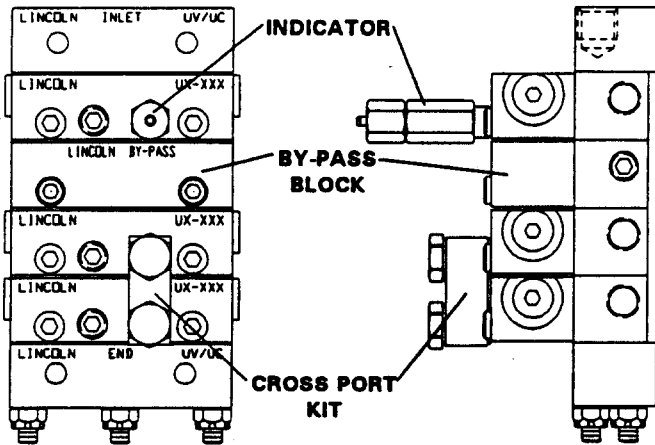

RETAIN THIS INFORMATION FOR FUTURE REFERENCE

When ordering replacement parts, list: Part Number, Description, Model Number, and Series Letter.

LINCOLN provides a Distributor Network that stocks equipment and replacement parts.

M50-