



Model No. 604265191
QUICKLUB® GREASE PUMP
 Series "A"

TYPE HP
MANUALLY OPERATED
SINGLE ACTING, SINGLE OUTLET

SPECIFICATIONS:

- Lubricant Output Per Stroke 0.1 cu. in. (1.6 cc)
- Max. Operating Pressure..... 2300 psi (160 bar)
- Reservoir Capacity 92 cu. in. (1.5 liters)
- Lubricant Outlet..... 1/4" O.D. Tube Connector
- Level Control Indicator Rod

DESCRIPTION

The 604265191 Pump is used in a progressive type centralized lubrication system. It is a single stroke, spring return pump that is manually operated. It has an indicator rod for visual inspection of reservoir grease level.

OPERATION

The pump is actuated by hand applying a smooth even force to the pump lever until it reaches its maximum travel. Relieve the downward force on the lever and it will return to its normal position by spring assistance.

IMPORTANT: Pump must be installed in a vertical position.

TO FILL RESERVOIR

It is recommended the reservoir be filled through the 5200 Lube Fitting located at the base of the reservoir, using an air operated or hand operated grease pump. Fill the reservoir until the recessed ring appears on the follower rod at the top of the reservoir.

TO PRIME SYSTEM

Pump & Supply Lines: After reservoir has been filled with recommended lubricant, loosen vent screw locknut and open vent screw approximately one turn (Do Not Remove). Also, loosen supply line fittings. Operate pump until lubricant flows from vent screw, then tighten vent screw and locknut. Continue to operate pump until lubricant flows from threads of any loosened fitting and tighten fitting. Repeat procedure until fittings are tightened and supply line is primed.

Feeder Lines: Fill each feeder line with lubricant before connecting to outlet of divider valve and bearing. This will prevent having to cycle each divider valve to fill line between divider valve and bearing.

TYPICAL DISTRIBUTION COMBINATIONS

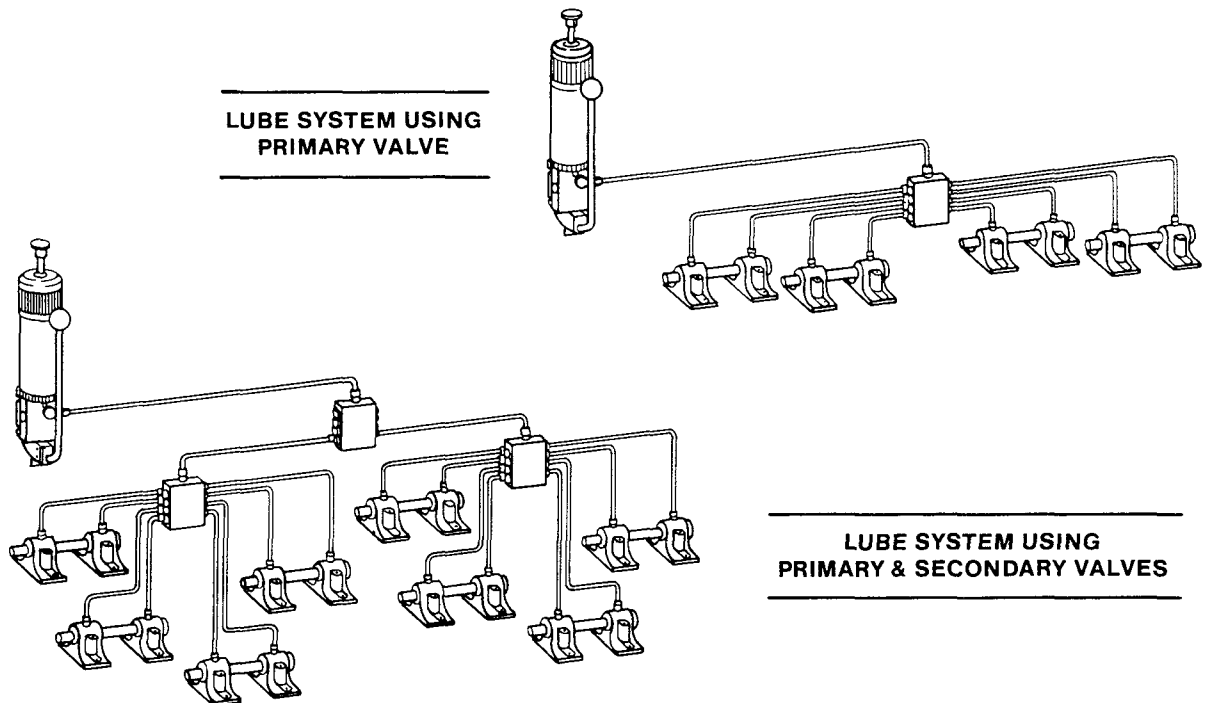

**Model 604265191
QUICKLUB® GREASE PUMP**

SERVICE PARTS

Part	Qty.	Description
5200	1	Lube fitting
201120183	3	Hex socket screw
207121358	1	Nut
207121383	1	Locknut
207124733	1	Seal locknut
209121466	1	Washer
209121581	3	Gasket (copper)
209121582	2	Gasket (copper)
211125041	2	Retaining ring
218124994	1	Spring
219122278	1	O-ring
219124514	1	O-ring
219124515	1	O-ring
220122404	1	Gasket
221124951	1	Knob
221124961	1	Knob
233130012	1	Steel ball
233130013	2	Steel ball
233130017	1	Check valve ball
300172362	1	Spring
300172381	1	Spring
300173232	1	Handle spring
302173762	1	Handle pin
303174983	1	Closure plug
303174992	1	Closure plug
304189891	1	Connector
306178313	1	Gasket
306178331	2	Gasket (paper)
310182893	1	Piston
404202352	1	Check seat
404202364	1	Compression nut
404202491	1	Reservoir
404202501	1	Reservoir cover
404202511	1	Follower guide rod
404202523	1	Follower piston
404202531	1	Follower plate
404202552	1	Gasket seat
404202861	1	Stop casing
404223541	1	Groove pin
404225812	1	Ferrule
404229331	1	Vent screw
504303251	1	Mounting bracket w/base
504303293	1	Handle
504303545	1	Pump body assembly

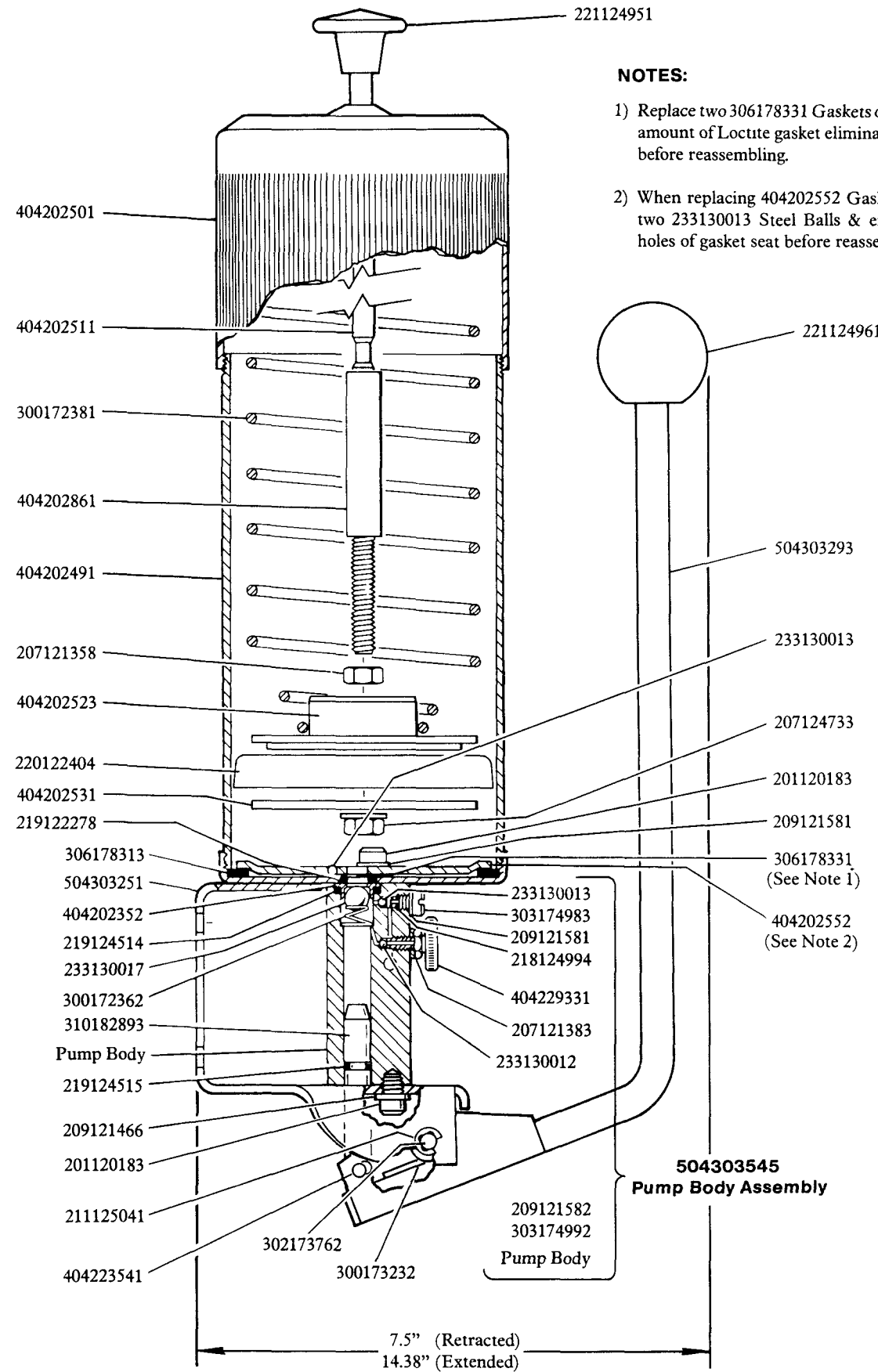

- NOTES:**
- 1) Replace two 306178331 Gaskets or apply a small amount of Loctite gasket eliminator to this area before reassembling.
 - 2) When replacing 404202552 Gasket Seat, order two 233130013 Steel Balls & embed in small holes of gasket seat before reassembling.

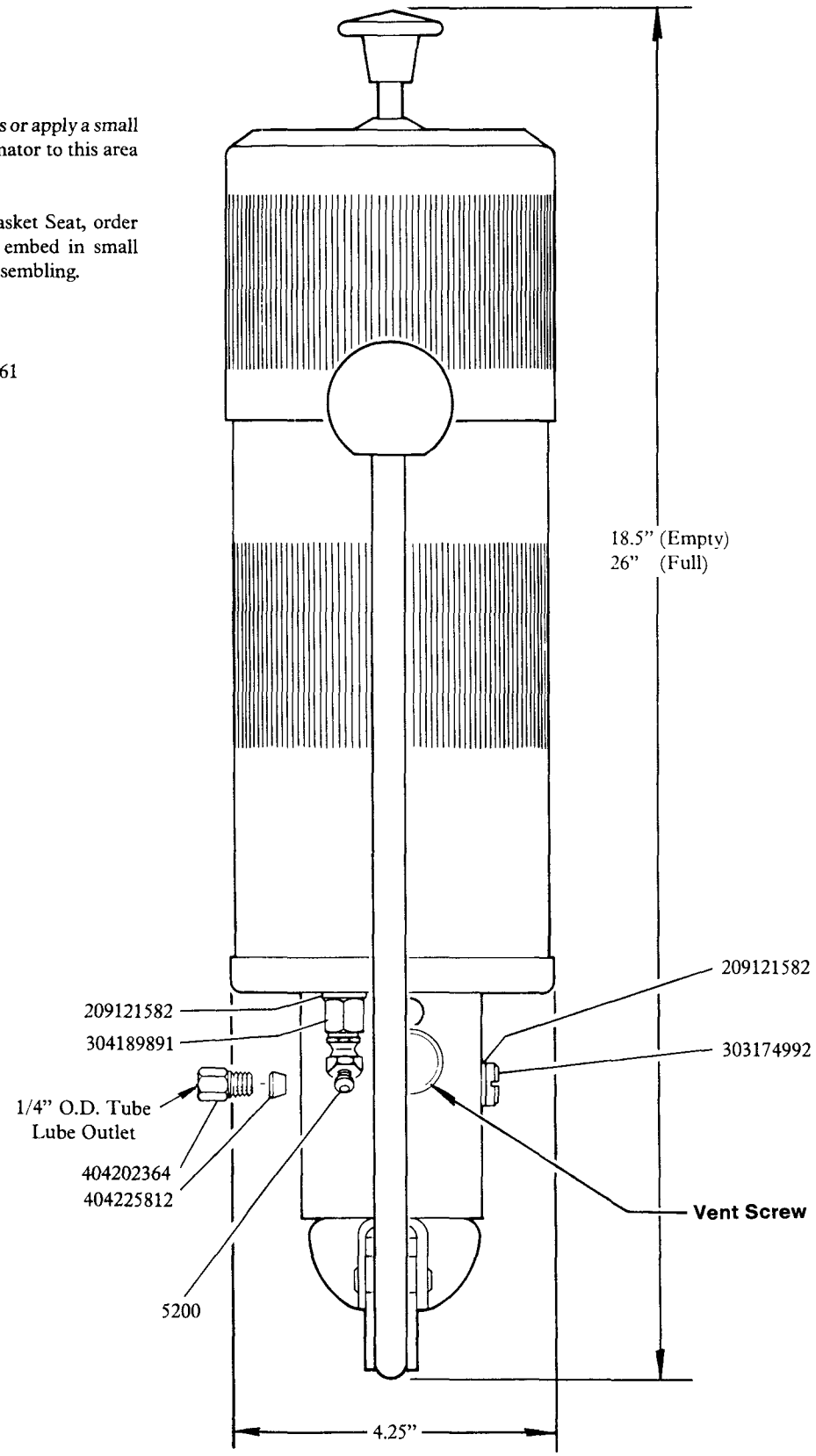

MOUNTING DIMENSIONS

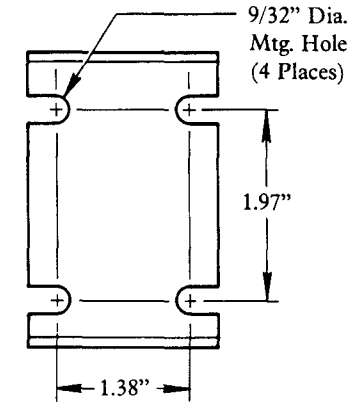

TROUBLESHOOTING

Problem	Solution
<p>1) Pump handle moves without resistance.</p> <p>2) Lubricant not delivered with pump stroke.</p>	<p>Pump is air locked - Vent air from the pump . Refer to instructions under To Prime System.</p> <p>Lubricant reservoir empty - Check lubricant level in reservoir and fill if necessary.</p>
<p>1) Unusual resistance felt in handle.</p>	<p>Blockage in delivery line - While maintaining slight pressure on handle, loosen fitting on pump body and check for lubricant delivery. Then loosen fittings at divider valves or at lubrication points until lubricant emerges from outlet to atmosphere and pump actuates. This will indicate in which line the blockage has occurred. Clear blockage or replace delivery line if damaged. Tighten all loose fittings.</p>
<p>1) Leakage between reservoir base and pump body.</p> <p>2) Lubricant not delivered with pump stroke.</p> <p>3) Handle moves without resistance.</p>	<p>219124514 O-ring is worn or damaged -</p> <p style="text-align: center;">or</p> <p>233130017 Check Valve Ball and 404202352 Check Seat dirty, worn or damaged - With reservoir empty, withdraw follower rod from top of reservoir and latch. Unscrew reservoir from reservoir base and remove. Unscrew two 201120183 Hex Socket Screws. Remove 211125041 Retaining Ring & 302173762 Handle Pin. Remove 504303293 Handle and 310182893 Piston assembled. Unscrew 201120183 Hex Socket Screw and remove pump body assembly. Remove 404202352 Check Seat & replace 219124514 O-ring. Clean & inspect 233130017 Check Valve Ball and 404202352 Check Seat, replace if worn or damaged. Replace 219122278 O-ring in reservoir base. To reassemble, reverse disassembly procedures. When installing piston, loosen vent screw locknut and open vent screw approximately one turn (Do Not Remove). After assembly, operate pump until lubricant flows from vent screw, then tighten vent screw and locknut.</p> <p>IMPORTANT: Pump body must be flush with reservoir base.</p>
<p>1) Leakage between reservoir and reservoir base.</p>	<p>306178313 Gasket is worn or damaged - With reservoir empty, withdraw follower rod from top of reservoir and latch. Unscrew reservoir from reservoir base and remove. Unscrew two 201120183 Hex Socket Screws. Remove 404202552 Gasket Seat. Replace 306178313 Gasket & two 306178331 Gaskets. To reassemble, reverse disassembly procedures.</p>
<p>1) Lubricant leaking from under pump body.</p>	<p>219124515 O-ring worn or damaged - Remove one 211125041 Retaining Ring, 302173762 Handle Pin and 300173232 Handle Spring. Remove handle and piston assembly from pump. Replace 219124515 O-ring. When installing piston, loosen vent screw locknut and open vent screw approximately one turn (Do Not Remove). Reassemble handle to pump with spring, pin and retaining ring. After assembly, operate pump until lubricant flows from vent screw, then tighten vent screw and locknut.</p>

RETAIN THIS INFORMATION FOR FUTURE REFERENCE

When ordering replacement parts, list: Part Number, Description, Model Number, and Series Letter.

LINCOLN provides a Distributor Network that stocks equipment and replacement parts.