

QUICKLUB® GREASE PUMP

Model 604265311

**TYPE PP
AIR OPERATED
SINGLE ACTING, SINGLE OUTLET**

Series "A"

SPECIFICATIONS:

Pump Ratio: 40:1
Air Pressure: 60 psi (4 bar) Min./100 psi (7 bar) Max.
Maximum Operating Pressure: 2900 psi (200 bar)
Lubricant Output/Cycle: 0.16 cu. in. (2.7 cc)
Air Inlet: 1/8" NPTF (Female)
Lube Outlet: 1/4" O.D. Tube Connector
Reservoir Capacity: 92 cu. in. (1.5 litre)

DESCRIPTION

The 604265311 Pump is used in a progressive type centralized lubrication system. It is an air operated, single stroke, spring return pump that requires the use of a 3-way air solenoid valve for the activation of the pneumatic cylinder. It has an indicator rod for visual inspection of grease level.

OPERATION

When the solenoid is energized, air pressure enters the bottom of the air cylinder and moves the piston and plunger upward. As the piston and plunger assembly moves upward the check valve ball seats preventing lubricant from returning to the reservoir. Lubricant is therefore dispensed from the outlet of the pump.

When the solenoid is de-energized, air pressure in the air cylinder is relieved. The piston spring moves the piston and plunger downward. The check valve ball unseats allowing lubricant from reservoir to refill the discharge cavity in the pump body block for the next lubrication cycle.

IMPORTANT: Pump must be installed in vertical position.

TO FILL RESERVOIR

It is recommended the reservoir be filled through the 5200 Lube Fitting located at the base of the reservoir, using an air operated or hand operated grease pump. Fill the reservoir until the recessed ring appears on the follower rod at the top of the reservoir.

TO PRIME SYSTEM

Pump & Supply Lines: After reservoir has been filled with recommended lubricant, loosen vent screw locknut and open vent screw approximately one turn (Do Not Remove). Also, loosen supply line fittings. Operate pump until lubricant flows from vent screw, then tighten vent screw and locknut. Continue to operate pump until lubricant flows from threads of any loosened fitting and tighten fitting. Repeat procedure until fittings are tightened and supply line is primed.

Feeder Lines: Fill each feeder line with lubricant before connecting to outlet of divider valve and bearing. This will prevent having to cycle each divider valve to fill line between divider valve and bearing.

TYPICAL DISTRIBUTION COMBINATIONS

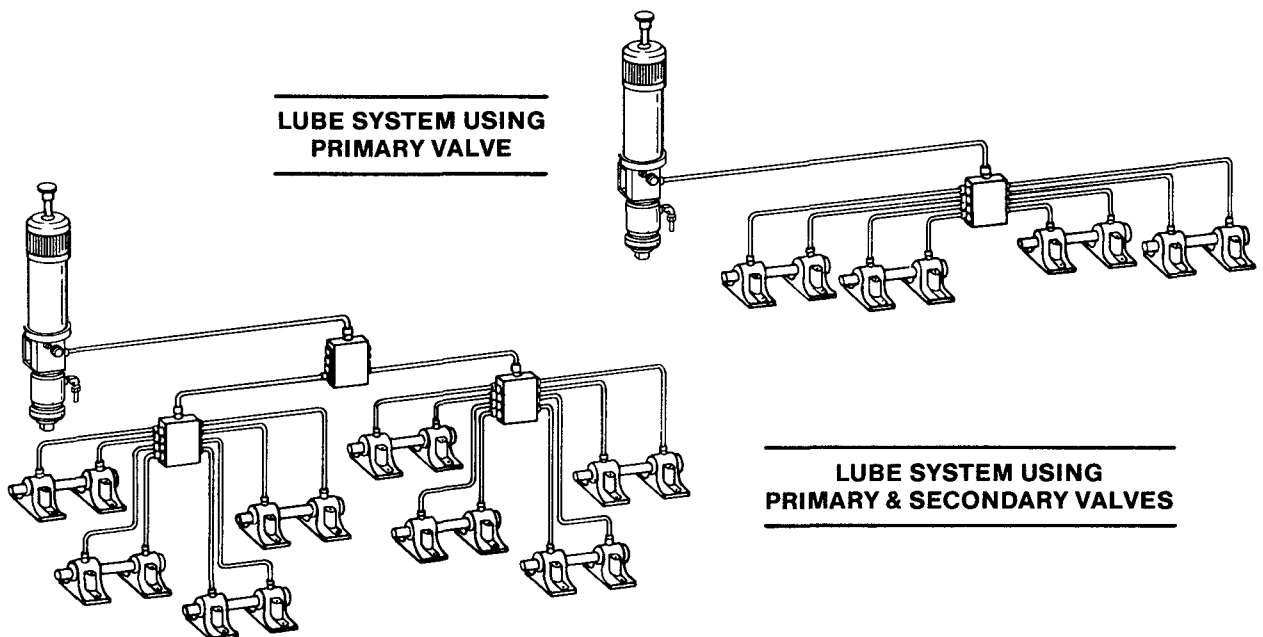

LINCOLN
A PENTAIR COMPANY

One Lincoln Way
 St. Louis, MO 63120-1578
 (314) 679-4200
 Customer Service, (314) 679-4300

SECTION - **Q2**
 PAGE - **1**

Model 60426531 1 QUICKLUB® GREASE PUMP

SERVICE PARTS

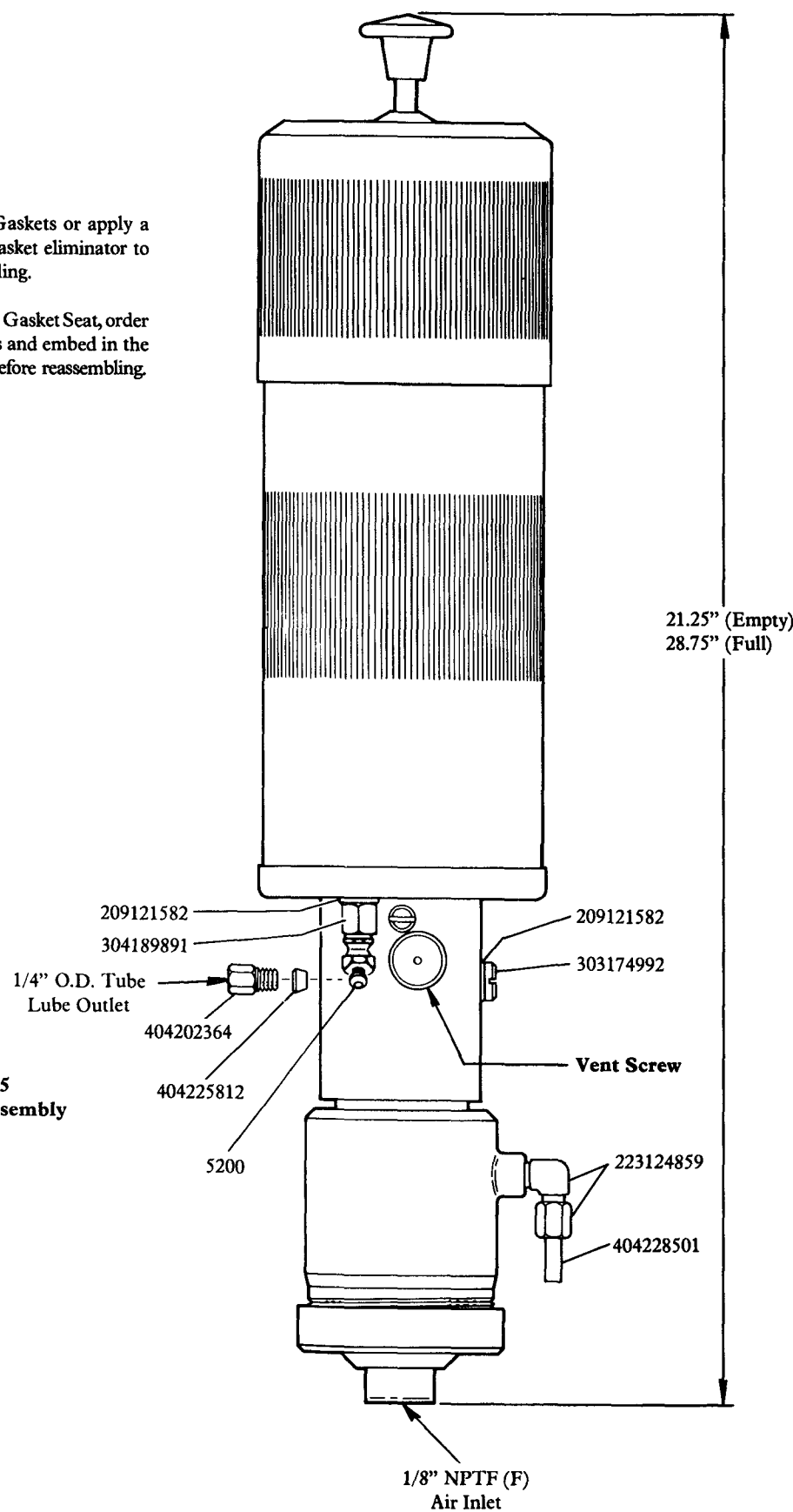
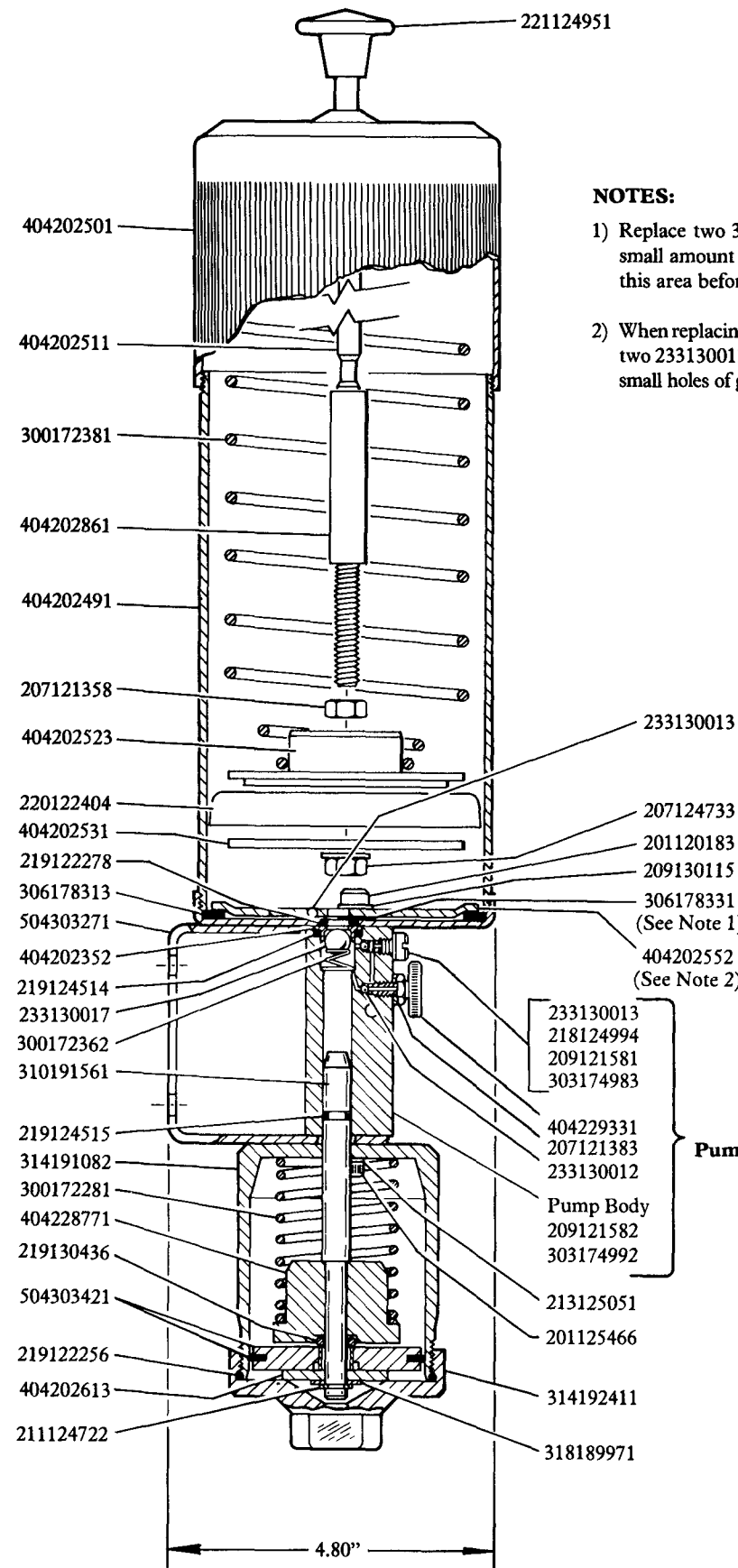

PART	QUAN.	DESCRIPTION
5200	1	Lube fitting
201120183	2	Hex socket screw
201125466	2	Hex socket screw
207121358	1	Nut
207121383	1	Locknut
207124733	1	Seal locknut
209121581	1	Gasket (copper)
209121582	2	Gasket (copper)
209130115	2	Washer
211124722	1	Retaining ring
213125051	2	Lockwasher
218124994	1	Spring
219122256	1	O-ring
219122278	1	O-ring
219124514	1	O-ring
219124515	1	O-ring
219130436	1	O-ring
220122404	1	Follower
221124951	1	Knob
223124859	1	Elbow
233130012	1	Steel ball
233130013	3	Steel ball
233130017	1	Check valve ball
300172281	1	Spring
300172362	1	Spring
300172381	1	Spring
303174983	1	Closure plug
303174992	1	Closure plug
304189891	1	Connector
306178313	1	Gasket
306178331	2	Gasket (paper)
310191561	1	Piston
314191082	1	Air cylinder
314192411	1	Air cylinder end cap
318189971	1	Washer
404202352	1	Check seat
404202364	1	Compression nut
404202491	1	Reservoir
404202501	1	Reservoir cover
404202511	1	Follower guide rod
404202523	1	Follower piston
404202531	1	Follower plate
404202552	1	Gasket seat
404202613	1	Washer
404202861	1	Stop casing
404225812	1	Ferrule
404228501	1	Vent tube
404228771	1	Stop
404229331	1	Vent screw
504303271	1	Mounting bracket w/base
504303421	1	Air piston w/packing
504303545	1	Pump body assembly

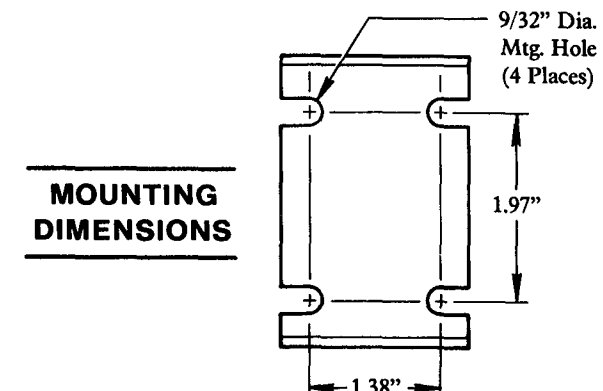

TROUBLESHOOTING

PROBLEM	SOLUTION
1) Pump actuates without delivering lubricant.	<p>Lubricant reservoir empty - Check lubricant level in reservoir and fill if necessary.</p> <p>Pump is air locked - Vent air from the pump. Refer to instructions under To Prime System.</p>
1) Pump does not actuate with air pressure to cylinder.	<p>Three-way solenoid inoperative - Check solenoid valve, repair or replace if necessary.</p> <p>Blockage in delivery line - With air supplied to the pump, loosen fitting on pump body and check for lubricant delivery. Then loosen fittings at divider valves or at lubrication points until lubricant emerges from outlet to atmosphere and pump actuates. This will indicate in which line the blockage has occurred. Clear blockage or replace delivery line if damaged. Tighten all loose fittings.</p>
1) Air escapes from air cylinder exhaust port with air cylinder activated and piston at top of stroke.	<p>219130436 O-ring or 504303421 Air Piston with Packing worn or damaged - Disconnect air supply. Unscrew 314192411 Air Cylinder End Cap. Remove piston assembly and disassemble all parts. Replace 219124515 O-ring, 219130436 O-ring, 504303421 Air Piston with Packing and 211124722 Retaining Ring. Reassemble piston assembly and lubricate lightly with oil. Loosen vent screw locknut and open vent screw approximately one turn (Do Not Remove) and install piston assembly. Replace 219122256 O-ring and reassemble air cylinder end cap to air cylinder. Reconnect air supply. Operate pump until lubricant flows from vent screw, then tighten vent screw and locknut.</p>
1) Grease discharged from air cylinder exhaust port.	<p>219124515 O-ring worn or damaged - Disconnect air supply. Unscrew 314192411 Air Cylinder End Cap. Remove piston assembly and replace 219124515 O-ring. Unscrew two 201125466 Hex Socket Screws and remove 314191082 Air Cylinder. Clean air cylinder and reassemble with two hex socket screws.</p> <p>NOTE: Before tightening, center air cylinder on bore hole of pump body.</p> <p>Lubricate piston assembly lightly with oil. Loosen vent screw locknut and open vent screw approximately one turn (Do Not Remove) and install piston assembly. Replace 219122256 O-ring and reassemble air cylinder end cap to air cylinder. Reconnect air supply. Operate pump until lubricant flows from vent screw, then tighten vent screw and locknut.</p>
1) Grease leaking between reservoir and reservoir base.	<p>306178313 Gasket is worn or damaged - With reservoir empty, withdraw follower rod from top of reservoir and latch. Unscrew reservoir from reservoir base and remove. Unscrew two 201120183 Hex Socket Screws. Remove 404202552 Gasket Seat. Replace 306178313 Gasket & two 306178331 Gaskets. To reassemble, reverse disassembly procedures.</p>
<p>1) Grease leaking between pump body and reservoir base.</p> <p>2) Pump actuates without delivering lubricant.</p>	<p>219124514 O-ring or 219122278 O-ring worn or damaged - or</p> <p>233130017 Check Valve Ball and 404202352 Check Seat dirty, worn or damaged -</p> <p>Disconnect air supply. Unscrew 314192411 Air Cylinder End Cap. Remove piston assembly and replace 219124515 O-ring. Unscrew two 201125466 Hex Socket Screws and remove 314191082 Air Cylinder. With reservoir empty, withdraw follower rod from top of reservoir and latch. Unscrew reservoir from reservoir base and remove. Unscrew two 201120183 Hex Socket Screws and remove pump body assembly. Remove 404202352 Check Seat and replace 219124514 O-ring. Clean & inspect 233130017 Check Valve Ball and 404202352 Check Seat, replace if worn or damaged. Replace 219122278 O-ring in reservoir base. To reassemble, reverse disassembly procedures. When installing piston, loosen vent screw locknut and open vent screw approximately one turn (Do Not Remove). Replace 219122256 O-ring and reassemble air cylinder end cap to air cylinder. Reconnect air supply. Operate pump until lubricant flows from vent screw, then tighten vent screw and locknut.</p> <p>IMPORTANT: Pump body must be flush with reservoir base.</p>

RETAIN THIS INFORMATION FOR FUTURE REFERENCE

When ordering replacement parts, list: Part Number, Description, Model Number, and Series Letter.

LINCOLN provides a Distributor Network that stocks equipment and replacement parts.

A list of Authorized Service Departments will be furnished upon request.