

OWNER/OPERATOR MANUAL

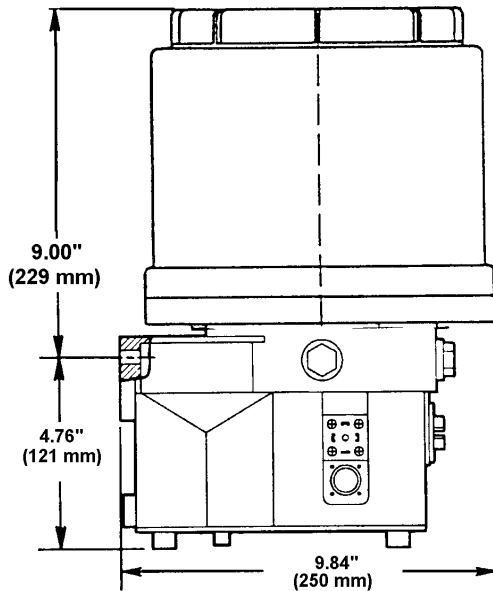

© Indicates Change

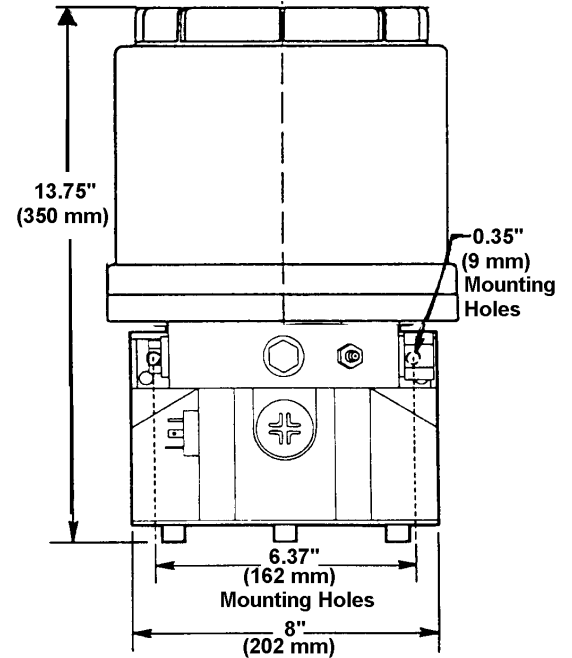

WARNING
Do not use pump without pressure relief valve.

SPECIFICATIONS

Electrical Requirements

- Model 94425 24 VDC @ 2 amps
- Enclosure Rating IP 6K9K - Protected from water sprayed in all directions.
- Timer..... 3.75 minutes "Off" time and 30 minutes "On" time.
- Pump Output244 in³/min. (4 cc/min)
- Outlet Connection 1/8" NPT (female)
- Maximum Recommended
 - Operating Pressure 3600 psi (248 bar)
 - Reservoir Capacity 244 cu. in. (4000 cc)
 - Lubricant..... Greases up to NLGI grade 2 (depending on the operating temperature and type of lubricant)
- Temperature Range..... - 13°F(-25°C) to +158°F(+70°C)
- Pressure Relief Valve 4000 psi +/- 250 psi (276 bars) +/- (17 bars)

DESCRIPTION

The chassis lube pump is electrically operated and used in a progressive type centralized lubrication system. The pump consists of a pump housing, electric gear motor, a timer and

a plastic reservoir with stirring paddle. The high operating pressure allows the pump to supply lubricant up to NLGI #2 grease. **NOTE:** Pump element especially designed for Hammer Paste Lubricant.

MOUNTING THE PUMP

Select an easily accessible place of installation which allows access to the timer and lubricant reservoir filler fitting. The pump must be mounted vertically on an even surface by means of three bolts.

TO FILL RESERVOIR

Fill the reservoir through the grease fitting located at the base of the reservoir, using a hand operated grease pump. Refill reservoir when grease reaches "MIN" mark located on the reservoir. Fill the reservoir up to the "MAX" mark located on the reservoir.

TO PRIME SYSTEM

Pump & Supply Line: After reservoir has been filled with recommended lubricant, loosen the supply line fitting. Operate the pump until lubricant flows from outlet, then tighten fitting.

Feed Lines: Pre-fill each feed line with lubricant before connecting to outlet of divider valve and bearing.

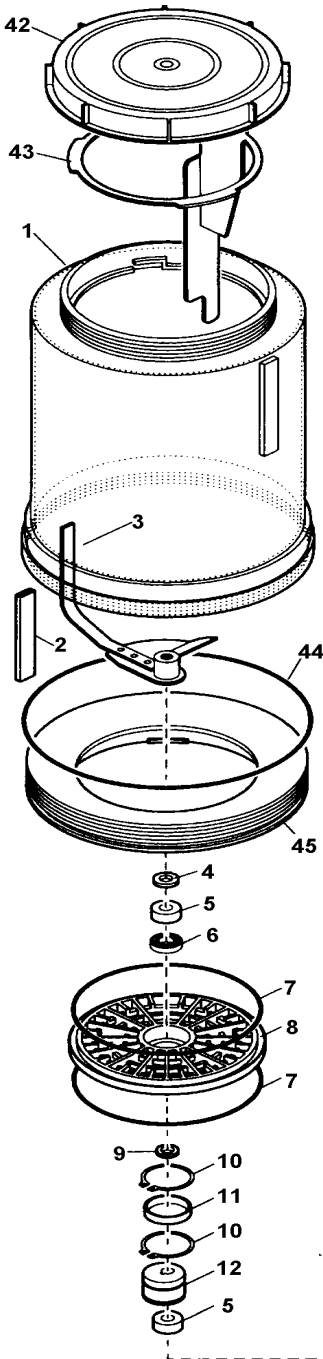

Description	Qty.	Part No.
8 amp fuse	1	241052
8 amp fuse holder	1	241053
Lighted manual switch (24 VDC)	1	241484
Remote manual lube kit	1	246322

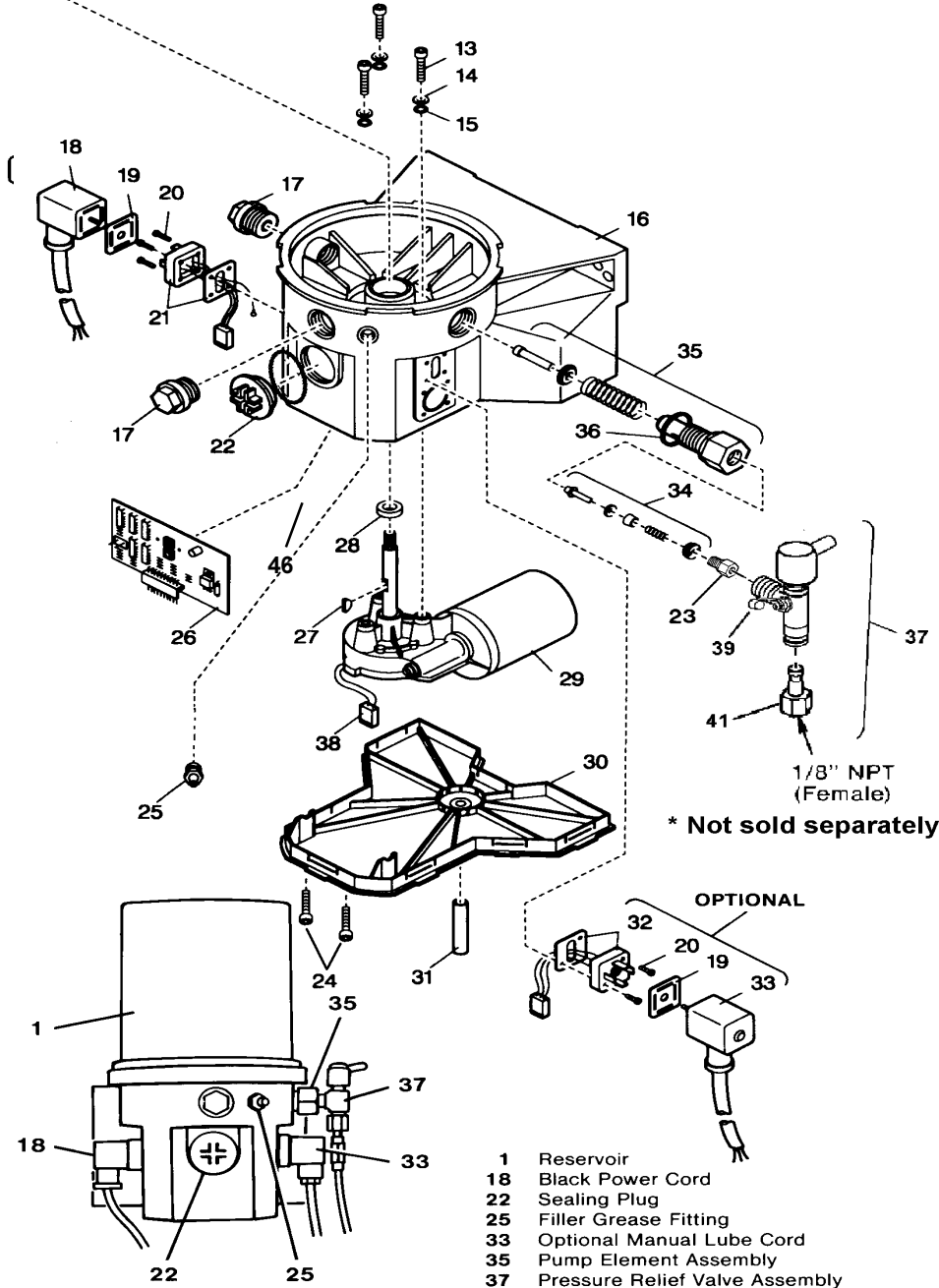

- 1 Reservoir
- 18 Black Power Cord
- 22 Sealing Plug
- 25 Filler Grease Fitting
- 33 Optional Manual Lube Cord
- 35 Pump Element Assembly
- 37 Pressure Relief Valve Assembly

ELECTRICAL CONNECTIONS

Connect black power cord as follows:

Red wire connects to Off/On switch, to 8 amp fuse then to Battery (+).

White wire connects to Battery (-).

Blue wire connects to 8 amp fuse, to ignition switch, then to Battery (+).

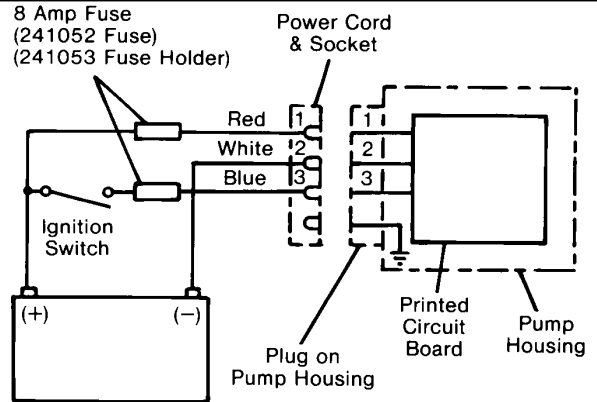

PARTS LIST

ITEM NO.	DESCRIPTION	QTY.	PART NUMBER /KIT NUMBER
1	Reservoir	1	247673
2	Hose	1	247676
3	Stirring paddle	1	247675
4	Washer	1	247679
5	Bearing ring	2	part of kit 246434
6	Bearing	1	part of kit 246434
7	O-ring	2	246424
8	Intermediate plate	1	246425
9	Shim	1	part of kit 246434
10	Snap ring	2	part of kit 246434
11	Inner ring	1	part of kit 246434
12	Eccentric cam	1	246427
13	Screw	3	part of kit 246436
14	Washer	3	part of kit 246436
15	O-ring	3	part of kits 246436 & 246437
16	Pump housing	1	246426
17	Closure plug	2	246422
18	Socket with cord	1	part of kit 246429
19	Flat packing	1	part of kits 246429, 246440, 246441, & 246431
20	Screws	4	part of kits 246440 & 246441
21	Plug	1	part of kit 246440
22	Sealing plug	1	246423
23	Nipple	1	226141055
24	Screw	10	206137967
25	Grease fitting	1	5050
26	Printed circuit board	1	246420
27	Woodruff key	1	part of kit 246436
28	Radial seal	1	part of kits 246436 & 246437
29	24 VDC motor	1	part of kit 246436
30	Housing cover	1	246421
31	Hose	1	not sold
32	Plug	1	part of kit 246441
33	Socket	1	part of kit 246431
34	Check valve	1	part of kit 600287501
35	Pump element	1	part of kit 600287501
36	Gasket	1	part of kit 600287501
37	Pressure relief assembly	1	270864©
38	Plug for motor	1	part of kit 246436
39	Grease cap	1	242125
41	Adapter for relief assembly	1	249565
42	Lid	1	247671
43	Fixed paddle	1	247664
44	O-ring	1	247677
45	Adapter	1	247678
46	O-ring	1	219141382

REMOTE MANUAL LUBE PUSHBUTTON

If a remote manual lube pushbutton is required, order a 246322 Manual Lube Kit (consisting of a 32 ft. cord and plug) and 241484 - Lighted Manual Lube Switch.

IMPORTANT:

When using a Model 94425 to replace an old style 103 pump with remote manual lube switch, only the 246322 Manual Lube Kit is required.

The wiring for the remote light used on the 103 pump must be changed for the new Model 94425. The existing wire that connects the light to the Battery (-) must be disconnected. Reconnect it to the Battery (+).

MOUNTING HOLE LOCATIONS

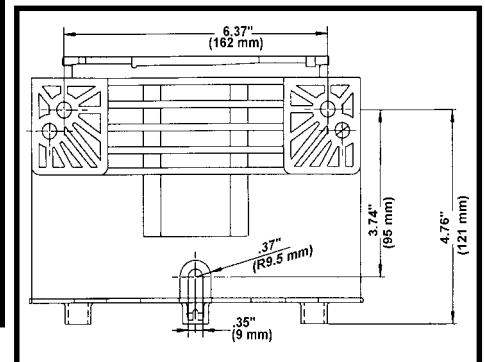

Fig. 1

TIMER OPERATION

The "Off" timer begins accumulating time when the ignition switch closes. When the "Off" timer reaches the preset value, the pump will turn on. The pump remains activated for the period of time that is preset on the "On" timer.

When the ignition switch opens, the "Off" timer will retain its accumulated time for a period of five days. When the ignition switch closes during the five day period, the "Off" timer will resume timing from the accumulated time it reached prior to the ignition switch opening. If ignition switch is not closed before the end of five day period, timer will begin with an "On" period.

Remove Sealing Plug (item 22) to access manual lube switch or to view the system LEDs.

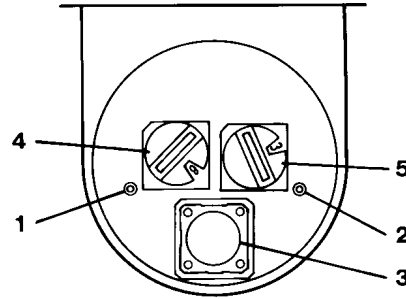

1. The LED marked "battery" lights when power is applied to the PC board.
 2. The LED marked "motor" lights when pumping lubricant.
 3. Depressing pushbutton for 2 seconds will initiate a manual lube event.
 4. "Off" time rotary switch, factory set to 3.75 minutes.
 5. "On" time rotary switch, factory set to 30 minutes.
- NOTE:** Do not change settings of "Off" or "On" time rotary switches.

SERVICE PARTS/KITS

Part No.	Qty.	Description	Item No.
249568	1	Grease fitting	40
5050	1	Grease fitting	25
242125	1	Grease cap	39
270864©	1	Pressur relief assembly	37
246420	1	Printed circuit board	26
246421	1	Housing cover	30
246422	1	Closure plug	17
246423	1	Sealing plug	22
246424	2	O-ring	7
246425	1	Intermediate plate	8
246426	1	Pump housing	16
246427	1	Eccentric cam	12
249565	1	Adapter for relief assembly	41
246429		Power Cord Kit contains:	
	1	Socket with cord	18
	1	Flat packing	19
246431		Optional Manual Lube Cord Set contains:	
	1	Flat packing	19
	1	Socket with cord	33
246434		Bearing & Seal Kit contains:	
	1	Washer	4
	2	Bearing ring	5
	1	Bearing	6
	1	Shim	9
	2	Snap ring	10
	1	Inner ring	11
246436		24 VDC Motor Kit contains:	
	3	Screw	13
	3	Washer	14
	3	O-ring	15
	1	Woodruff key	27
	1	Radial seal	28
	1	24 VDC motor	29
	1	Plug for motor	38

Part No.	Qty.	Description	Item No.
246437		Housing Seal Kit contains:	
	3	O-ring	15
	1	Radial seal	28
246440		Power Plug Kit contains:	
	1	Flat packing	19
	4	Screws	20
	1	Plug	21
246441		Optional Manual Lube Plug Set contains:	
	1	Flat packing	19
	4	Screws	20
	1	Plug	21
247664	1	Fixed paddle	43
247671	1	Lid	42
247673	1	Reservoir	1
247675	1	Stirring paddle	3
247676	1	Hose	2
247677	1	O-ring	44
247678	1	Adapter	45
247679	1	Washer	4
219141382	1	O-ring	46
226141055	1	Nipple	23
206137967	10	Screw	24
600287501		Pump Element Assembly contains:	
	1	Check valve	34
	1	Pump element	35
	1	Gasket	36
249569	1	Seal	4

© Indicates Change

Americas:
One Lincoln Way
St. Louis, MO 63120-1578
USA
Phone +1.314.679.4200
Fax +1.800.424.5359

Europe/Africa:
Heinrich-Hertz-Str 2-8
D-69183 Walldorf
Germany
Phone +49.6227.33.0
Fax +49.6227.33.259

Asia/Pacific:
25 Int'l Business Park
#01-65 German Centre
Singapore 609916
Phone +65.562.7960
Fax +65.562.9967



© Copyright 1999
Printed in USA
Web site:
www.lincolnindustrial.com