

## ***Lubrication System QLS 321 for Trailers/Semitrailers***



Subject to modifications

810-55251-1

## Table of Contents

<b>Safety Instructions</b> .....	<b>2</b>	<b>Setting and Operation of the QLS 321</b> .....	<b>13</b>
<b>Installation Instructions</b> .....	<b>3</b>	Display mode .....	13
Pump .....	3	Operating mode .....	14
SSV Divider Block .....	3	Programming mode .....	16
Crossporting of the SSV Divider Block .....	3	<b>Maintenance, Repair and Tests</b> .....	<b>17</b>
Check valves .....	4	Maintenance .....	17
Feedback of supplied lubricant .....	4	Refilling of reservoir .....	17
Lubrication point .....	4	Repair .....	17
Installing Quickline-tube fittings .....	4	Functional test .....	17
Installing Zerk-Locks onto grease fittings .....	4	<b>Troubleshooting</b> .....	<b>18</b>
Connecting feed lines .....	5	<b>Technical Data</b> .....	<b>21</b>
Filling of reservoir .....	5	Dimensions .....	22
QLS 321 selection guide .....	6	Option for metrical fittings .....	23
Electrical Connection Diagrams .....	7	<b>Service parts of the QLS 321</b> .....	<b>24</b>
<b>Description of QLS 321</b> .....	<b>7</b>	Manufacturer's declaration .....	26
<b>Operating of QLS 321</b> .....	<b>8</b>		
Flexible time of availability - operating time .....	9		
Flexible time of availability .....	9		
Operating time .....	10		
Pressure relief valve .....	10		
Display window of the key pad .....	10		
Low-level control .....	11		
Malfunction .....	12		

- Explanation of symbols:**
- = explanation
  - \* = describes an action
  - = listing within a section

## Safety Instructions

### Appropriate Use

- Use QLS 321 only for dispensing lubricants. QLS 321 is designed for intermittent operation only. QLS 321 is designed for supplying lubricant to a **maximum of 18 lube points per cycle**.

### General Safety Instructions

- QLS 321 Lubrication systems
    - are state of the art
    - can be assembled for safe operation.
  - Refill QLS 321 with clean lubricant.
  - Do not over pressurize reservoir when filling the pump.
  - Each outlet needed must be equipped with an appropriate check valve.
- Important:** Do not paint pump. Before painting a commercial vehicle make sure to either remove or completely cover the pump.
- Unauthorized modifications or changes to an installed system are not recommended and will void warranty. Any modifications must be subject to prior consultation with the manufacturer of the lubrication system or the manufacturer's contract partner.

### Regulations for prevention of accidents

- To prevent accidents, observe all city, state and federal safety regulation of the country in which the product will be used.

### Operation, Maintenance and Repair

- Repairs should only be performed by authorized personnel who are familiar with the instructions.

- QLS 321 must only operate with mounted or connected SSV divider blocks.
- QLS 321 must be regularly refilled with clean lubricant.
- QLS 321 operates automatically. However, a regular check (approx. every 2 weeks) should be made to ensure that lubricant is being dispensed from all lube points.
- Used or contaminated lubricants must be disposed of in accordance with local environmental regulations, see technical data sheets of lubricants used.
- The manufacturer of the centralized lubrication system will not accept any liability for
  - damage caused by insufficient lubricant and irregular refilling of pump
  - damage caused by inadequate or only conditionally pumpable lubricants
  - damage due to the use of contaminated lubricants.
  - damage caused by the inadequate disposal of used or contaminated lubricants.
  - damage caused by unauthorized modification of system components.
  - damage caused by the use of unapproved parts (voids the pump warranty).

**Installation**

- Do not remove, modify or alter any safety equipment already installed on the vehicle.
- QLS 321 must be kept away from sources of heat. (See Operating Temperature Specification).
- Use only original QLS 321 service parts (see Service Parts of the QLS 321) or parts approved by LINCOLN.
- Adhere to:
  - the installation instructions of the vehicle manufacturer as regards all drilling and welding procedures,
  - the specified minimum distances between the bore holes and the upper/lower rim of the frame or between two bore holes.
- Keep feed lines to each lube point as short as possible.
- Provide access to fill, clean and visually monitor the pump operation.

**Installation Instructions**

**Pump**

- Use drilling template to mark and drill mounting holes of the QLS 321. Drilling template and mounting bolts are included in the package of the QLS 321.

**SSV Divider Block**

**Crossporting of the SSV divider blocks**

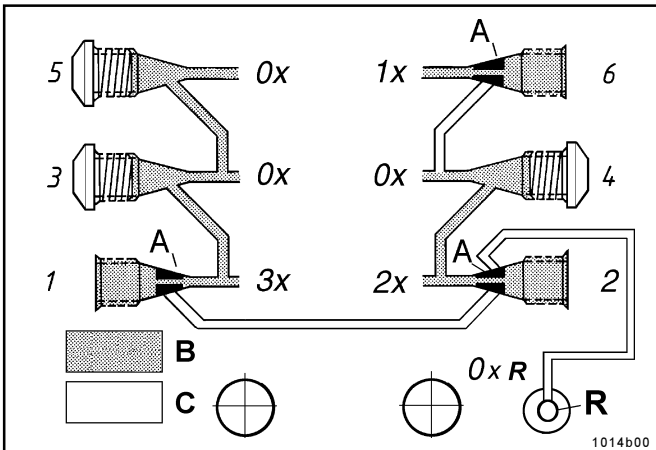

- The single output is the quantity of lubricant supplied to a lube point by a piston per stroke and per outlet bore hole. **It amounts to approx. 0.2 cm<sup>3</sup>.**
- By closing outlet bore holes with closure plugs (also part of the package) the amount of lubricant for a particular outlet can be increased.
- Lubricant from a plugged outlet is redirected to the next outlet on the same side of the SSV divider block in descending numerical order.
- For instance, plugging outlets 5 and 3 will triple the amount of lubricant at outlet 1.
- Unneeded lubricant quantities can be returned to the reservoir, see Return of Lubricant Quantities.

Fig. 1 - Single, double and triple lubricant output

- x - Outlet quantity (single, double, etc.)
- 1...6 Outlet numbers
- A - Clamping ring (brass)
- B - Grease supply
- C - Grease enclosed
- R - Return



Fig. 2 - Closure plug, provided in the accessory kits

\* Install a closure plug in each outlet bore hole which is not required (see fig. 1 or 4).

Subject to modifications

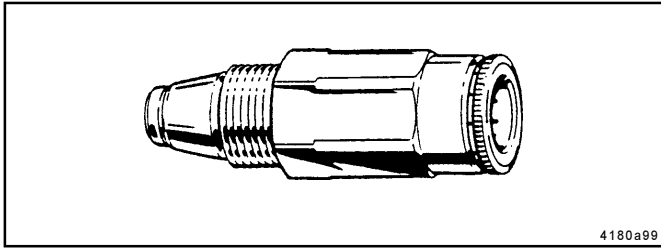

Fig. 3 - Check valve, push-in type

**Check valves**

- \* Install one complete check valve in each outlet bore hole which will be used.
- For pressure plastic tubes ( $\varnothing$  6x1.5 mm; 1/ 4 in.) use check valves with standard collar and knurled flange.

**Return of lubricant**

- QLS 321 with **back mounted SSV divider block** (vertical outlets) have the capability to **internally** feed back unneeded lubricant directly from the divider block to the reservoir.
- This happens automatically if **outlet 2** is closed with a closure plug (fig. 4). Lubricant quantities from **even and odd outlets can be fed back to the reservoir by combining the outlets 1 and 2**.
- To feed back lubricant, always start with the lowest outlet numbers, for instance, 2, 4, 6... or 1, 3, 5 ... **plus outlet 2**. Fig. 4 shows how the lubricant quantities of outlets 1, 2 and 4 (3xR) return to the reservoir.
- The remaining outlets are to be used for the connection to the lube point or to increase the lubricant quantity (double or triple).

Maximum of internally combinable outlets:

- SSV 6 = 3
- SSV 12 = 6
- SSV 18 = 9

**Important:** If **outlet 2** is connected to a **lube point**, then **outlet 1 must not be closed** (see fig. 1).

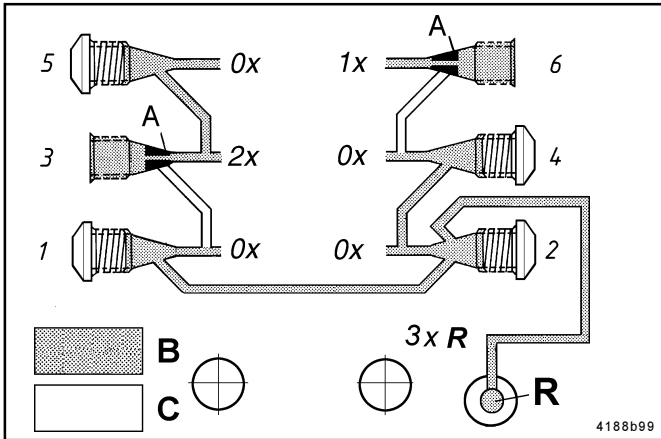

Fig. 4 - Internal return of supplied lubricant on back-mounted SSV divider blocks

x - outlet quantity (single, double, etc)

1...6 outlet numbers

A - clamping ring (brass)

B - lubricant supply

C - lubricant enclosed

R - return line borehole

**Lube points**

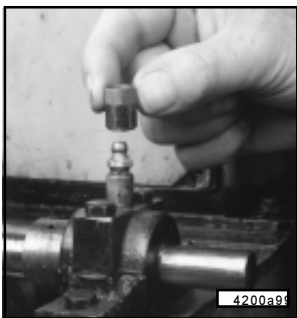

Fig. 5 - Place the Zerk-Lock body over the grease fitting



Fig. 6 - Installation of Zerk-Lock body with staking tool

**Installing Quicklinc fittings into lube points (for metric size accessory kits only)**

- \* Remove lube fittings from lube points and install appropriate Quicklinc fittings into the bore holes of the lube points.

**Installing Zerk-Locks onto grease fittings (for inch size accessory kits only)**

- The Zerk-Lock fitting consists of the Zerk-Lock body, insert and a Quicklinc fitting.
- \* Place the Zerk-Lock body onto the grease fitting.
- \* Use a staking tool (part of the accessory kit) and a hammer to push in the Zerk-Lock insert until the grease fitting is tightly enclosed by the insert.

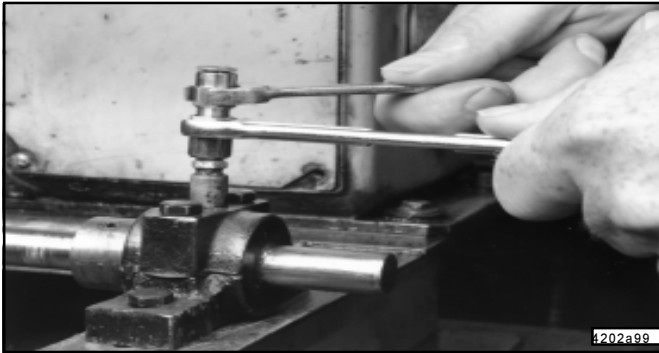

Fig. 7 - Screwing Quicklinc fitting into the Zerk-Lock body

- \* Screw the Quicklinc fitting into the Zerk-Lock body and tighten until parts resist further tightening, (about 1 1/2 turns).

*Note: Quicklinc hex. is 12 mm. Zerk-Lock body hex. is 1/2".*

- \* Move the Zerk-Lock and tube fitting from side to side on the grease fitting to insure the Zerk-Lock is firmly seated on the fitting.

### Connection of Feed Lines



Fig. 8 - Connect feed line to the Quicklinc fitting

- \* Measure, cut and route the feed lines included in the kit.

*Note: Avoid sharp bends of the plastic tubing and the moving parts of the machine that could damage the lubrication lines. Minimum bending radius is 50 mm (2in).*

- \* Secure the lubrication lines using nylon ties or corrugated tube provided in the accessory kit.
- \* If the lines are not primed, prime all lubrication feed lines before connecting them to the lube point (by means of a filling pump, a manual pump or by triggering additional lubrications).
- \* Connect feed lines to the check valves of the divider block and to the Quicklinc fittings of the lube point.

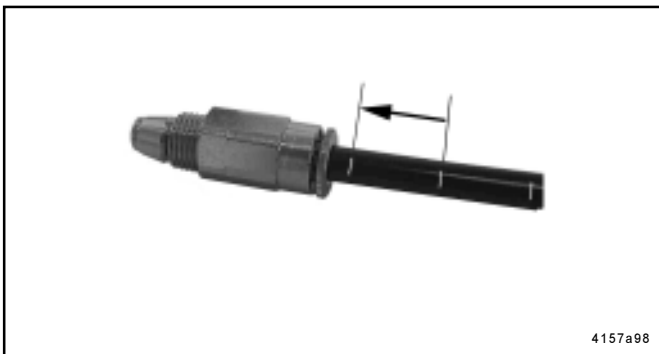

Fig. 9 - Feed line insert into the Quicklinc fitting up to the next white mark

*Note: Push the end of the line firmly into the Quicklinc fitting until it is fully seated in the body. The primed feed lines are marked with white lines (fig. 8, 9) as an installation aid.*

- \* Cut the feed line off at one of the white lines before it is mounted.
- \* Then insert the feed line into the fitting up to the next white mark.
- This will ensure a correct installation of the feed line in the tube fitting.



Fig. 10 - Vent hole on reservoir

### Filling of reservoir

- \* Fill the reservoir with clean suitable lubricant.

**Caution:** When filling the reservoir avoid air pockets in the lubricant. Make sure that the follower plate seal moves above the vent hole to ensure that all air pockets are vented (see fig.11).

**Caution:** When filling the reservoir make sure that the **maximum marking will not be exceeded. If the reservoir is overfilled, it might burst!**

### QLS 321 Selection Guide

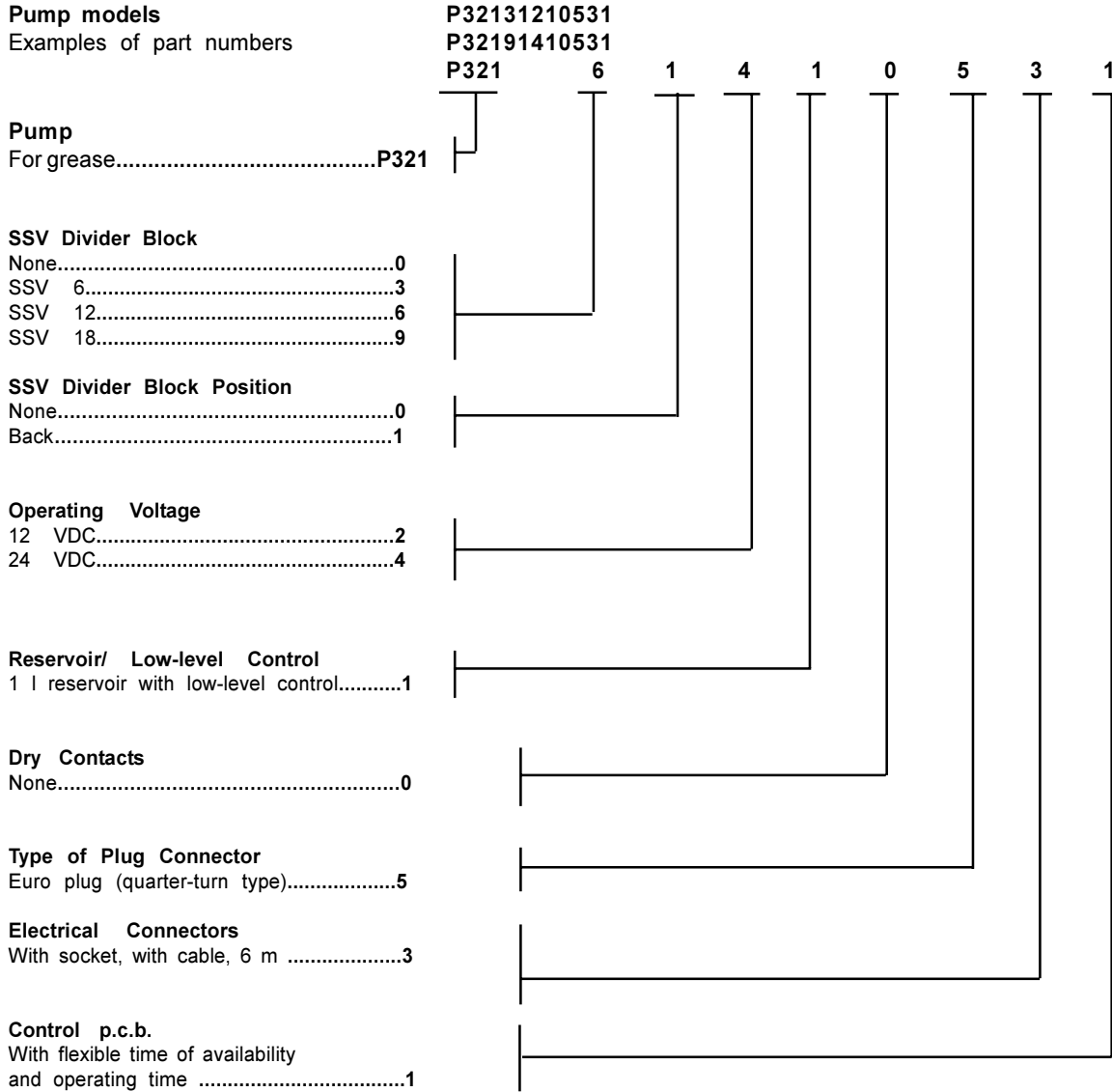

**Example of an explained model number**

**Pump model P32131410531**- Grease pump, SSV 6 block mounted on the back, 24 VDC, with low-level control and without dry contact, with scart plug, socket and 6m cable, control p.c.b.

\* Note: 1. Pumps are equipped with euro plug and connection cable of 6m length (only connection type 3)

**Accessory Kits:**

**Inch Size Kits:**

- SSV 6/8 part n°. 550-36971-1
- SSV 12 part n°. 550-36971-2
- SSV 18 part n°. 550-36971-3

**Metric Size Kits:**

- SSV 6/8 part n°. 550-36970-1\*\*\*
- SSV 12 part n°. 550-36970-2\*\*\*
- SSV 18 part n°. 550-36970-3\*\*\*

\*\*\*Lube fittings must be ordered separately.

Subject to modifications

## Electrical Connecting Diagram

### Electrical Connection

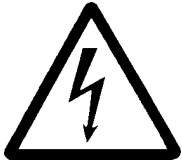

**Warning:** Before putting into operation make sure that the **electrical supply is off**. The device may not be connected or disconnected when the power is on.

\* Connect the electrical wires according to the following electrical connecting diagram.  
*Note: The protection IP6K9K is guaranteed when the socket is tightened.*

### Direct Current (VDC)

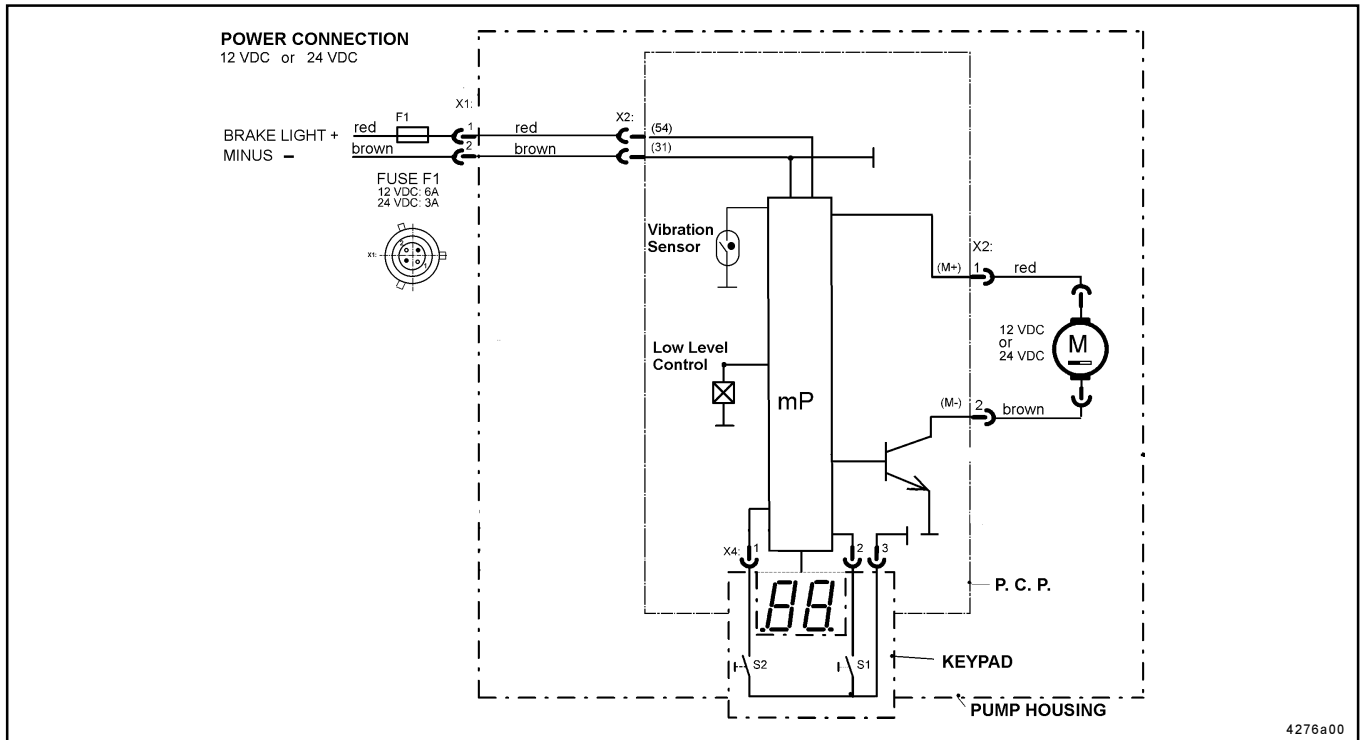

Fig. 11 - Electrical Connecting Diagram, direct current

## Description of QLS 321

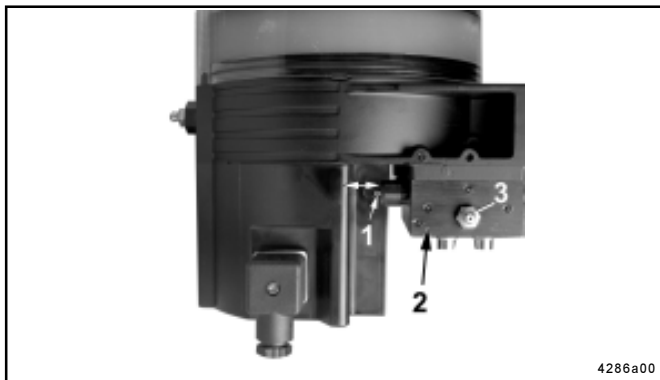

Fig. 12 - QLS 321 with back position of the SSV divider block

- 1 - Control pin  
2 - SSV divider block  
3 - Nipple for external manual lubrication

- The QLS321 is a compact centralized lubrication system for providing a **maximum of 18 lube points** on trailers and semitrailers with lubricant.
  - The QLS 321 is available in the following basic configurations:
    - SSV divider block mounted on the back (see fig. 12)
    - Pump without the SSV divider block attached (no fig.).
  - The standard lubrication line to be used is high pressure plastic tubing ( $\varnothing$  6x1.5 mm; 1/4 in.) included in the accessory kit.
- Note: The operation of the QLS 321 is independent of the mounting position of the SSV divider block.*
- When braking, a signal from the control p.c.b. starts the electrical motor and the pumping element starts pumping the lubricant to the SSV divider blocks and to the lube points.
  - As soon as the flexible time of availability has finished and all lube points have received lubricant, one lubrication cycle is completed.

## Operation of the QLS 321

### Pump

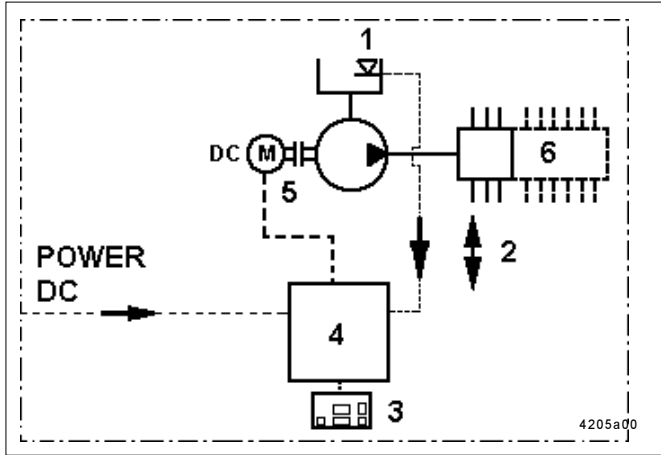

Fig. 13 - QLS 321 unit

- The QLS 321 operates according to lube cycles (flexible time of availability and operating time).
- The first braking starts the flexible time of availability as well as the operating time.
- A division of the lube points (option) via secondary metering devices (SSV 6) and one main divider block (SSV 6) is **possible only up to a maximum of 18 lube points per lube cycle**.

- |                       |                      |
|-----------------------|----------------------|
| 1 - Low-level control | 2 - Control pin      |
| 3 - Keypad            | 4 - Control unit     |
| 5 - Pump              | 6 - SSV 6, 8, 12, 18 |

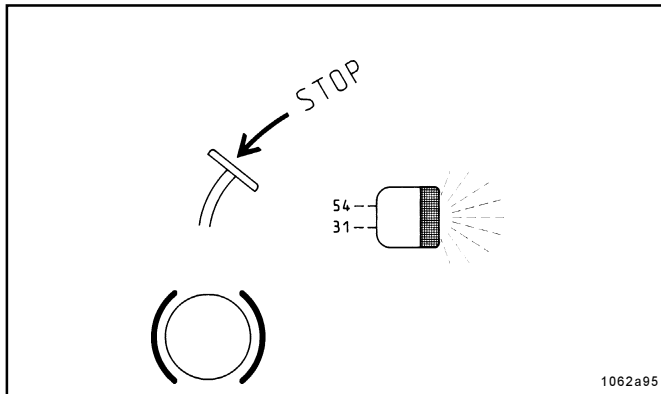

Fig. 14 - Stoplight voltage

- Most of the time, trailers and semitrailers do not have a permanent power supply. The stoplight voltage provides the power supply (terminal 54). Further, trailers and semitrailers lack the operation dependent signal of terminal 15 (ignition voltage) which exists for trucks.

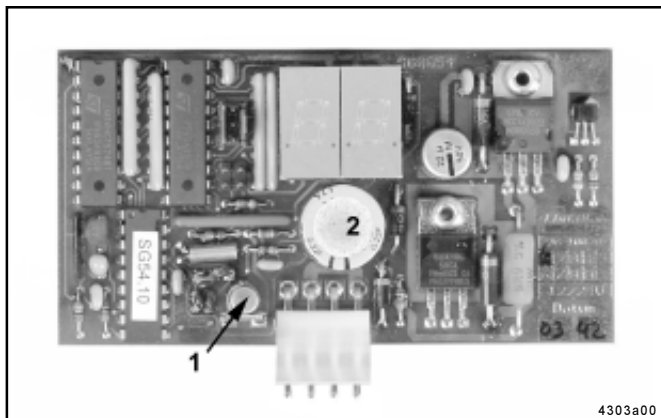

Fig. 15 - Control p.c.b. 236-10028-1

- |                   |
|-------------------|
| 1 - Motion sensor |
| 2 - Condenser     |

- In the control p.c.b., this task is provided by an integrated motion sensor 1 (fig. 15). It records travelling motions of the trailer/ semitrailer. Out of this recorded material, it forms the necessary operation dependent signal for controlling the time of availability.
- Normally, the stoplight voltage lasts for a short instance only. Therefore, a condenser is needed to record the times (see fig. 15). During the braking process, the condenser loads and is then available as a continuous power supply in order to provide the operation dependent signal.



**Time of Availability - Operating Time**  
Time Sequence Diagram

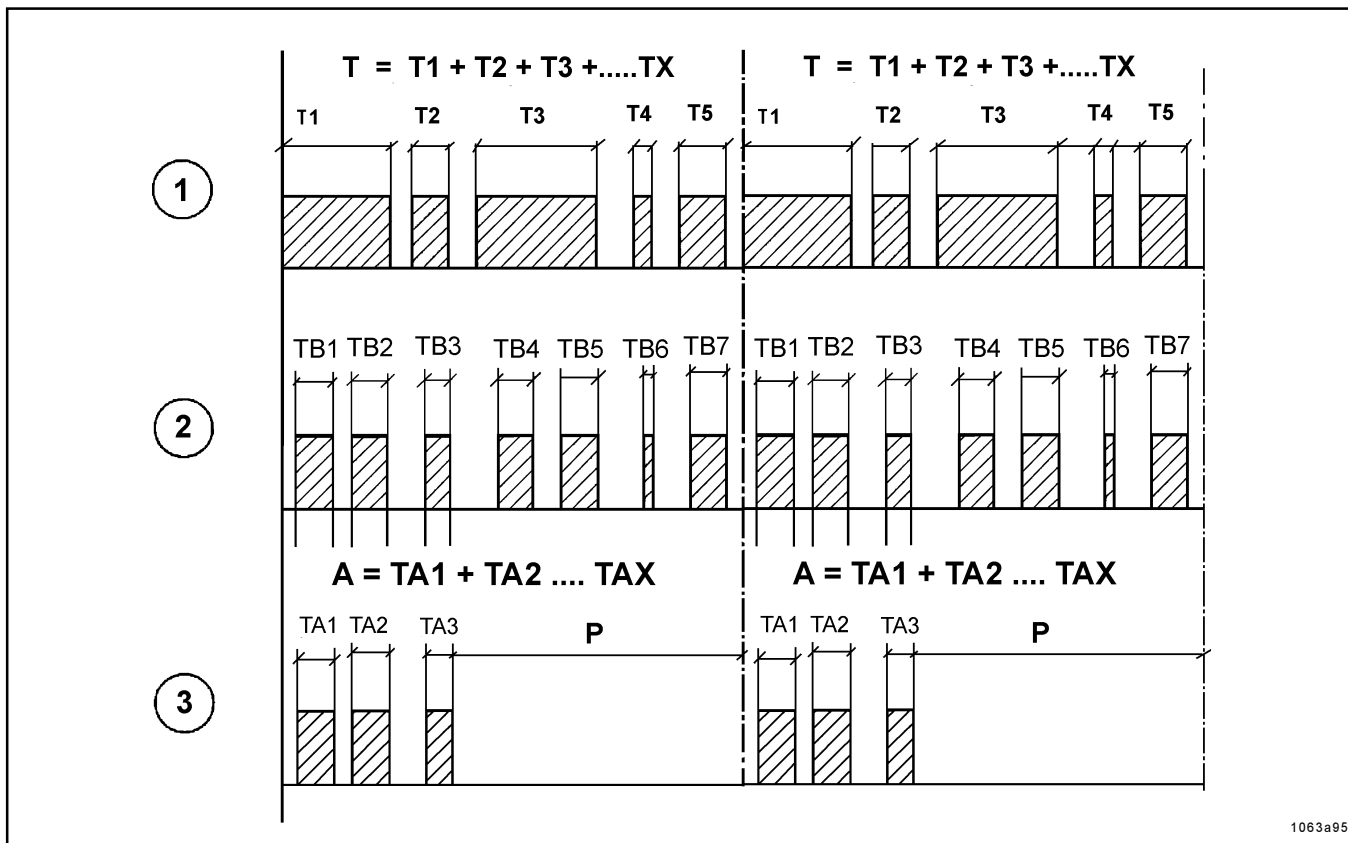

1063a95

Fig. 16 -Time sequence diagram

- 1 - Time of availability (2 cycles shown)
- 2 - Braking time sequence
- 3 - Operating time sequence
- T - Time of availability, flexibly adjustable

- T1...TX - Individual travelling times
- TB1...TBX - Individual braking times
- A - Preset operating time
- TA1...TAX - Individual operating times
- P - Pause time

**Time of Availability**

- The time during which the printed circuit board records the travelling motions by means of the motion sensor 1 (fig. 15) is defined as the time of availability.
- The time of availability T (fig. 16) starts with the operating time (A), i.e. the QLS 321 is prepared to turn individual braking operations (TB1...TBX) into lubrication cycles (TA1...TAX, operating times) until the preset operating time (A) elapses.
- As soon as the vehicle starts travelling, the motion sensor starts the time of availability (T1 ..TX).
- Each time the vehicle stops, the time of availability also stops. The electronic unit records the times which have elapsed so far (T1...TX).
- When the vehicle moves again, the time of availability continues to run from the point where it had been interrupted when the vehicle stopped.

- The travelling times are stored until the preset time of availability is reached.
- The layout of the control unit is such that during the preset time of availability (T, pure travelling time) one operating time (A) elapses.
- Once the time of availability (T) has elapsed, a new cycle begins.
- The time of availability (T) can be modified and is adjustable on the key pad from 1, 2, 3...up to 16 hours (increment 1 hour).

Subject to modifications

**Operating Time**

- The operating time stands for the run time of the QLS 321 whereby the motor of the QLS 321 is switched on.
- The operating time elapses during the time of availability. When braking, the voltage of the stop light (terminal 54) provides the motor of the QLS 321 with power. The motor then runs during the braking process.
- The operating time (TA1, fig. 16) starts with the first braking actuation (TB1 = TA1, etc.).
- The electronic unit records the duration of each braking operation (operating time) which is added to the preceding one until the preset operating time (A) is reached.
- After each further braking (example: TB 4) there is no more operation time until the time of availability (T) is completed and starts again.
- The operating time (T) may be preset from 1, 2, 3... up to 32 minutes (increment 1 minute) on the key pad.
- The operating time
  - depends on the lubricant requirement;
  - is adjustable.
- The longer the operating time, the greater the lubricant requirement and vice-versa.

**Pressure Relief Valve**

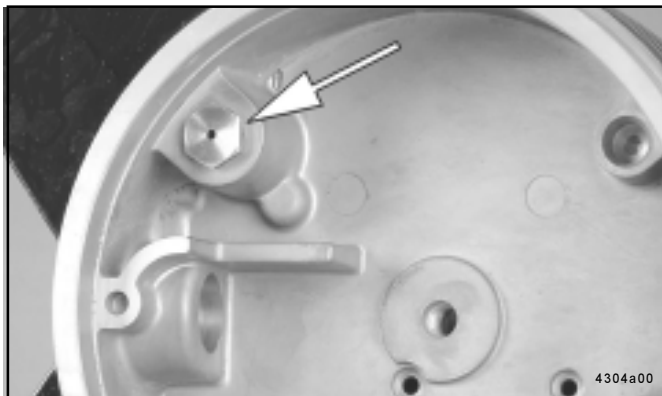

Fig. 17-Pressure relief valve (cartridge) in housing

- The QLS 321 is protected with a pressure relief valve.
- The pressure relief valve limits the pressure build-up in the QLS 321 and opens at an overpressure of 205 bar.
- If the pressure relief valve is actuated, this indicates that the system is malfunctioning. The lubricant flows back into the reservoir (hardly visible).
- If this is the case, trigger an additional lubrication and observe the control pin on the divider block (fig. 12). If the control pin does not move, either the system is blocked or the reservoir is empty, see fault indication "LL" on the display.

*Note: To trigger an additional lubrication, connect the trailer to the truck, connect the driving switch and actuate the brake so that the stop light of the trailer will flash.*

**Display Window on the Key Pad**

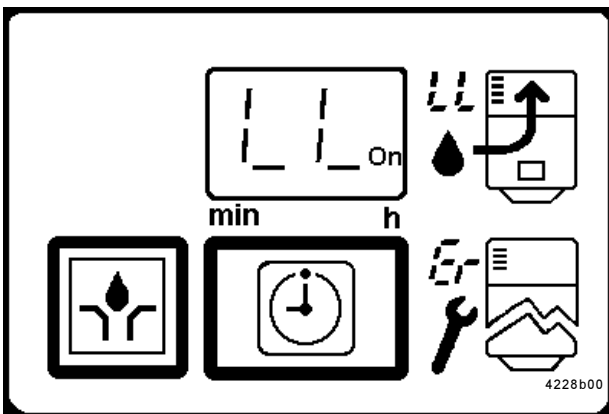

Fig. 18 - Key pad with display of a fault indication

- All settings (programmings) are effected via the key pad (2 key buttons) on the front side of the QLS 321, also see under 'Setting and Operation of the QLS 321'.
- The operating conditions are indicated via an LED display of seven segments (alphanumeric). The display is visible through a window in the key pad.
- The reservoir of the 321 is equipped with a low-level control, which indicates an "LL" on the display.
- During each actuation of the brake where no operating time takes place the display is tested, i.e. all segments and decimal points flash for 2 seconds, see 'Display mode'.

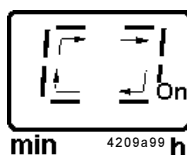

Fig. 19 - Green rotating display, operating time

- Pump operation is indicated on the display window of the key pad by a rotating green light movement.

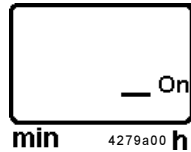

Fig. 20 - Green segment, time of availability

**Initiate additional lube cycle**

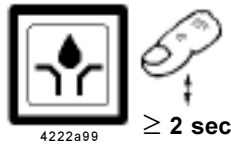

Fig. 21 - Pushbutton for additional lubrication cycle

**Low-level control**

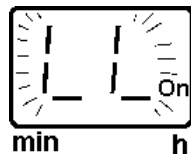

Fig. 22 - Display of a low-level indication, flashing display

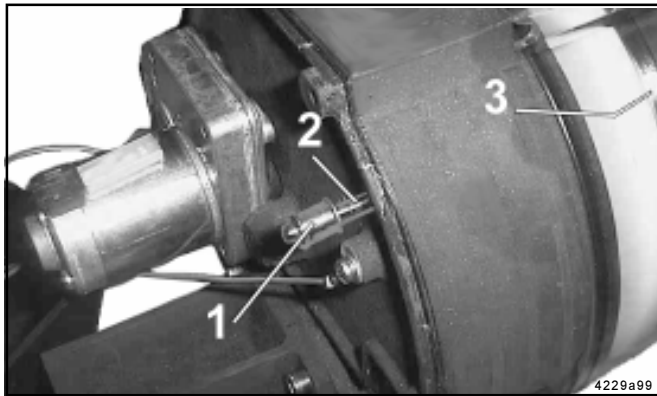

Fig. 23 -Components of the low-level control

- 1 - Magnet
- 2 - Pin
- 3 - Follower plate

- During each braking process where no operation time elapses, the display will be tested and all segments and decimal points flash for 2 seconds. Then, the segment on the bottom of the right side of the display window (On) flashes during one braking process (flexible time of availability).

- Can be initiated at any time, provided that the power supply (stop light) is applied, i.e. the trailer is connected to the truck, the driving switch is switched on and the brake is actuated.
- \* Additional lubrication:
  - is initiated via the button (fig. 21). Press the button for more than 2 seconds. Then, the rotating segment (fig. 19) becomes visible on the key pad.
  - can be initiated at any time.

- If the reservoir is empty, a flashing fault indication \* LL \* will appear on the display of the key pad. However, therefore, the power supply (stoplight) must be applied on the QLS 321.
- The follower plate 3 (fig. 23) of the reservoir moves the pin 2 with the magnet 1 ahead of the control p.c.b. and, thus, initiates the low-level signal.
- In case of a low-level indication, the pump completes the current lube cycle (operating time). Then, no other lubrication process will be initiated.
- Only after refilling the lubricant reservoir the pump is automatically prepared for operation again and the flashing low-level signal \* LL \* will be cancelled.

## Malfunction

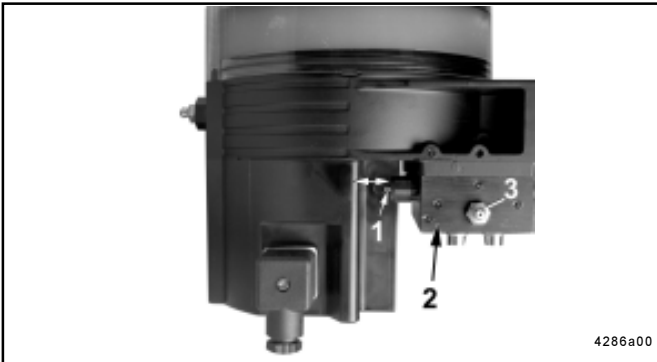

Fig. 24 - QLS 321 without proximity switch, movement of the control pin

- 1 - Control pin
- 2 - SSV divider block
- 3 - Nipple for additional lubrication

- Possible visible malfunctions:  
Either the pump is defective, power supply is interrupted, the secondary system is blocked or there is a low-level indication in the reservoir.
- The display of the key pad shows whether the pump is defective or the power supply is interrupted.
- A malfunction of the secondary system is visible on the control pin 1 (fig. 24). If during the operating time the control pin does not move to the left and right, this indicates a malfunction. In this case, the pump of the QLS 321 does not return the grease visibly via the pressure relief valve (fig. 20) back to the reservoir.  
*Note: The point of time of the movement of the control pin depends on the size of the attached divider block. It may take some time (max. 3 min) until the pump has supplied the lubricant quantity needed for the control pin to move.*

- For examination purposes, initiate an additional lubrication and observe the movement of the control pin.
- In case of a low-level indication, \* LL \* will flash on the display of the key pad, see 'Low-level control'.

## Setting and operation of the QLS 321

- Three possible modes of operation and settings can be selected on the key pad:
  - Display mode
  - Operating mode
  - Programming mode

### Display mode

<p>4288a00</p>	<ul style="list-style-type: none"> <li>• As soon as voltage is applied to the pump of the QLS 321, the key pad is automatically in <b>display mode</b>. The <b>right-hand segment</b> is illuminated in the display.</li> <li>• Normally, the display is dark. Only the functions (segment, rotating segment display) or low-level signals (* LL *) flash on the display.</li> <li>• <b>Display mode</b> <ul style="list-style-type: none"> <li>- The user receives information on functions and malfunctions of the QLS 321.</li> </ul> </li> </ul>
<p>4207a99      4227a99</p>	<ul style="list-style-type: none"> <li>- A test display is made when the voltage (stop light) is applied, all segments and decimal points flash for 2 seconds.</li> <li><i>Note: If * EP * is displayed after the display test, this indicates that a button or the key pad is defective.</i></li> </ul>
<p>4279a00</p>	<ul style="list-style-type: none"> <li>- The right-hand segment (On) indicates the available voltage supply during the flexible time of availability. As soon as another message is displayed, the segment turns off.</li> </ul>
<p>4209a99</p>	<ul style="list-style-type: none"> <li>- The operating time is displayed as a rotating segment.</li> </ul>
<p>4211a99</p>	<ul style="list-style-type: none"> <li>- * LL * is shown to indicate low-level. After refilling the reservoir, the signal turns off again.</li> </ul>

Fig. 25 - Key pad in display mode

Operating mode



Display	Press	
 min 4279a00 h  min 4209a99 h	 ≥ 2 sec	<p><b>Important:</b> The operating mode is accessible only during the time of availability. It cannot be operated during the pump operating time.</p> <ul style="list-style-type: none"> <li>• Precondition: Trailer connected, driving switch switched on, brake actuated, power supply (stop light) applied. Segment (On/h) on the right bottom side flashes.</li> </ul> <p><b>Operating option: Initiating an additional lube cycle</b></p> <ul style="list-style-type: none"> <li>* Press the button to reset the elapsed time of availability. The operating time starts. A rotating segment is visible on the display during the whole operating time.</li> </ul>
 min 4208a99 h  min 4282a00 h after 2 sec.  min 4301a00 h after 2 sec.  min 4299a00 h after 2 sec.  min 4216a99 h after 2 sec.  min 4283a00 h after 2 sec.  min 4284a00 h after 2 sec.  min 4285a00 h	 ≥ 2 sec	<p><b>Operating option: Information on preset time of availability and remaining time of availability</b></p> <p><b>Example:</b>  <i>Pi = 04 min Pb = 12 h rb = 10 h 09 min</i></p> <p>Press button.</p> <p><i>Note: The following display sequences are shown twice and are cancelled after 60 seconds. The change of display occurs every two seconds. Example:</i></p> <p>Pi (preset operating time)                      .04 (minutes)</p> <p>Pb (preset time of availability)                      12 . (hours)</p> <p>rb (remaining time of availability)                      10 . (hours)</p> <p>. 09 (minutes)</p>

Fig. 26 - Display in operating mode

Subject to modifications

Operating mode, continuation

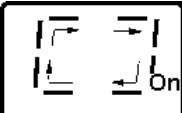
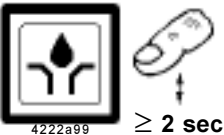
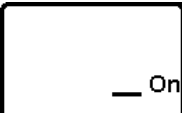
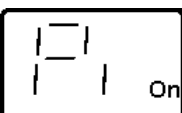
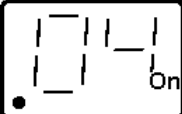
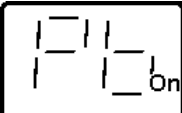
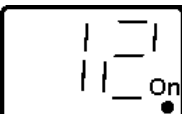
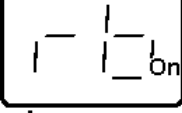
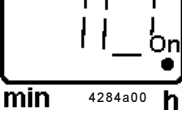
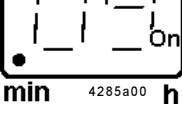
Display	Press	
<p>min 4277a00 h</p>	after 2 sec.	<p><b>AC</b> - Counting of automatically initiated lube cycles. Up to 9999 cycles countable. Then, counting starts from the beginning again.</p> <p>Example: 0625 cycles</p> <p>Display for hundreds and thousands <b>06</b> - as 600</p> <p>Display for tens and units. <b>25</b></p> <p><b>UC</b> - Counting of manually (User) initiated additional lube cycles. Up to 9999 cycles countable. Then, counting starts from the beginning again.</p> <p>Example: 0110 cycles</p> <p>Display for thousands and hundreds. <b>01</b> - as 100</p> <p>Display for tens and units. <b>10</b></p> <p>Appears after the second sequence.</p>
<p>min 4281a00 h</p>	after 2 sec.	
<p>min 4280a00 h</p>	after 2 sec.	
<p>min 4278a00 h</p>	after 2 sec.	
<p>min 4297a00 h</p>	after 2 sec.	
<p>min 4226a99 h</p>	after 2 sec.	
<p>min h</p>	after 60 sec.	

Fig. 27 - Display in operating mode

**Programming mode**

<p>Display Press Press</p>	<p>* To access to the programming mode, press both buttons at the same time &gt; 4 seconds.</p> <p><b>Programming options - Pause time:</b></p> <p>P1(time of availability) 0 - 16 hours P2 (operating time) 0 - 32 minutes</p>
	<p><b>Setting of time of availability P1</b></p> <p>* Settings are made in one direction only: 1, 2, 3,....16 h Button pressed once .....increases by 1 hour Button pressed continuously.....quick sequence</p> <ul style="list-style-type: none"> <li>The field "hour" is indicated by a <b>decimal point on the right-hand side for the hours.</b></li> </ul>
	<p><b>Setting of operating time P2</b></p> <p>* Settings are made in one direction only: 1, 2, 3,....32 min Button pressed once .....increases by 1 minute Button pressed continuously.....quick sequence</p> <ul style="list-style-type: none"> <li>The field "minute" is indicated by a <b>decimal point on the left-hand side for the minutes.</b></li> </ul>
	<p><b>Completing the programming:</b></p> <p>* Press button. "P -" is displayed.</p> <ul style="list-style-type: none"> <li>The <b>completion of the programming</b> is effected by pressing the button shown on the left side (additional lube cycle).</li> </ul> <p><i>Note: If the button for the additional lube cycle is not pressed within 30 seconds, the previous programming remains valid.</i></p> <p><b>Important:</b> After completing the programming, examine the settings of the time of availability and of the operating time in the display mode (see page 14) again.</p>

Fig. 28 - Display in the programming mode





## Troubleshooting

Pump of the QLS 321 system

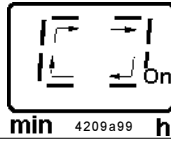

- The rotating light segment on the display of the key pad indicates that the pump operates properly.

<ul style="list-style-type: none"> <li>• <b>Fault: Pump motor doesn't run</b></li> </ul>	
<ul style="list-style-type: none"> <li>• <b>Cause:</b></li> <li>• Power supply interrupted. Green decimal point On/h on display is not lit.</li> <li>• Power supply from printed circuit board to motor interrupted. Electric motor defective.</li> <li>• Printed circuit board defective.</li> <li>• Key pad or button defective.</li> </ul>	<ul style="list-style-type: none"> <li>• <b>Remedy:</b></li> <li>* Check the voltage supply from the stop light to the pump. If necessary, eliminate the fault or replace the fuses.</li> <li>* Check the feed line to the fuses to the plug of the pump and then to the printed circuit board.</li> <li>* Initiate an additional lube cycle. Check voltage supply from the printed circuit board to the motor. If necessary, replace motor.</li> <li>* Replace printed circuit board.</li> <li>* * EP * display will flash. Replace housing with key pad.</li> </ul>
<ul style="list-style-type: none"> <li>• <b>Fault: Pump does not deliver lubricant</b></li> </ul>	
<ul style="list-style-type: none"> <li>• <b>Cause:</b></li> <li>• Reservoir empty. "LL" display at the key pad is flashing.</li> <li>• Pump does not dispense lubricant and the control pin on the SSV divider block does not move.</li> <li>• Air pockets in lubricant.</li> <li>• Improper lubricant has been used.</li> <li>• Suction hole of pump element clogged.</li> <li>• Pump piston is worn.</li> <li>• Check valve in pump element defective or clogged.</li> <li>• Other damages.</li> </ul>	<ul style="list-style-type: none"> <li>• <b>Remedy:</b></li> <li>* Fill up the reservoir with clean grease. Let the pump run (initiate an additional lube cycle) until the lubricant shows at all lube points. <i>Note: Depending on the ambient temperature and/or sort of lubricant the pump element needs a longer run time to reach the full output capacity. Therefore, initiate several additional lube cycles.</i></li> <li>* Trigger several additional lube cycles. Lubricant must dispense without air bubbles.</li> <li>* Change the lubricant. Request for lubricant table.</li> <li>* Remove pump element. Check suction hole for foreign particles. If there are any, remove them.</li> <li>* Replace pump element.</li> <li>* Replace or clean pump element.</li> <li>• Return pump to factory for maintenance.</li> </ul>

## Troubleshooting, continued

### Divider Block of the QLS 321

<p>• <b>Fault: Blockage in the downstream progressive system</b></p>	
<p>• <b>Cause:</b></p> <ul style="list-style-type: none"> <li>• Bearings, lines or divider block clogged</li> <li>• Mounting position of divider block: back-side            – In the case of the divider blocks SSV 6, SSV 12 or SSV 18 the outlet 1 is closed and 2 is connected.            The fault can be identified as follows:            The indicator pin mounted on the divider block piston does not move.</li> </ul>	<p>• <b>Remedy:</b></p> <ul style="list-style-type: none"> <li>• Determine the cause of the blockage as described in the following example and eliminate it.</li> <li>* Let the pump run (refer to “Initiating an additional lube cycle”)</li> <li>* Disconnect all feed lines D (fig. 31) of the divider block one after the other. If grease or oil shows under pressure, i.e. at outlet 3 of the divider block, the blockage is located in the line of outlet 3 or in the connected bearing point.</li> <li>* Pump through the blocked line or bearing point using a hand pump.</li> </ul> <p><i>Note: To check the individual outlets, leave all outlets disconnected for a while, since only one piston stroke is executed with each motor revolution. Several strokes are required for a full cycle of all divider blocks.</i></p> <ul style="list-style-type: none"> <li>* Check pressure relief valve (fig. 17). Replace it, if necessary.</li> </ul>
<p>Fig. 31 - Example of a QLS 321</p>	
<p>A - Pressure relief valve      C - SSV 12 divider block          B - Pump                              D - Feed lines</p>	

Troubleshooting, continued

<p>• <b>Fault: Blockage in the downstream progressive system, continued</b></p>	
<p>• <b>Cause:</b></p> <ul style="list-style-type: none"> <li>• Divider valve is blocked.</li> </ul>	<p>• <b>Remedy:</b></p> <ul style="list-style-type: none"> <li>* Replace the divider block or clean it as follows:</li> <li>* Remove all threaded tube fittings.</li> <li>* Unscrew piston closure plugs.</li> <li>* Remove the piston, if possible, with a soft mandrel (smaller than <math>\varnothing</math> 6 mm, 0.24 in.).</li> </ul> <p><b>Important:</b> The pistons are individually fitted in the bore holes of the divider block. After removing the pistons, mark them in order to reinstall them in the right direction and position. They may not be interchanged.</p> <ul style="list-style-type: none"> <li>* Thoroughly clean the divider block body in a grease-dissolving detergent and dry it out with compressed air.</li> <li>* Clean through the material passages (<math>\varnothing</math> 1.5 mm, 0.59 in.) at the thread ends of the piston bore holes by using a pin.</li> <li>* Clean the divider block once more and dry it thoroughly.</li> <li>* Reassemble the divider block.</li> </ul>
<p>• <b>Fault: Differing lubricant amounts at the lube points.</b></p>	
<p>• <b>Cause:</b></p> <ul style="list-style-type: none"> <li>• Lubricant metering not correct.</li> <li>• Setting of the time of availability incorrect.</li> </ul>	<p>• <b>Remedy:</b></p> <ul style="list-style-type: none"> <li>• Check the lubricant metering acc. to the lubrication chart.</li> <li>• Check, adopt and optimize time setting according to the requirements.</li> </ul>

## Technical Data

### QLS 321, general

Operating temperature ..... -25° C to 70° C (-10° F to 160°F)  
Maximum operating pressure  
(Pump without divider block) .... approx. 205 bar (3,000psig)  
Number of outlets ..... 6, 12, 18  
Output per outlet and cycle ..... approx. 0.2 cm<sup>2</sup>  
Reservoir capacity ..... 1.0 l  
Lubricant ..... up to NLGI 2 Grease  
Weight (average) ..... 5.7 kg (12.5 lbs)  
Protection ..... IP6K 9K acc. to DIN 40050 T9 (NEMA 4)  
Reverse polarity protection:  
The operating voltage inlets are protected against reverse polarity.

### Electrical Data DC (Direct Current)

Operating voltage ..... 12 V, - 20%/+ 30 %  
Max. operating current ..... 2.0 A  
Operating voltage ..... 24 V, - 20%/+ 30 %  
Max. operating current ..... 1.0 A  
Residual ripple in relation  
to the operating voltage ..... ± 5% acc.to DIN 41755

*Note: The pump motors are suitable for intermittent operation only.*

- Regulations and standards:
  - the vehicle guideline 95/245/EC
  - EMV regulation for on-road vehicles acc. EN 40839 parts 1, 3 and 4

### Time setting

Factory setting  
Flexible time of availability ..... 6 hours/cycle  
Range of flexible time of availability ..... 1 to 16 hours,  
..... , increment 1 hour  
Factory setting  
Operating time ..... 6 minutes/cycle  
Operating time range ..... 1 to 32 minutes,  
..... , increment 1minute  
Timer memory ..... indefinite over EEPROM

### Lubrication lines

Pressure plastic tube (ø 6x1.5 mm;1/4 in.)  
Min. bending radius ..... 50 mm  
Bursting pressure at 20 ° C ..... approx. 210 bar (3050 psi)

### Tightening Torques

#### Pump

Electric motor to housing ..... 3 Nm (2.5 lb-ft)  
Pump element in housing ..... 25 Nm (19.0 lb-ft)

#### Divider Block

Closure plug (piston) in divider block ..... 18 Nm (13.5 lb-ft)  
Closure plug (outlets) in divider block ..... 15 Nm (11.0 lb-ft)  
Outlet fitting in divider block  
screw-type ..... 17 Nm (12.5 lb-ft)  
push-in type ..... 12 Nm (9.0 lb-ft)  
Compression nut onto outlet fitting, screw-type  
plastic tube ..... 10 Nm (7.5 lb-ft)  
steel tube ..... 11Nm (8.0 lb-ft)  
Fitting for control pin ..... 18 Nm (13.5 lb-ft)  
Mounting of the divider block (M 6, 8.8) ..... 10 Nm (8.0 lb-ft)

## Dimensions

### Pump

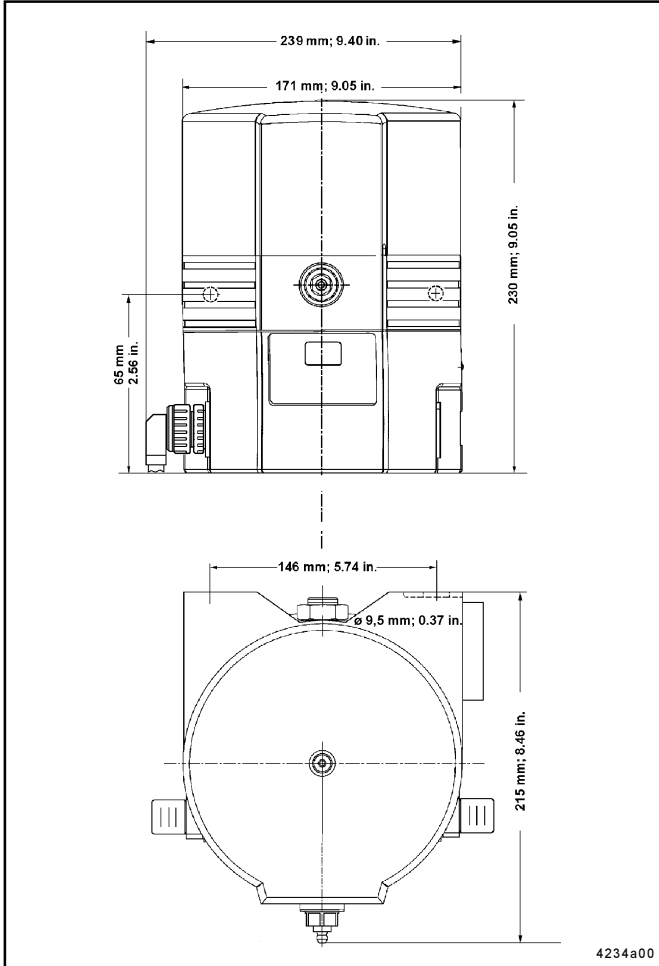

Fig. 32- Dimensions of the QLS 321

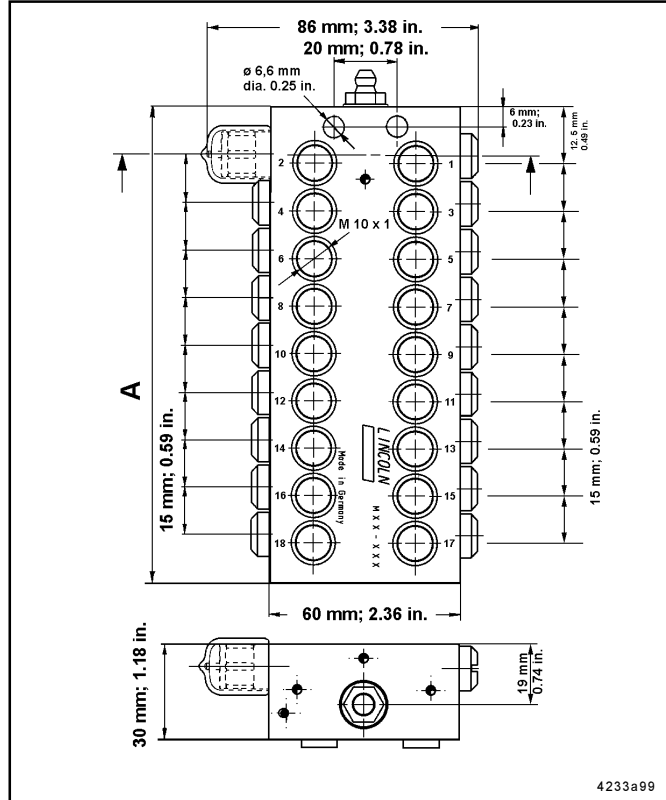

Fig. 33 - Dimensions of the back mounted SSV divider block

Number of Outlets	Dimensions A in mm (in.)
6	60 (2.36)
12	105 (4.13)
18	150 (5.90)

**Optional for metric fittings (not provided in the accessory kits)**

Tube fittings, screw-type or push-in type for SSV outlets

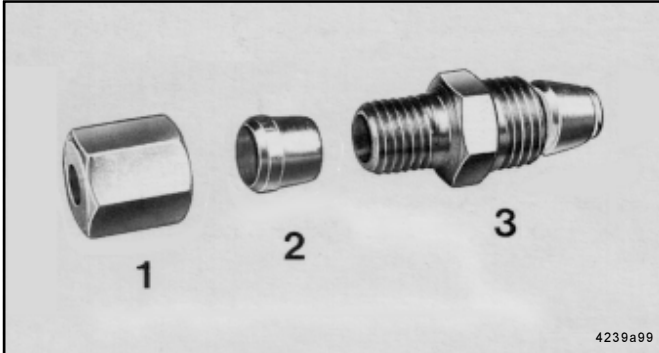

Fig. 34 - Check valve, screw-type

- 1 - Coupling nut
- 2 - Cutting ring
- 3 - Valve body with cutting and clamping ring

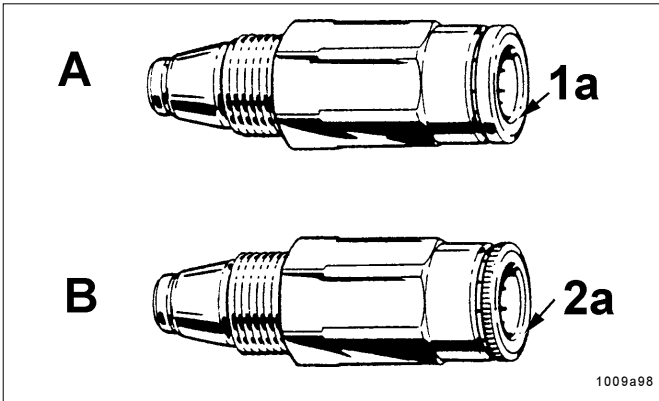

Fig. 35 - Different types of check valves

**Connecting the high-pressure plastic hose or the pressure plastic tube.**

- For high-pressure plastic hose ( $\varnothing$  8.6x2.3 mm) use check valves type A (fig. 35) with reinforced collar 1a and smooth flange (part nr. 226-14091-4)
- For pressure plastic tube ( $\varnothing$  6x1.5 mm) use check valve type B (fig. 35) with standard collar (part nr. 226-14091-2)

- A - Check valve with reinforced collar
- B - Check valve with standard collar
- 1a - smooth flange
- 2a - knurled flange



Fig. 36 - Check valve with reinforced collar and high-pressure plastic hose

*Note: On construction machines or agricultural machines use high pressure plastic hoses as feed lines. In such cases the check valves of the divider blocks must have a reinforced collar and a smooth flange (1a).*

**Important:** Connect only high-pressure plastic hoses ( $\varnothing$  8.6x2.3 mm) with threaded sleeve and hose studs to the check valves with reinforced collar.

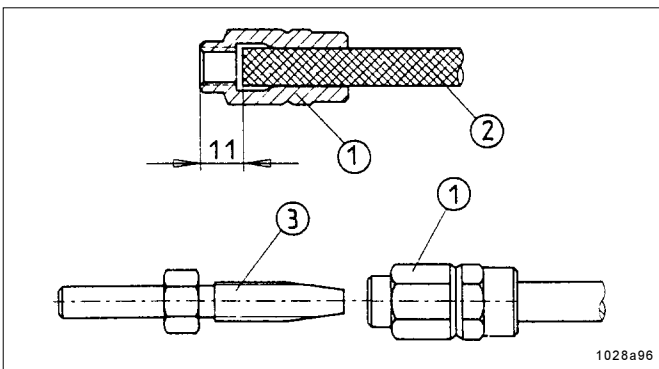

Fig. 37 - Preassembly of the threaded sleeves and hose studs on the high-pressure plastic hose.

**Fitting the threaded sleeves and hose studs on the high-pressure plastic hose**

- \* Screw the threaded sleeve 1 (fig. 38) counterclockwise onto the high-pressure plastic hose 2 until the illustrated dimension of 11mm is reached.
- Important:** Oil parts 1 and 3 properly before screwing them together.
- \* Then screw the hose stud 3 into the threaded sleeve 1.

- 1 - Threaded sleeve
- 2 - Main line
- 3 - Hose stud

Subject to modifications

### Service Parts and Kits for the QLS 321

QLS 321 with back mounted SSV divider block

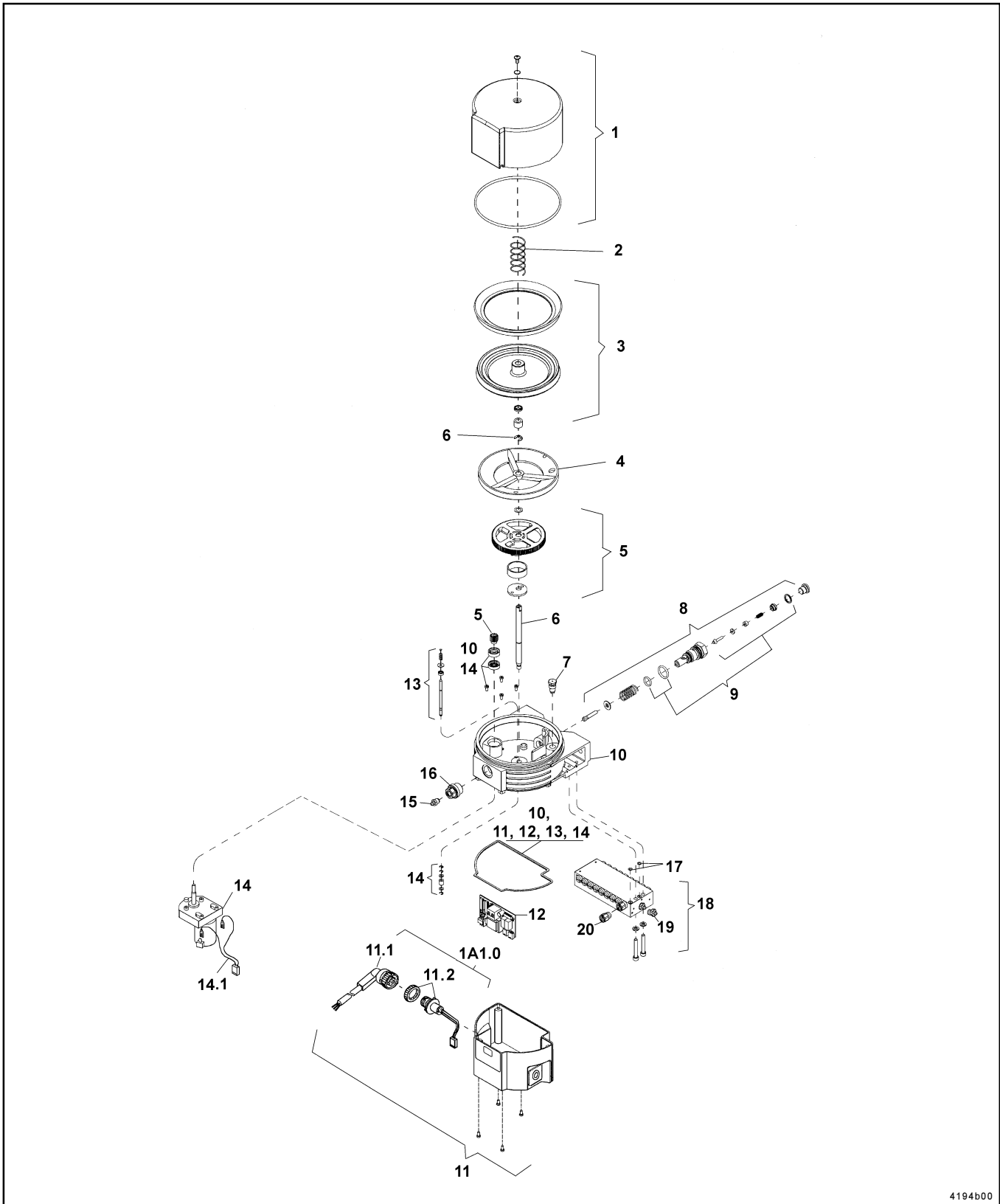

4194b00

Fig. 38 - QLS 321with back mounted SSV divider block

Subject to modifications



**Parts List**

Pos.	Designation	Kit	Part	Qty	Part No..
1	Reservoir	x		1	550-36979-2
2	Spring for follower piston		x	1	218-14172-6
3	Follower piston	x		1	550-36979-3
4	Intermediate plate	x		1	450-24749-1
5	Eccentric gear	x		1	550-36979-4
6	Shaft	x		1	550-36979-1
7	Valve insert		x	1	235-14343-1
8	Pump element, assy. ø 6 mm		x	1	650-28856-1
9	Sealing kit for pump element	x		1	550-36979-5
10	Hosing for low-level control	x		1	550-36981-3
11	Housing cover for low-level control plug 1A1.0	x		1	550-36984-1
11.1	Socket with 6 m cable for quarter turn type plug	x		1	664-34016-1
	Socket with 6 m cable for quarter-turn type plug,ADR	x		1	664-34016-3
11.2	Quart.-turn type plug	x		1	664-34016-2

Pos.	Designation	Kit	Part	Qty	Part No.
12	Printec circuit board 12/24 VDC	x		1	550-34019-2
13	Low-level control	x		1	550-36979-9
14	Motor, 12 VDC	x		1	550-36982-1
	Motor, 24 VDC	x		1	550-36982-2
14.1	Motor connection		x	1	664-36968-7
15	Hydr. lube fitting ST AR 1/8 Z		x	1	251-14040-1
16	Adapter M 22x1.5a x G 1/8 in.		x	1	304-19619-1
17	O-Ring ø 5 x1.5 mm		x	3	219-12222-2
18	SSV divider block				
	SSV V6 - K	x		1	619-37589-1
	SSV V12 - K	x		1	619-37590-1
	SSV V18 - K	x		1	619-37591-1
19	Hydr. lube fitting ST AR 1/8 Z		x	1	251-14040-1
20	Closure plug for control pin		x	1	519-32123-1
	Sealing kit for QLS			1	550-36979-8

Subject to modifications

**Declaration of conformity as defined by machinery directive 89/392/EEC Annex II A**

This is to declare that the design of the

**QLS 321 lubrication system**

in the version supplied by us, complies with the provisions of the directive 91/368/EEC

*Applied harmonized standards in particular*

- EN 292 - 1 Safety of machinery part 1  
Basic terminology, methodology
- EN 292 - 2 Safety of machinery part 2  
Technical principles and specifications
- EN 809 Pumps and pump units for liquids  
Safety requirements
- EN 60204-1 Safety of machinery  
Electrical equipment of machines  
Part 1: General requirements

**Declaration of conformity according EMV directive 89/336 EWG**

We declare that the model of the

**Centralized Lubrication System QLS 321**

in the version supplied by us, complies with the provisions of the above - mentioned directive

*Applied harmonized standards in particular*

- EN 55011 Specifications, limits and methods of measurement of radio disturbance characteristics of industrial, scientific and medical (ISM) radio-frequency equipment
- EN 50081-1 Electromagnetic compatibility  
Generic emission standard  
Part 1: residential, commercial and light industry
- EN 50082-2 Electromagnetic compatibility  
Generic emission standard  
Part 2: industrial environment

Walldorf, 16. 10. 2000, Dr. Ing. Z. Paluncic

Walldorf, 16. 10. 2000 , Dr. Ing. Z. Paluncic

**Americas:**

Lincoln Industrial  
One Lincoln Way  
St. Louis, MO 63120-1578  
(+1) 314 679 4200

**Europe/Africa:**

Lincoln GmbH  
Heinrich-Hertz Straße 2-8  
69190 Walldorf  
(+49) 6227 33-0

**Asia/Pacific:**

Lincoln Industrial  
Asia Pacific Regional Office  
25 International Business Park  
#01-65/67 German Centre  
Singapore 609916  
(+65) 562-7960



**A Pentair Company**

© Copyright 1999  
Printed in Germany  
Web site:  
[www.lincolnindustrial.com](http://www.lincolnindustrial.com)

Subject to modifications