

**OWNER/OPERATOR MANUAL**

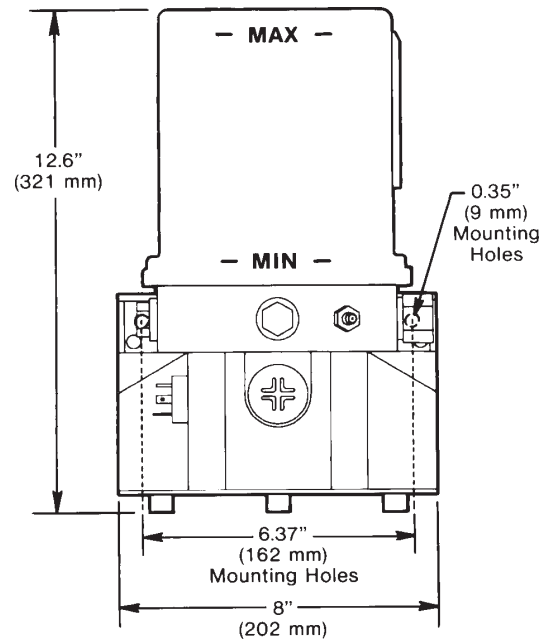
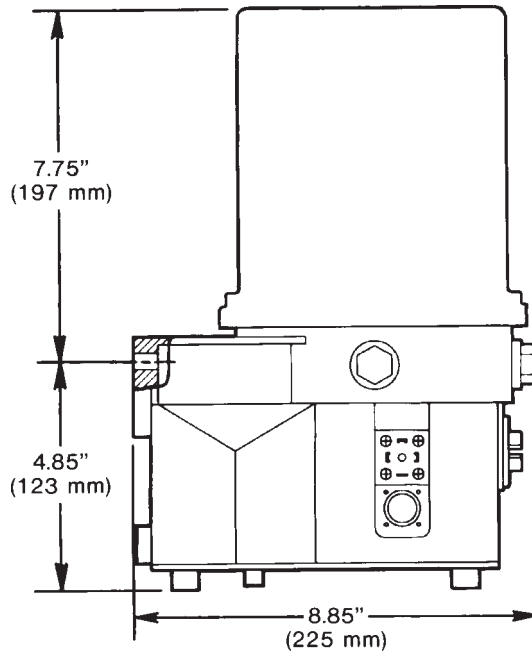

**WARNING**  
**Do Not use pump without pressure relief valve.**

**SPECIFICATIONS**

- Electrical Requirements ... 24 VDC @ 2 amps
- Enclosure Rating ..... IP 54 - Protected from water sprayed in all directions.
- On Time ..... 2 minutes minimum  
30 minutes maximum  
in 2 minute increments
- Off Time ..... 1 hour minimum  
15 hours maximum  
in 1 hour increments
- Pump Output ..... 0.146 cu. in./min (2.4 cm/min)
- Outlet Connection ..... 1/8" NPT (female)
- Maximum Recommended
  - Operating Pressure ..... 3600 psi (248 bar)
  - Reservoir Capacity ..... 122 cu. in. (2000 cc)
  - Lubricant ..... Greases up to NLGI grade 2 (depending on the operating temperature and type of lubricant)
- Temperature Range ..... - 13°F(-25°C) to +158°F(+70°C)
- Pressure Relief Valve ..... 4000 psi +/- 250 psi (276 bar) +/- (17 bar)

**DESCRIPTION**

The industrial lube pump is electrically operated and used in a progressive type centralized lubrication system. The pump consists of a pump housing, electric gear motor, a timer and a plastic reservoir with stirring paddle. The high operating pressure allows the pump to supply lubricant up to NLGI 2 grease.

**MOUNTING THE PUMP**

Select an easily accessible place of installation which allows access to the timer and lubricant reservoir filler fitting. The pump must be mounted vertically on an even surface by means of two bolts.

**TO FILL RESERVOIR**

Fill the reservoir through the grease fitting located at the base of the reservoir, using a hand operated grease pump. Refill reservoir when grease reaches "MIN" mark located on the reservoir. Fill the reservoir up to the "MAX" mark located on the reservoir.

**TO PRIME SYSTEM**

**Pump & Supply Line:** After reservoir has been filled with recommended lubricant, loosen the supply line fitting. Operate the pump until lubricant flows from outlet, then tighten fitting.

**Feed Lines:** Pre-fill each feed line with lubricant before connecting to outlet of divider valve and bearing.

## SYSTEM ACCESSORIES

Description	Qty.	Part No.
8 amp fuse	1	241052
8 amp fuse holder	1	241053

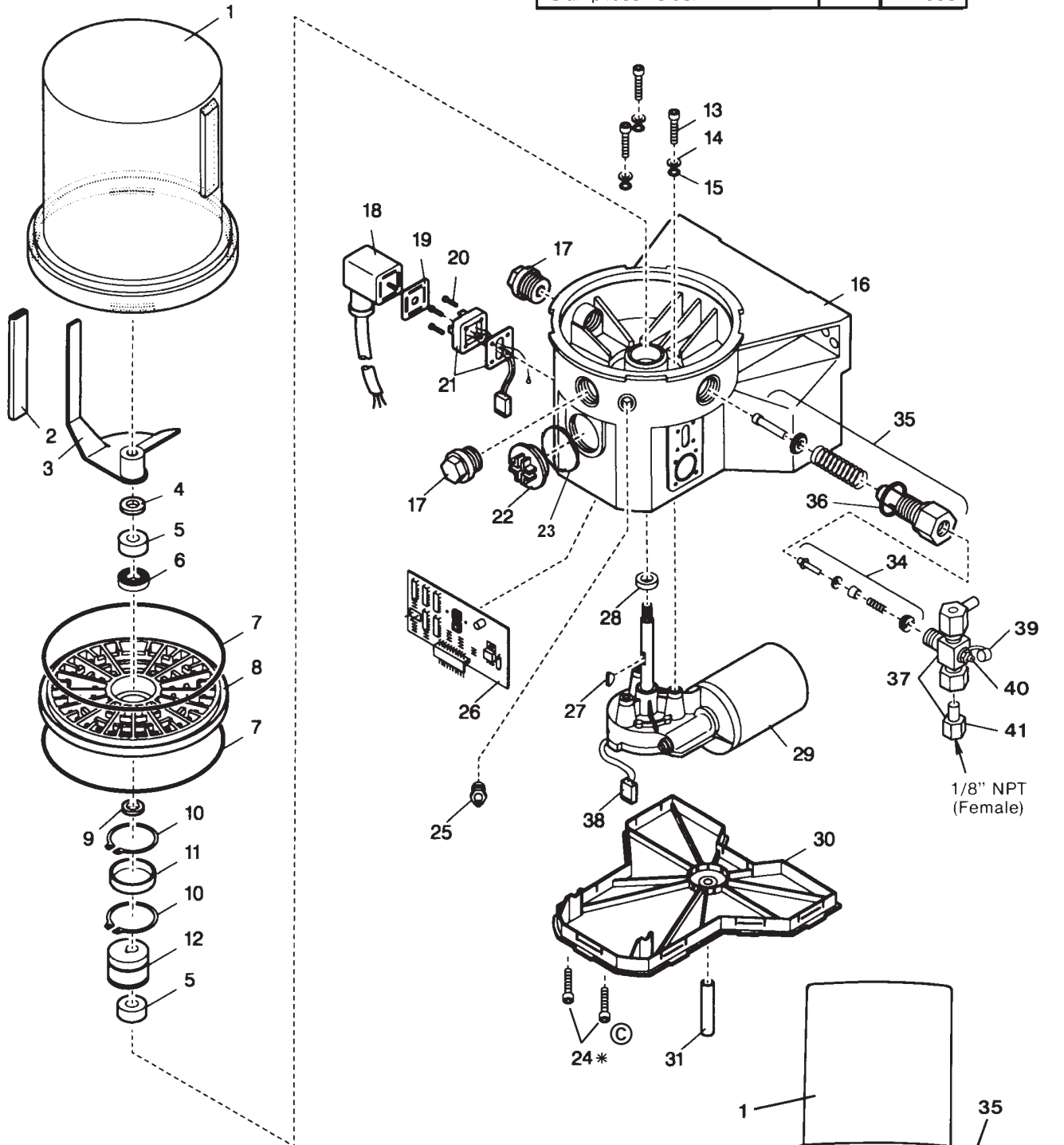

\* Only used on pumps  
Produced after December '96

© Indicates Change

- 1 Reservoir
- 18 Black Power Cord
- 22 Sealing Plug
- 25 Filler Grease Fitting
- 35 Pump Element Assembly
- 37 Pressure Relief Valve Assembly

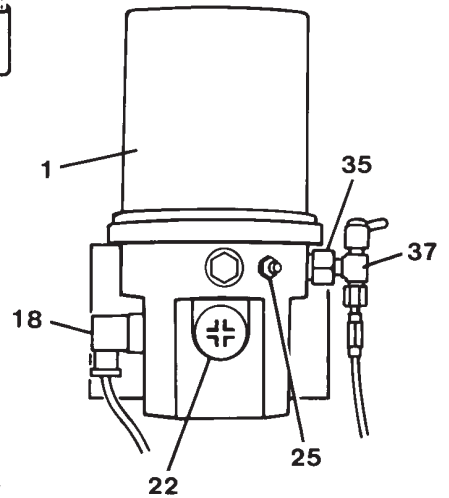

**ELECTRICAL CONNECTIONS**

Connect **black power cord** as follows:

**Red wire** connects to Off/On switch, to 8 amp fuse then to Battery (+).

**White wire** connects to Battery (-).

**Green wire** connects to grounding wire.

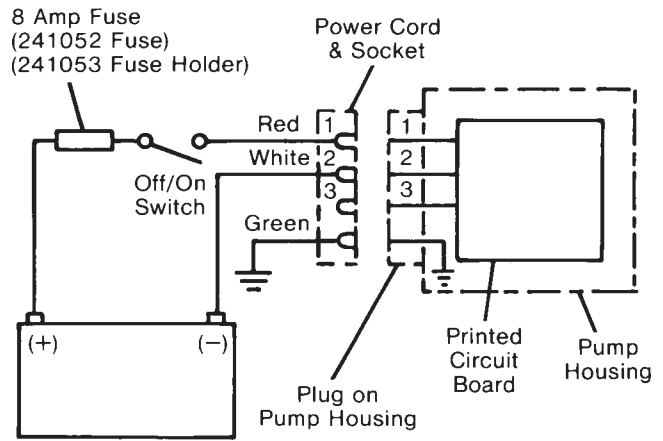

**PARTSLIST**

ITEM NO.	DESCRIPTION	QTY.	PART NUMBER /KIT NUMBER
1	Reservoir	1	part of Kit 246432
2	Hose	1	part of Kit 246433
3	Stirring paddle	1	part of Kit 246433
4	Washer	1	part of Kits 246433 & 246434
5	Bearing ring	2	part of Kit 246434
6	Bearing	1	part of Kit 246434
7	O-ring	2	246424, part of Kit 246432
8	Intermediate plate	1	246425
9	Shim	1	part of Kit 246434
10	Snap ring	2	part of Kit 246434
11	Inner ring	1	part of Kit 246434
12	Eccentric cam	1	246427
13	Screw	3	part of Kits 246435 & 246436
14	Washer	3	part of Kits 246435 & 246436
15	O-ring	3	part of Kits 246435, 246436 & 246437
16	Pump housing	1	246426
17	Closure plug	2	246422
18	Socket with cord	1	part of Kits 246430
19	Flat packing	1	part of Kits 246430, 246550
20	Screws	4	part of Kit 246550
21	Plug	1	part of Kit 246550
22	Sealing plug	1	246423
23	O-ring	1	219141382
24	Screw	2	206137967©
25	Grease fitting	1	5050
26	Printed circuit board	1	246420
27	Woodruff key	1	part of Kits 246435 & 246436
28	Radial seal	1	part of Kits 246435, 246436 & 246437
29	12 VDC motor	1	part of Kit 246435
29	24 VDC motor	1	part of Kit 246436
30	Housing cover	1	246421
31	Hose	1	Not sold
32	NOT ASSIGNED		
33	NOT ASSIGNED		
34	Check valve	1	part of Kit 600268762
35	Pump element	1	part of Kit 600268762
36	Gasket	1	part of Kit 600268762
37	Pressure relief assy.	1	246321
38	Plug for motor	1	part of Kits 243435 & 246436
39	Grease cap	1	242125
40	Grease fitting	1	5045
41	Adapter for relief assy.	1	246428

©Indicates Change

## TIMER OPERATION

When the Off timer reaches the preset value the pump will turn on. The pump remains activated for the period of time that is preset on the On timer.

If power to the pump is interrupted, the Off timer will retain the accumulated time for a period of five days. When power is turned back on during the five day period, the off time will resume timing from the accumulated time it reached prior to the power interruption. If power is not restored before the end of the five day period, timer will begin with an On period.

Remove Sealing Plug (Item 22) to access manual lube switch, timer adjustments or to view the system LED's.

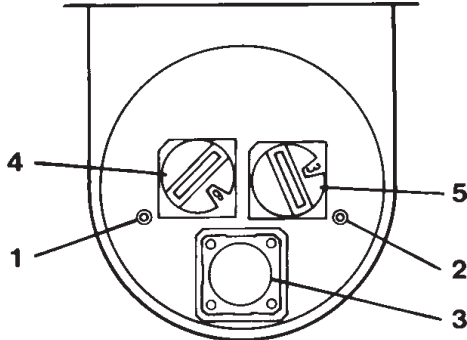

1. The LED marked "battery" lights when power is applied to the PC board.
2. The LED marked "motor" lights when pumping lubricant.
3. Depressing pushbutton for 2 seconds will initiate a manual lube event.
4. Off time rotary switch. Can be adjusted to 15 values (see chart below).
5. On time rotary switch. Can be adjusted to 15 values (see chart below).

**IMPORTANT:** Do Not use the Zero position located on the Off time and On time switches.

Off-Time Rotary Switch Setting	Interval Between Lube Cycles	On-Time Rotary Switch Setting	Pump will run for:
0	Will not run	0	Will not run
1	1 hour	1	2 minutes
2	2 hours	2	4 minutes
3	3 hours	3	6 minutes
4	4 hours	4	8 minutes
5	5 hours	5	10 minutes
6	6 hours	6	12 minutes
7	7 hours	7	14 minutes
8	8 hours	8	16 minutes
9	9 hours	9	18 minutes
A	10 hours	A	20 minutes
B	11 hours	B	22 minutes
C	12 hours	C	24 minutes
D	13 hours	D	26 minutes
E	14 hours	E	28 minutes
F	15 hours	F	30 minutes

## SERVICE PARTS/KITS

PART NO.	QTY.	DESCRIPTION	ITEM NO.
5045	1	Grease fitting	40
5050	1	Grease fitting	25
242125	1	Grease cap	39
246321	1	Pressure relief assembly	37
246420	1	Printed circuit board	26
246421	1	Housing cover	30
246422	1	Closure plug	17
246423	1	Sealing plug	22
246424	2	O-ring	7
246425	1	Intermediate plate	8
246426	1	Pump housing	16
246427	1	Eccentric cam	12
246428	1	Adapter for relief assembly	41
246430	1	Power Cord Kit contains:	
	1	Socket with cord	18
	1	Flat packing	19
246433	1	Paddle Kit contains:	
	1	Hose	2
	1	Stirring paddle	3
	1	Washer	4
246434	1	Bearing & Seal Kit contains:	
	1	Washer	4
	2	Bearing ring	5
	1	Bearing	6
	1	Shim	9
	2	Snap ring	10
	1	Inner ring	11
246436	1	24 VDC Motor Kit contains:	
	3	Screw	13
	3	Washer	14
	3	O-ring	15
	1	Woodruff key	27
	1	Radial seal	28
	1	24 VDC motor	29
	1	Plug for motor	38
246437	1	Housing Seal Kit contains:	
	3	O-ring	15
	1	Radial seal	28
246440	1	Power Plug Kit contains:	
	1	Flat packing	19
	4	Screws	20
	1	Plug	21
246644	1	Printed circuit board	26
206137967	2	Screw©	24
219141382	1	O-ring	23
600268762	1	Pump Element Assembly contains:	
	1	Check valve	34
	1	Pump element	35
	1	Gasket	36

©Indicates Change

### RETAIN THIS INFORMATION FOR FUTURE REFERENCE

When ordering replacement parts, list: Part Number, Description, Model Number and Series Letter.  
LINCOLN provides a Distributor Network that stocks equipment and replacement parts.