

OWNER/OPERATOR MANUAL

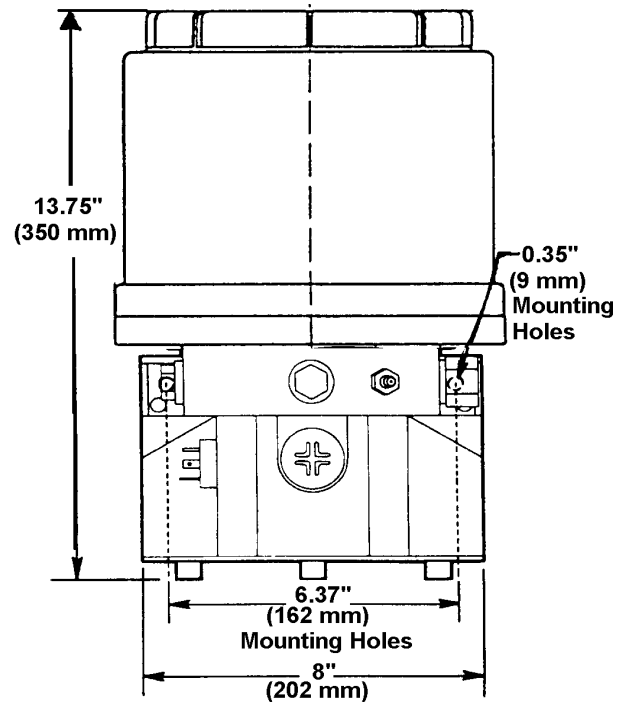
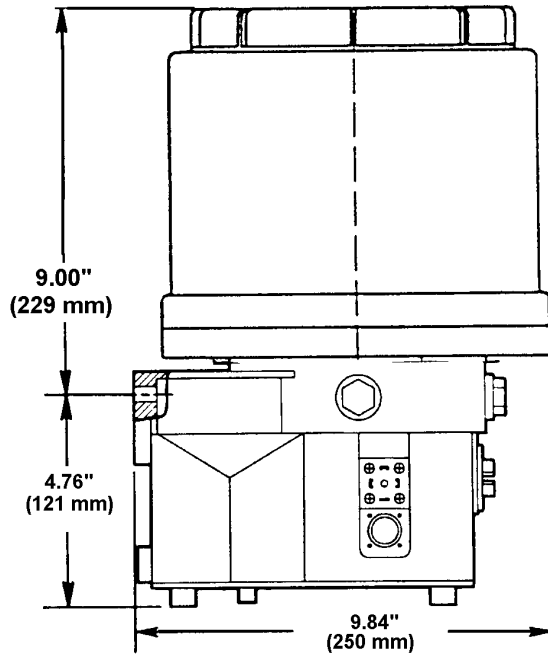

SPECIFICATIONS

Electrical Requirements

Model 94412	12 VDC @ 3.5 amps
Model 94424	24 VDC @ 2 amps
Enclosure Rating	IP 54 - Protected from water sprayed in all directions.
On Time	2 minutes minimum 30 minutes maximum in 2 minute increments
Off Time	1 hour minimum 15 hours maximum in 1 hour increments
Pump Output	0.146 cu. in./min (2.4 cm/min)
Outlet Connection	1/8" NPT (female)
Maximum Recommended	
Operating Pressure	3600 psi (248 bar)
Reservoir Capacity	244 cu. in. (4000 cc)
Lubricant	Greases up to NLGI grade 2 (depending on the operating temperature and type of lubricant)
Temperature Range	- 13°F(-25°C) to +158°F(+70°C)
Pressure Relief Valve	4000 psi +/- 250 psi (276 bars) +/- (17 bars)

DESCRIPTION

The chassis lube pump is electrically operated and used in a progressive type centralized lubrication system. The pump consists of a pump housing, electric gear motor, a timer and a plastic reservoir with stirring paddle. The high operating pressure allows the pump to supply lubricant up to NLGI #2 grease.

MOUNTING THE PUMP

Select an easily accessible place of installation which allows access to the timer and lubricant reservoir filler fitting. The pump must be mounted vertically on an even surface by means of three bolts.

TO FILL RESERVOIR

Fill the reservoir through the grease fitting located at the base of the reservoir, using a hand operated grease pump. Refill reservoir when grease reaches "MIN" mark located on the reservoir. Fill the reservoir up to the "MAX" mark located on the reservoir.

TO PRIME SYSTEM

Pump & Supply Line: After reservoir has been filled with recommended lubricant, loosen the supply line fitting. Operate the pump until lubricant flows from outlet, then tighten fitting.

Feed Lines: Pre-fill each feed line with lubricant before connecting to outlet of divider valve and bearing.

SYSTEM ACCESSORIES

Description	Qty.	Part No.
8 amp fuse	1	241052
8 amp fuse holder	1	241053
Lighted manual switch (12 VDC)	1	241419
Lighted manual switch (24 VDC)	1	241484
Remote manual lube kit	1	246322

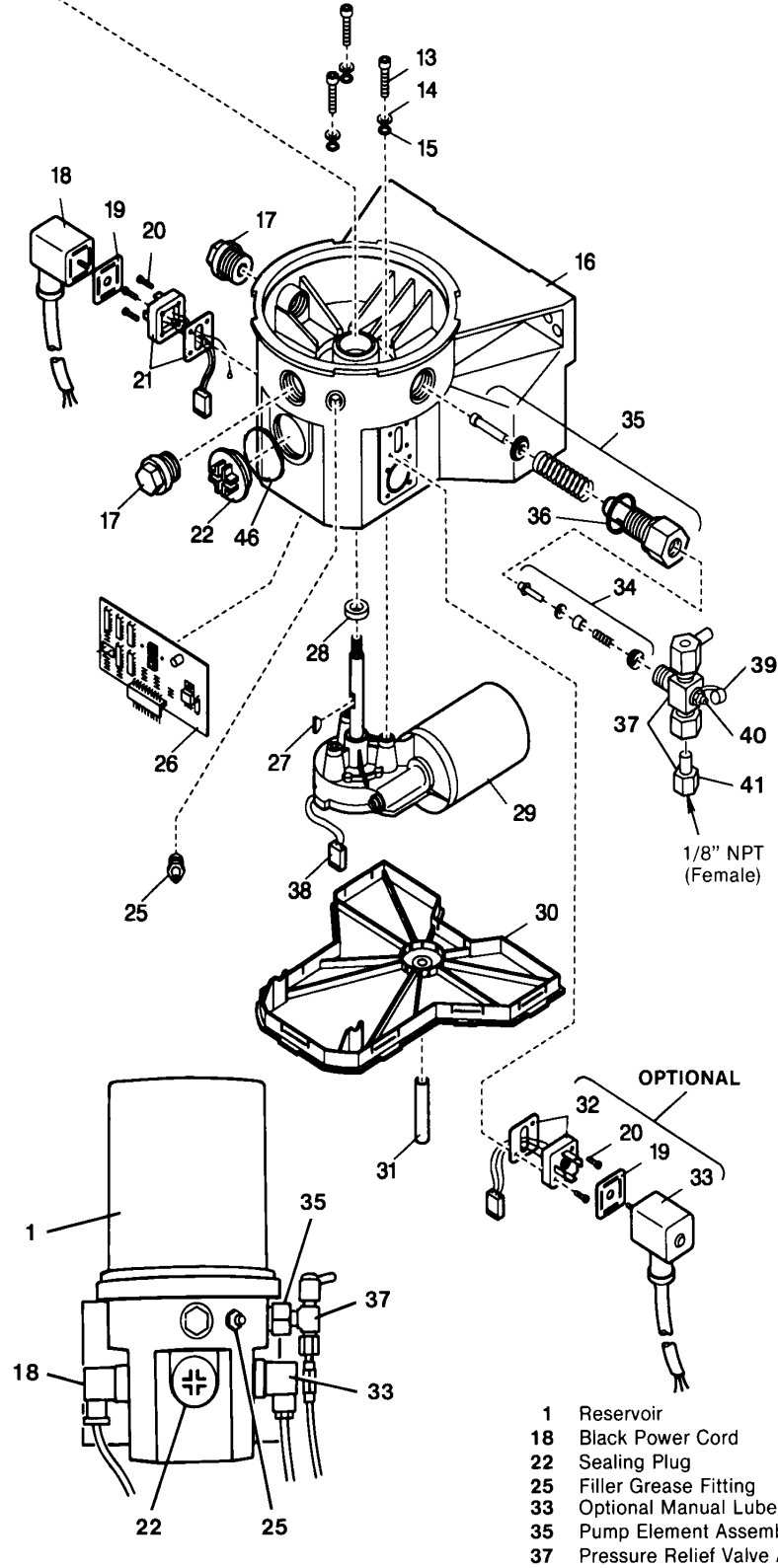
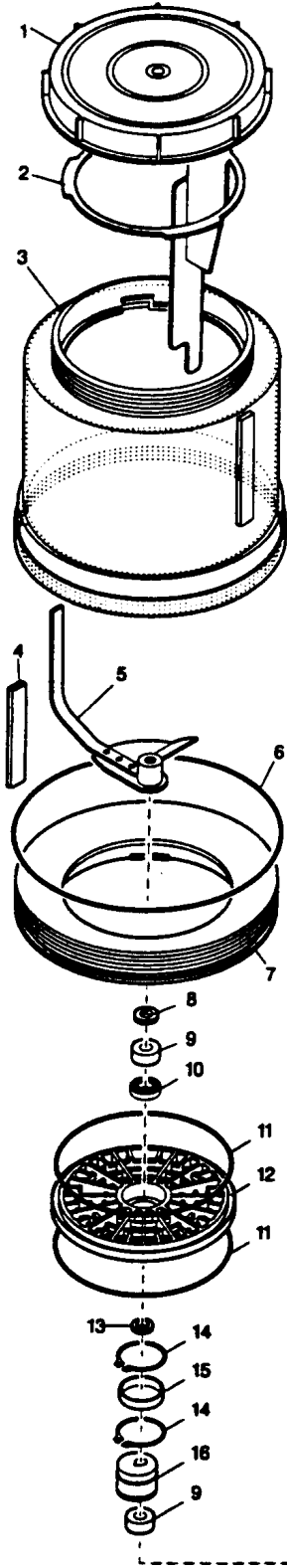

*Only Used On Pumps
Produced After December '96

- 1 Reservoir
- 18 Black Power Cord
- 22 Sealing Plug
- 25 Filler Grease Fitting
- 33 Optional Manual Lube Cord
- 35 Pump Element Assembly
- 37 Pressure Relief Valve Assembly

ELECTRICAL CONNECTIONS

Connect black power cord as follows:

Red wire connects to Off/On switch, to 8 amp fuse then to Battery (+).

White wire connects to Battery (-).

Green wire connects to grounding wire.

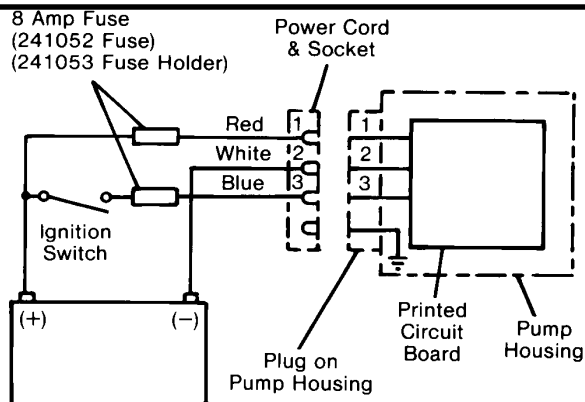

PARTS LIST

ITEM NO.	DESCRIPTION	QTY.	PART NUMBER /KIT NUMBER
1	Reservoir	1	247673
2	Hose	1	247676
3	Stirring paddle	1	247675
4	Washer	1	247679
5	Bearing ring	2	part of kit 246434
6	Bearing	1	part of kit 246434
7	O-ring	2	246424
8	Intermediate plate	1	246425
9	Shim	1	part of kit 246434
10	Snap ring	2	part of kit 246434
11	Inner ring	1	part of kit 246434
12	Eccentric cam	1	246427
13	Screw	3	part of kits 246435& 246436
14	Washer	3	part of kits 246435 & 246436
15	O-ring	3	part of kits 246435, 246436 & 246437
16	Pump housing	1	246426
17	Closure plug	2	246422
18	Socket with cord	1	part of kits 246429
19	Flat packing	1	part of kits 246429, 246440, 246441, & 246431
20	Screws	4	part of kits 246440 & 246441
21	Plug	1	part of kits 246440
22	Sealing plug	1	246423
23	Nipple	1	226141055
24	Screw	2	206137967
25	Grease fitting	1	5050
26	Printed circuit board	1	246420
27	Woodruff key	1	part of kits 246435 & 246436
28	Radial seal	1	part of kits 246435, 246436 & 246437
29	12 VDC motor	1	part of kit 246435
29	24 VDC motor	1	part of kit 246436
30	Housing cover	1	246421
31	Hose	1	not sold
32	Plug	1	part of kit 246441
33	Socket	1	part of kit 246431
34	Check valve	1	part of kit 600268762
35	Pump element	1	part of kit 600268762
36	Gasket	1	part of kit 600268762
37	Pressure relief assembly	1	246321
38	Plug for motor	1	part of kits 246435 & 246436
39	Grease cap	1	242125
40	Grease fitting	1	5045
41	Adapter for relief assembly	1	246428
42	Lid	1	247671
43	Fixed paddle	1	247664
44	O-ring	1	247677
45	Adapter	1	247678
46	O-ring	1	219141382

REMOTE MANUAL LUBE PUSHBUTTON

If a remote manual lube pushbutton is required, order a 246322 Manual Lube Kit (consisting of a 32 ft. cord and plug) and:

for a 12 volt pump, order
241419 - Lighted Manual Lube Switch

for a 24 volt pump, order
241484 - Lighted Manual Lube Switch

IMPORTANT:

When using a Model 94412 or 94424 to replace an old style 103 pump with remote manual lube switch, only the 246322 Manual Lube Kit is required.

The wiring for the remote light used on the 103 pump must be changed for the new Models 94412 and 94424. The existing wire that connects the light to the Battery (-) must be disconnected. Reconnect it to the Battery (+).

MOUNTING HOLE LOCATIONS

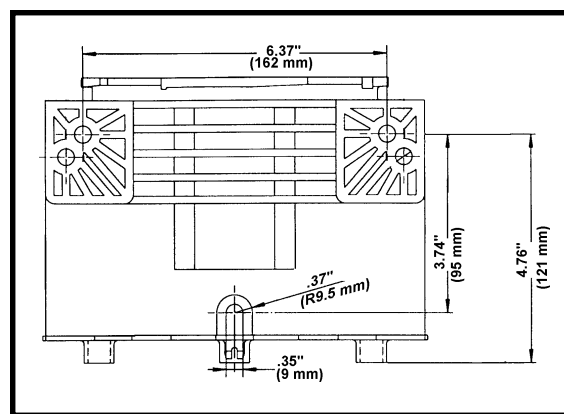

Fig. 1

TIMER OPERATION

The Off timer begins accumulating time when the ignition switch closes. When the Off timer reaches the preset value, the pump will turn on. The pump remains activated for the period of time that is preset on the On timer.

When the ignition switch opens, the Off timer will retain its accumulated time for a period of five days. When the ignition switch closes during the five dayperiod, the Off timer will resume timing from the accumulated time it reached prior to the ignition switch opening. If ignition switch is not closed before the end of five day period, timer will begin with an On period.

Remove Sealing Plug (Item 22) to access manual lube switch, timer adjustments or to view the system LED's.

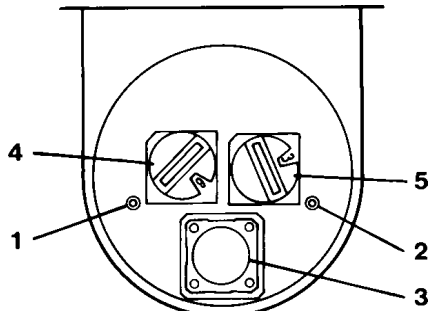

1. The LED marked "battery" lights when power is applied to the PC board.
2. The LED marked "motor" lights when pumping lubricant.
3. Depressing pushbutton for 2 seconds will initiate a manual lube event.
4. Off time rotary switch. Can be adjusted to 15 values (see chart below).
5. On time rotary switch. Can be adjusted to 15 values (see chart below).

IMPORTANT: Do Not use the Zero position located on the Off time and On time switches.

Off-Time Rotary Switch Setting	Interval Between Lube Cycles	On-Time Rotary Switch Setting	Pump will run for:
0	Will not run	0	Will not run
1	1 hour	1	2 minutes
2	2 hours	2	4 minutes
3	3 hours	3	6 minutes
4	4 hours	4	8 minutes
5	5 hours	5	10 minutes
6	6 hours	6	12 minutes
7	7 hours	7	14 minutes
8	8 hours	8	16 minutes
9	9 hours	9	18 minutes
A	10 hours	A	20 minutes
B	11 hours	B	22 minutes
C	12 hours	C	24 minutes
D	13 hours	D	26 minutes
E	14 hours	E	28 minutes
F	15 hours	F	30 minutes

SERVICE PARTS/KITS

PART NO.	QTY.	DESCRIPTION	ITEM NO.
5045	1	Grease fitting	40
5050	1	Grease fitting	25
242125	1	Grease cap	39
246321	1	Pressure relief assembly	37
246420	1	Printed circuit board	26
246421	1	Housing cover	30
246422	1	Closure plug	17
246423	1	Sealing plug	22
246424	2	O-ring	7
246425	1	Intermediate plate	8
246426	1	Pump housing	16
246427	1	Eccentric cam	12
246428	1	Adapter for relief assembly	41
246429		Power Cord Kit contains:	
	1	Socket with cord	18
	1	Flat packing	19
246431		Optional Manual Lube Cord Set contains:	
	1	Flat packing	19
	1	Socket with cord	33
246434		Bearing & Seal Kit contains:	
	1	Washer	4
	2	Bearing ring	5
	1	Bearing	6
	1	Shim	9
	2	Snap ring	10
	1	Inner ring	11
246435		12 VDC Motor Kit contains:	
	3	Screw	13
	3	Washer	14
	3	O-ring	15
	1	Woodruff key	27
	1	Radial seal	28
	1	12 VDC motor	29
	1	Plug for motor	38
246436		24 VDC Motor Kit contains:	
	3	Screw	13
	3	Washer	14
	3	O-ring	15
	1	Woodruff key	27
	1	Radial seal	28
	1	24 VDC motor	29
	1	Plug for motor	38
246437		Housing Seal Kit contains:	
	3	O-ring	15
	1	Radial seal	28
246440		Power Plug Kit contains:	
	1	Flat packing	19
	4	Screws	20
	1	Plug	21
246441		Optional Manual Lube Plug Set contains:	
	1	Flat packing	19
	4	Screws	20
	1	Plug	32
247664	1	Fixed paddle	43
247671	1	Lid	42
247673	1	Reservoir	1
247675	1	Stirring paddle	3
247676	1	Hose	2
247677	1	O-ring	44
247678	1	Adapter	45
247679	1	Washer	4
219141382	1	O-ring	46
226141055	1	Nipple	23
600268762		Pump Element Assembly contains:	
	1	Check valve	34
	1	Pump element	35
	1	Gasket	36

RETAIN THIS INFORMATION FOR FUTURE REFERENCE

When ordering replacement parts, list: Part Number, Description, Model Number and Series Letter.
LINCOLN provides a Distributor Network that stocks equipment and replacement parts.