**HYDRAULIC HAMMER PUMP
MODEL 85429
Series "B"**

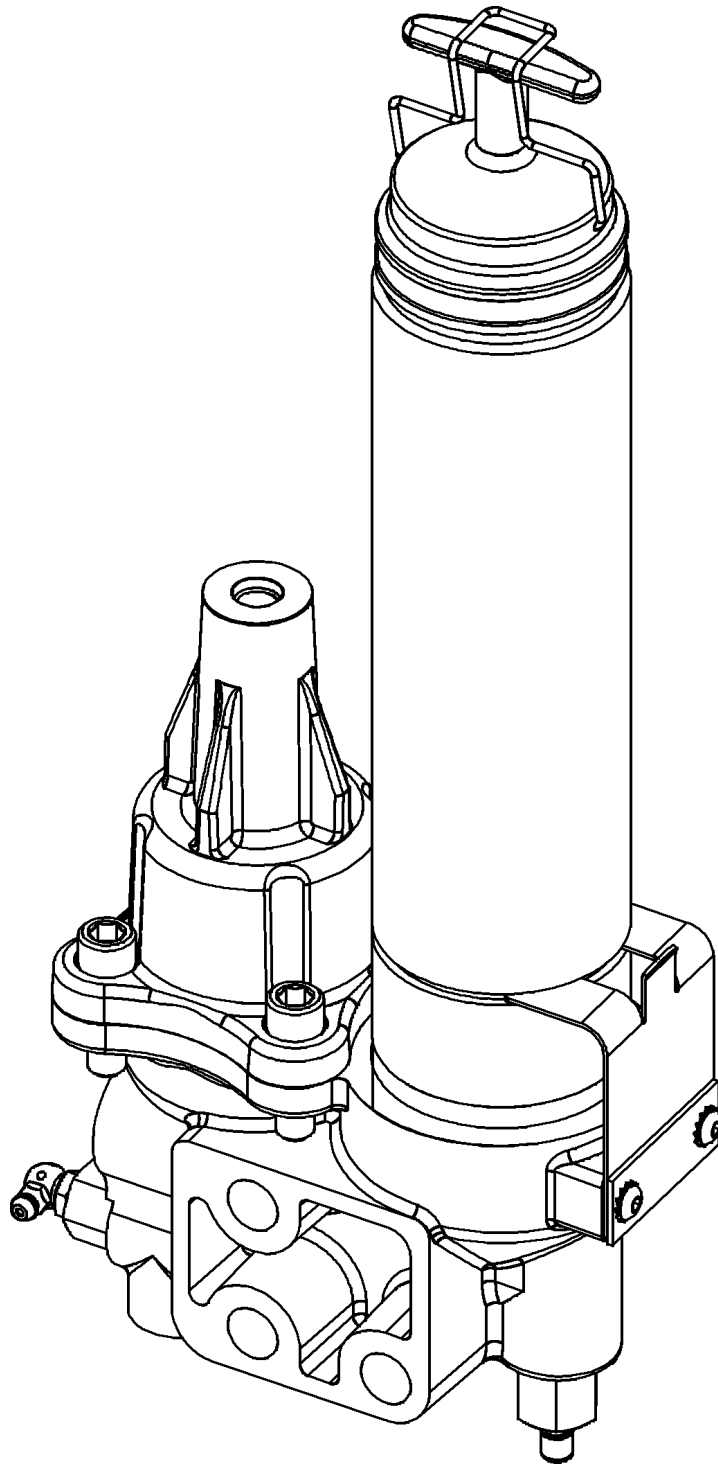

Table of Contents

	Page
Safety.....	2
General Description.....	2
Appropriate Use.....	2
Product Specifications.....	2
Pump Operation.....	3
Excavators and Backhoes.....	3
Skid Steers.....	3
Lubricant Recommendations.....	3
Pump Output Adjustment.....	3
Pump Filling.....	3
Maintenance and Repair.....	3
Installing Grease Cartridge.....	4
Manual (Bulk) Filling.....	4
Air Purging.....	4
Installing the Pump.....	4
Filling Pump with Lubricant, Removing Empty Cartridge.....	5
Return Spring Adjustment Procedure.....	5
Disassembly Procedure.....	5
Pump Dimensions.....	6
Pump Cut-Aways.....	7&8
Pump Exploded View.....	9
Repair Parts List.....	10
Trouble Shooting.....	11

Safety

Read and carefully observe these operating instructions before unpacking and operating the pump. The pump must be operated, maintained and repaired exclusively by persons familiar with the operating instructions. Local safety regulations regarding installation, operation and maintenance must be followed.

Operate this pump only after safety instructions and this service manual are fully understood.

WARNING

Indicates a potentially hazardous situation which, if not avoided, could result in death or serious injury.

CAUTION

Indicates a potentially hazardous situation which, if not avoided, may result in minor or moderate injury.

Safety Instructions

This equipment generates very high grease pressure. Extreme caution should be used when operating this equipment as material leaks from loose or ruptured components can inject fluid through the skin and into the body causing serious bodily injury. Adequate protection is recommended to prevent splashing of material onto the skin or into the eyes.

WARNING

If any fluid appears to penetrate the skin, get emergency medical immediately. Do not treat as a simple cut. Tell attending physician exactly what fluid was injected.

Description

General Description

This unit is a hydraulically operated, single acting, spring return, positive displacement pump designed to deliver grease under pressure. The pump is primarily designed to lubricate bushings of the tool bit in Hydraulic Hammers. The pump can be used to lubricate bushings and bearings on grippers and crushers. The pump is designed to be directly installed on the hammer, gripper or crusher and connected to the hydraulic power supply of the carrier. Grease outlet of the pump should be connected by hose to the point of lubrication.

The pump could be attached to an SSV divider block for multiple point lubrication.

The pump uses grease from standard 14.5 oz. grease cartridges, eliminating the need for bulk filling equipment. The pump may be filled from a bulk lubricant container if desired.

Appropriate Use

- This pump is exclusively designed to dispense grease in Hydraulic Hammer and gripper/crusher applications.
- It should be operated only with hydraulic power.
- The maximum ratings given should not be exceeded.
- Any other use not in accordance with the instructions will result in loss of claims for warranty and liability.

Product Specification

Pump Ratio, Max.	2.16:1
Output per Stroke,	0.006 in ³ (0.1 cm ³)*
Hydraulic Inlet	
Pressure (max.)	3,000 PSIG (208 bar)
Grease Reservoir Vol.	14.5 oz.
Max Inlet Back Pressure	725 PSIG (49.3 bar)
Output Pressure (max.)	6500 PSIG (450 bar)
Operating Temperature	-10° F to +180° F (-23°C to +80°C)
Hydraulic Port	SAE #4 (7/16-20 UNF) O-Ring
Pump Outlet	SAE #4 (7/16-20 UNF) O-Ring
Weight (empty)	16.3 lbs. (7.4 kg)
Weight (full)	17.3 lbs. (7.8 kg)

* **NOTE:** Pump output can be increased up to 0.031 in³ (0.5 cm³) by replacing the metering plug (23). See "Pump Output Adjustment."

HYDRAULIC HAMMER PUMP MODEL 85429 Series "B"



Pump Operation

The pump operates simultaneously with the hammer. Each time the hammer is activated, the pump will deliver one shot of the lubricant to the bushing of the hammer. The pump is a single action pump and delivers the lubricant only on the forward stroke of the piston 6, Illus. #2. The springs 8, 9, and 10 will return the piston 6 to initial position, recharging the pump. The springs of the pump can develop the force to overcome 725 PSIG (49 bar) back pressure. This limiting factor of the pump should be taken into consideration during pump installation on the different types of the hammer carriers.

The installation of the pump requires connection of the pressure hydraulic line from the carrier to the pump inlet and grease supply line from the pump outlet to the hammer lubrication point.

The carriers have different hydraulic systems to operate the machines and attachments. Depending on the type of the carrier, hydraulic lines can vent the pressure very quickly or have residual back pressure above 725 PSIG (49 bar) retained in the lines for a long time.

Excavators and Backhoes

Main pressure of the hydraulic power supply of the excavators and the backhoes drops below 725 PSIG (49 bar) very rapidly when hammer is stopped. This will allow the spring to return the piston to recharge the pump.

Connect the Pump to the Pressure Line. The pump will cycle and deliver the lubricant as soon as the hammer starts to operate. During the repositioning of the hammer to a new location, the springs will return the piston to recharge the pump for a new cycle. The lubrication of the hammer is done during the hammer operation.

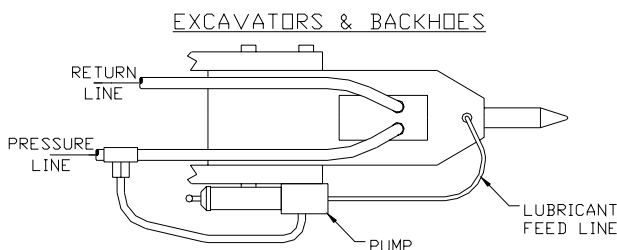

Skid Steers

Skid steers with hydrostatic transmissions have a back pressure in the return line, since hydraulic fluid returned to the tank through the transmission itself. The hydrostatic transmission is used to drive the skid steer using hydraulic power generated by diesel motor. The back pressure in the return line can vary from 350 to 1,200 PSIG (24 to 82 bar) depending on the skid steer manufacturer, but quickly drops to 50 PSIG (3.5 bar) or below during hammer operation.

Connect the pump to the return line. The pump will deliver the lubricant using the back pressure when hammer stops to operate and will recharge during the hammer operation

when the pressure drops. So, the lubrication is done during hammer repositioning to new location and pump will recharge during hammer operation, this is opposite of the lubrication cycle of the excavators and backhoes.

The connection of the pump to the carrier will depend only on the type of the carrier and will not be dependent on the type or manufacturer of the hammer:

Carrier Type	Connection Lines
Excavator, Backhoe	Pressure line
Skid Steers	Return Line

Regardless of the pump connection to the pressure or return line, if pressure fluctuation during the hammer operation falls below 725 PSIG (49 bar) the pump can deliver a small amount of lubricant due to the piston partial movement. This additional lubricant output has to be taken into consideration during selection of the Output Plug (23), Illus. #4. to adjust the lubricant output.

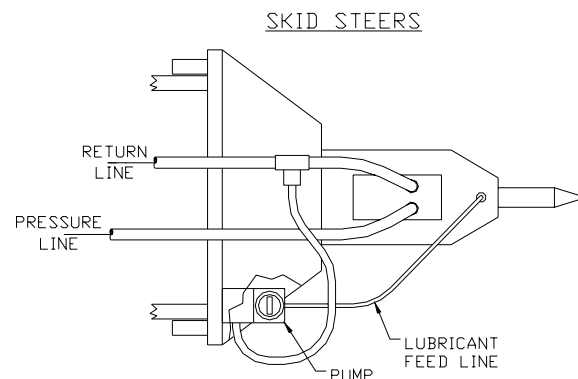

Lubricant Recommendations

Hammer manufacturers recommend lubricating while the hammer is standing upright, resting on the tool to ensure that the grease will penetrate downward between the tool and the bushing. This recommendation is important when lubrication is made using the manual grease gun and a large amount of lubricant pumped into the hammer. The upright position of the hammer with tool in a resting position will ensure that the space between the piston and the tool not be filled with the lubricant. Automatic lubrication with the single stroke pump injects a very small amount of lubricant during hammer operation and there is no need for the hammer tool to be in a resting position.

How much lubrication is enough? The pump output should be adjusted to make the length of the tool shank that is traveling in and out of the bushing visibly "wet" with lubricant. Do not over lubricant to the point that grease is clumping and runs down on the tool.

Pump Output Adjustment

The pump is shipped with the minimum output metering plug 23, Illus. #4. The plug output is 0.006 in³ (0.1 cm³). The output of the pump can be increased by replacing the metering plug with one of the optional plugs below:

HYDRAULIC HAMMER PUMP

MODEL 85429

Series "B"



1. 271924 - 0.031 in³ (0.5 cm³)
2. 271925 - 0.018 in³ (0.3 cm³)
3. 271926 - 0.012 in³ (0.2 cm³)
4. 271927 - 0.006 in³ (0.1 cm³)

INSTALLING THE PUMP

The pump should be installed directly on the hammer or the carrier adapter for the hammer or attachment. It is preferable to mount the pump so that the cartridge housing (28) is in the upright position (as shown on the front page), but horizontal positioning is acceptable. Allow sufficient space for cartridge changing and service. (See Fig. #2 for dimensions). The red low-level indicator (18) should be readily visible. mount the pump in a position that it will be protected from damage by any debris which may be encountered when the hammer or attachment is in operation.

IMPORTANT: The feed line to the lube point must also be protected from damage by armoring the line or other suitable method of protection.

1. Lincoln recommends using **Grade 8** fasteners, or equivalent, for mounting the pump to the hammer or adapter. It is important that two flat washer are used between the bolt head or nut and the pump body of each fastener. 1/2" grade 8 bolts, nuts and flat washer are recommended. Apply 120 ft.-lbs. torque to the fasteners. Fabricate a mounting bracket if necessary.
2. Using appropriate high-pressure hose, connect the pump hydraulic inlet to the source of hydraulic power. This may be either the supply or return lines to the hammer. See above.
3. Fill the pump with lubricant. (See FILLING PUMP WITH LUBRICANT AND AIR PURGING INSTRUCTIONS.)
4. Attach the lubricant feed line to the lube outlet on the pump.
5. Prime the lubricant feed line with lubricant.
6. Connect the lubricant feed line to the lube point. This should be a direct connection, avoiding any grease fitting couplers of possible.
7. Protect the lubricant feed line from damage by covering with steel channel or angle iron if necessary.

IMPORTANT: The Low Level Indicator Rod (14) will extend from the bottom of the pump when the grease cartridge housing is empty. See (Fig. # 3, View D) Replace empty cartridge or fill cartridge housing promptly with fresh lubricant.

Adjusting the Spring Clip

For the Spring Clip (32) to properly retain the grease cartridge housing (28), it must be properly adjusted for either bulk or cartridge filling. If the pump is to be used with grease cartridges, the spring clip (32) must be adjusted to fit tightly in the groove when a grease cartridge installed is in the grease cartridge housing (28). If the pump is to be bulk filled or filled with a pump, the spring clip should be

adjusted to fit into the groove tightly with no grease cartridge installed in the cartridge housing (28). See Illus. #3, View A. Refer to appropriate section for details on adjustment.

Maintenance and Repair

Relieve pressure from the pump and supply lines before servicing or repairing the pump, to reduce the risk of an injury from injection, splashing fluid or moving parts.



Always use Lincoln Industrial parts for service and repair.

Filling Pump with Grease Removing Empty Cartridge

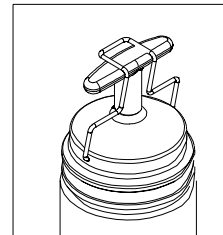

1. Disengage the retaining clip from the follower handle as shown in the illustration, below.
2. Pull the spring clip of the reservoir retainer by grasping the finger tab on the clip and disengage the clip fingers from the housing groove. Loosen the Grease Cartridge Housing a couple of turns to break the seal.
3. Pull back the follower handle until the follower rod is fully extended and latch the follower rod groove into the slot in the tube cap.
4. Unscrew the grease cartridge housing (28) from the pump head (11).
5. Carefully release the follower handle to eject the empty cartridge from the container tube.

Installing Grease Cartridge

1. Visually check follower seal lip direction before loading a new cartridge. The follower seal lip must be directed toward the follower handle for cartridge loading. See illustration below. To change the direction of the follower seal, unscrew the tube cap from the container tube and pull on handle to remove the follower seal from the tube. Flip the follower seal over and re-assemble.
2. Pull back on the follower handle and latch the follower rod groove into the slot on the tube cap.
3. Remove the plastic cap from the grease cartridge and insert the cartridge into the container tube.
4. Remove the pull-tab from the grease cartridge. Pull the finger tab on the spring retainer (31) back to clear the grease cartridge housing (28) as the housing is placed into the opening in the pump head (11). Screw grease cartridge housing (28) into the pump head (11) and tighten.
5. Release follower rod from slot. Purge air from pump. See air-purging instructions.
6. Latch the retaining clip over the top of the follower handle to prevent the follower rod from protruding from the grease cartridge housing.

HYDRAULIC HAMMER PUMP MODEL 85429 Series "B"



7. If installing a grease cartridge for the first time, see Installing the Reservoir Retainer, above for proper adjustment.

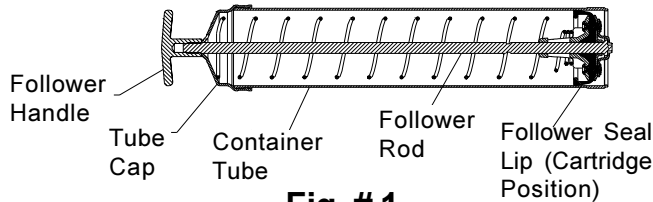

Fig. #1

Manual (Bulk) Filling

1. Pull the spring clip of the reservoir retainer by grasping the finger tab on the clip and disengage the clip fingers from the housing groove while unscrewing the Grease Cartridge Housing (28) from the Pump Head (11).
2. The follower seal lip must be directed towards the pump head when cartridges are not used. To change direction of the follower, unscrew tube cap from container tube and pull on handle to remove follower from tube. Flip follower seal over and re-assemble.
3. Pack the follower end of the container tube with grease to eliminate air pockets.
4. Dip the packed end of the container tube about one inch into bulk container.
5. Slowly pull follower handle back while gradually pushing the container tube deeper into the grease,
6. When the follower rod is fully extended, latch the groove in the follower rod with the slot in the reservoir cap.
7. Wipe excess grease from the outside of the container tube.
8. Pull the finger tab on the spring retainer (31) back to clear the grease cartridge housing (28) as the housing is placed into the opening in the pump head (11). Screw grease cartridge-housing (28) into the pump head (11) and tighten.
9. Adjust the spring retainer as required, see Installing the Reservoir Retainer.
10. Latch the retaining clip over the top of the follower handle to prevent the follower rod from protruding from the grease cartridge housing.

Air Purging

1. Engage the follower rod with the follower by lightly pulling up and rotating the follower handle.
2. Push down on follower handle while pressing button on Vent Valve (12) to force any air pockets out of Pump Head (11).
3. Wipe excess grease from Vent Valve (12).

Bulk Filling with Filler Pump

1. Remove Vent Fitting (12) and replace with Grease Fitting 5003 (29), included in package.
2. The follower seal lip must be directed toward the pump head when cartridges are not used.
3. Engage the follower rod with the follower by lightly pulling up and rotating the follower handle.
4. Push filler pump socket onto filler nipple.

5. Operate filler pump to fill container tube while watching follower rod. The container is full when notch on follower rod becomes visible.
6. Disengage follower rod from follower and push follower rod into container tube. Air purging is not required unless the Grease Cartridge Housing (28) was removed from the Pump Head (11).

Removing Empty Cartridge

1. Loosen the Grease Cartridge Housing (28) a couple of turns from the pump head (11) to allow air to enter the cartridge housing.
2. Pull back on the Follower Handle (30) until the follower rod is fully extended, and latch the follower rod groove into the slot on the tube cap.
3. Unscrew the Grease Cartridge Housing (28) from the Pump Head (11).
4. Carefully release the follower handle to eject the empty cartridge from the container tube.

Disassembly Procedure (See Exploded View and Fig. #3)

Tools Required:

- 11/16" wrench
 - 3/4" wrench
 - 5/16" Allen wrench
1. Loosen the Grease Cartridge Housing (28) a turn or two and pull the Follower Handle (30) until the notch on the follower rod can be latched into the slot in the tube cap.
 2. Remove the Grease Cartridge Housing (28).
 3. Remove the Grease Cartridge is present.
 4. Remove the packing (27) from the pump head (11).
 5. Disconnect the hydraulic supply line from the cylinder block (2).
 6. Loosen each of the four cap screws (1) equally until all tension is removed from the springs (8, 9 & 10) inside the cylinder block (2).
 7. Remove the screws (1) followed by the cylinder block (2).
 8. Remove the piston (4) from the cylinder block (2).
 9. Remove the packing (3) from the piston (4).
 10. Lift the spring retainer (5) until it can be pulled from of the plunger (6).
 11. Remove all the springs (8, 9 & 10) and washer (7) from the pump body (11).
 12. Remove the packing (3) from the pump body (11).
 13. Remove the metering plug (23) and O-Ring (20) from the pump body (11).
 14. Remove the outlet check adapter (19), O-Ring (20), spring (21) and check ball (22) from the pump body (11).
 15. Remove the vent valve (12) or filler fitting (29) from the pump body (11).
 16. Remove the low-level indicator as a unit, (see illus. #3, view D) by removing the bushing from the pump body (11).
 17. Disassemble the low level indicator by removing the indicator cap (18) and lower retaining ring (13) from the indicator rod (14).

**HYDRAULIC HAMMER PUMP
MODEL 85429
Series "B"**



18. Carefully slide the indicator rod (14) from the bushing (17). The spring (16), washer (15) may now be removed from the indicator rod (14).
19. Remove O-ring (25) from the bushing (17).
20. Remove the spring clip (32) and plate (33) from the pump body (11) by removing two screws (35) and lock washer (34).
21. Disassemble the grease cartridge housing (28) by unscrewing the cap counterclockwise from the tube. Slide the rod, spring and packing assembly out of the reservoir tube.
22. Remove the retaining clip (31) from the cap.
23. Compress the spring and remove the follower handle (30) from the rod.
24. Carefully release the spring tension and remove the spring and cap from the follower rod.
25. The follower assembly (26) can be removed from the follower rod by sliding up the rod towards the handle end of the rod.
26. All components should be cleaned. Worn or damaged parts should be replaced. All packings and seals should be replaced.
27. Reassemble in the reverse order of assembly. Use views in illus. #3 for aid in installing packings correctly and in reassembly of the pump. Lincoln recommends using thread locking compound (such as Loctite #242 or equivalent) for all threaded connections during reassembly.
28. When installing the spring clip (32), adjust as required for cartridge or bulk filling. See **Installing Grease Cartridge or Manual (Bulk) Filling** as required for adjustment procedures.
29. When installing the cylinder head (2) the cap screws (1) should be tightened to a torque of 13-14 ft.-lbs.
30. If pump is to be reassembled without filling the grease reservoir, install the grease cartridge housing (28) with the follower rod groove latched into the slot in the tube cap. This will prevent the low level indicator rod (14) from binding with the follower assembly (26).

HYDRAULIC HAMMER PUMP
 MODEL 85429
 Series "B"

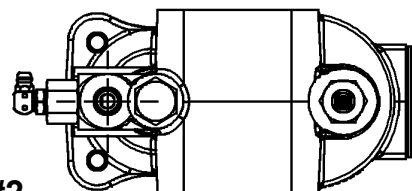
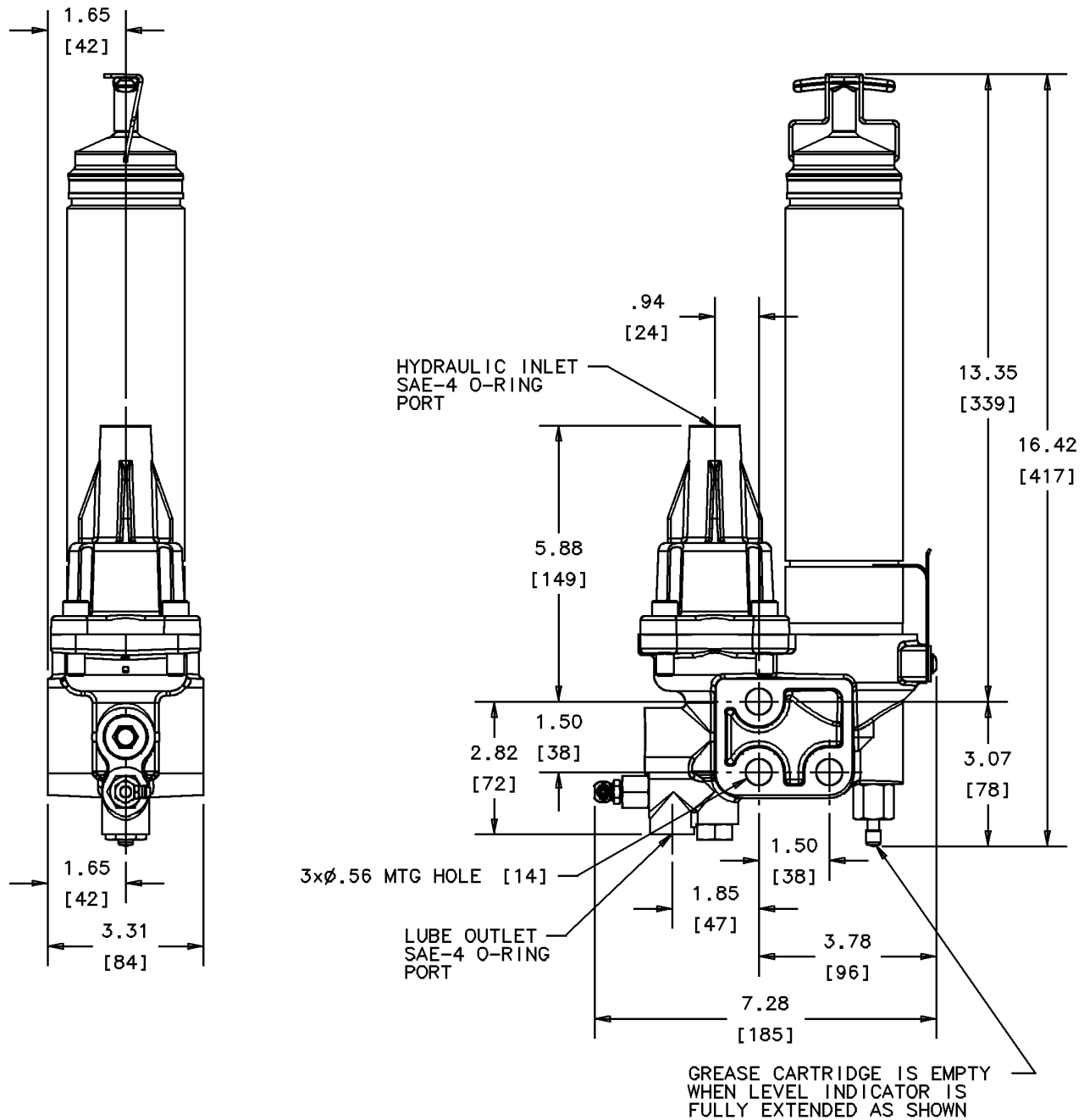
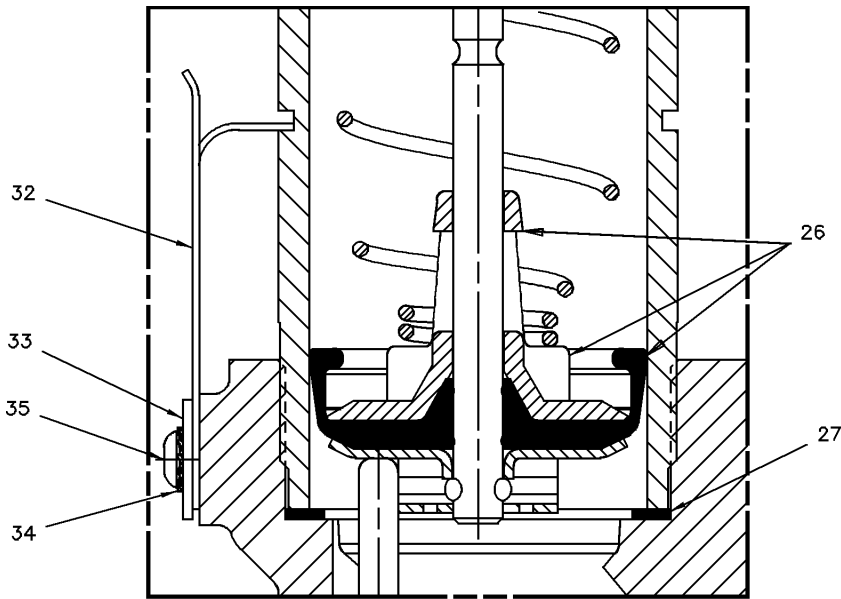
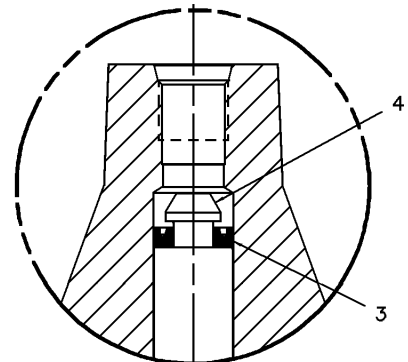

Fig. #2

**HYDRAULIC HAMMER PUMP
MODEL 85429
Series "B"**



View A



View B

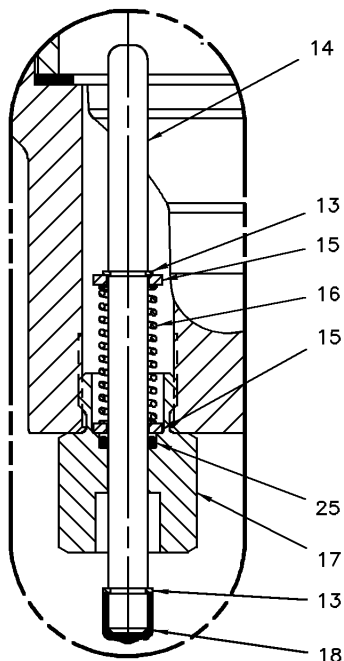

View D

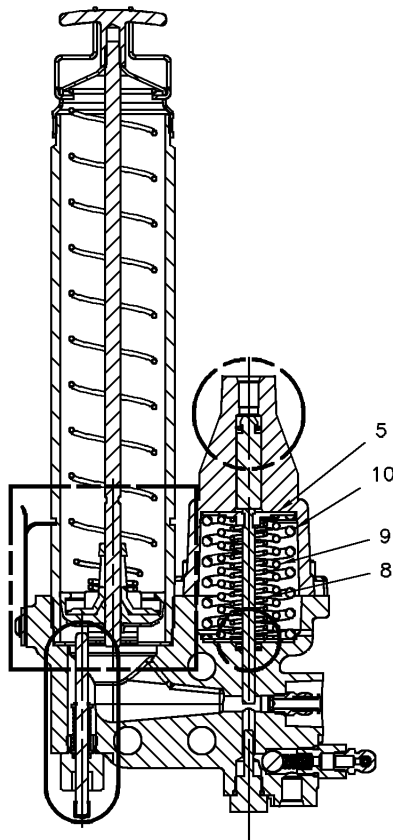
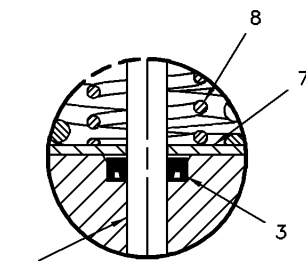

Fig. #3



View C

HYDRAULIC HAMMER PUMP
MODEL 85429
Series "B"

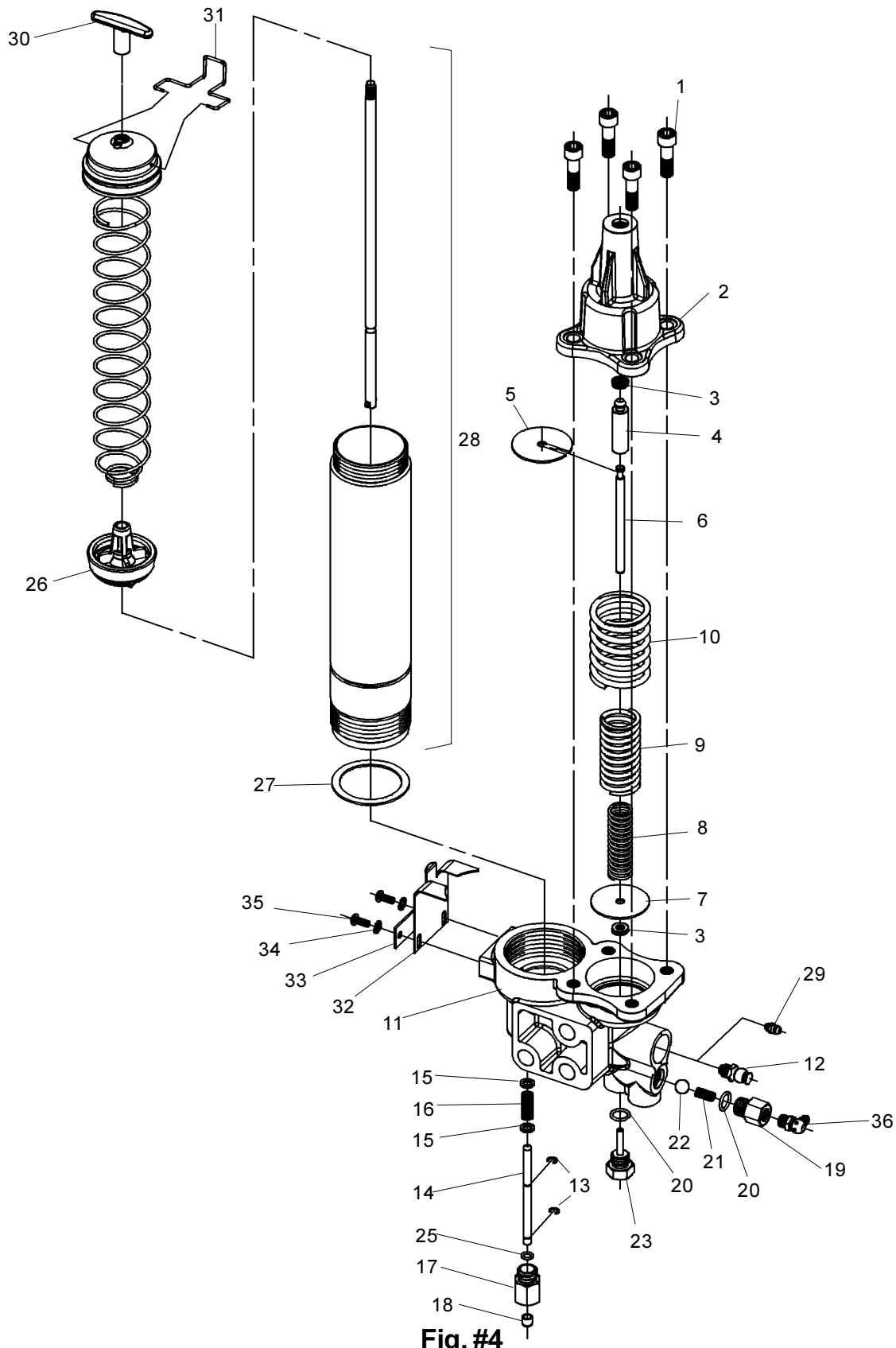

Fig. #4

**HYDRAULIC HAMMER PUMP
MODEL 85429
Series "B"**



REPAIR PARTS LIST

Item No.	Qty.	Description	Repair Part No.
1	4	Socket Head Screw (3/8-16 x 1-1/4")	271923
2	1	Cylinder Block	271935
3	2	U-Cup (polyurethane)	(See Note #1)
4	1	Piston	271921
5	1	Spring Retainer	271931
6	1	Plunger	271922
7	1	Washer	48397
8	1	Spring	249966
9	1	Spring	249965
10	1	Spring	249964
11	1	Pump Head	271933
12	1	Vent Valve	243307
13	1	Retaining Ring	68405
14	1	Indicator Rod	249976
15	2	Washer	48358
16	1	Spring	249967
17	1	Bushing	271929
18	1	Indicator Cap	249969
19	1	Outlet Housing	249957
20	1	O-Ring (Nitrile)	(See Note #1)
21	1	Spring	55005
22	1	Check Ball	66030
23	1	Metering Plug (0.1 cc)	271927
24	1	O-Ring (nitrile)	(See Note #1)
25	1	O-Ring (Nitrile)	(See Note #1)
26	1	Follower Assembly	93485
27	1	Packing (neoprene)	249968
28	1	Grease Cartridge Housing (incl. #26 & 30)	249952
29	1	Fill Fitting (Optional)	5003©
30	1	Follower Handle	261514
31	1	Retaining Clip	272216
32	1	Spring Clip	272257
33	1	Plate	272258
34	2	Lockwasher #10	66213
35	2	#10-32 x 1/2" Button Head Cap Screw	272259
	1	Seal Kit	271936

Notes:

1. Included in 271936 Seal Kit

© Indicates change



TROUBLESHOOTING

Condition	Possible Cause	Corrective Action
Pump does not operate.	No hydraulic pressure to pump.	Turn on or connect hydraulic supply.
	Piston or plunger is stuck.	Disassemble pump, inspect for damaged or worn parts. Replace if necessary.
	Hydraulic Pressure is too high or low for Return Springs installed.	Check hydraulic pressures & select springs from pressure chart.
	Broken Return Spring(s)	Replace all Return Springs.
Pump does not dispense grease.	Grease cartridge is empty.	Replace empty grease cartridge.
	Follower is stuck.	Check Cartridge Housing for damage.
	Worn Plunger or Pump Body.	Replace worn parts.
Lubricant or hydraulic fluid in spring chamber.	Worn seal on plunger or piston.	Disassemble pump, replace worn seals.

**HYDRAULIC HAMMER PUMP
MODEL 85429
Series "B"**



Americas:
One Lincoln Way
St. Louis, MO 63120-1578
USA
Phone +1.314.679.4200
Fax +1.800.424.5359

Europe/Africa:
Heinrich-Hertz-Str 2-8
D-69183 Walldorf
Germany
Phone +49.6227.33.0
Fax +49.6227.33.259

Asia/Pacific:
25 Int'l Business Park
#01-65 German Centre
Singapore 609916
Phone +65.562.7960
Fax +65.562.9967

© Copyright 2001
Printed in USA

Web site:
www.lincolnindustrial.com